

# SECTION 6D

## ENGINE ELECTRICAL

### CONTENTS

GENERAL DESCRIPTION .....	6D-1
BATTERY .....	6D-3
CHARGING SYSTEM .....	6D-9
IGNITION SYSTEM .....	6D-20
CRANKING SYSTEM .....	6D-36

## GENERAL DESCRIPTION

Engine electrical system includes the battery, ignition (primary and secondary), starter (and related wiring) and the generator (and related wiring). The following diagnosis charts will aid in trouble-shooting system faults. When a fault is traced to a particular component, refer to that components section of the service manual.

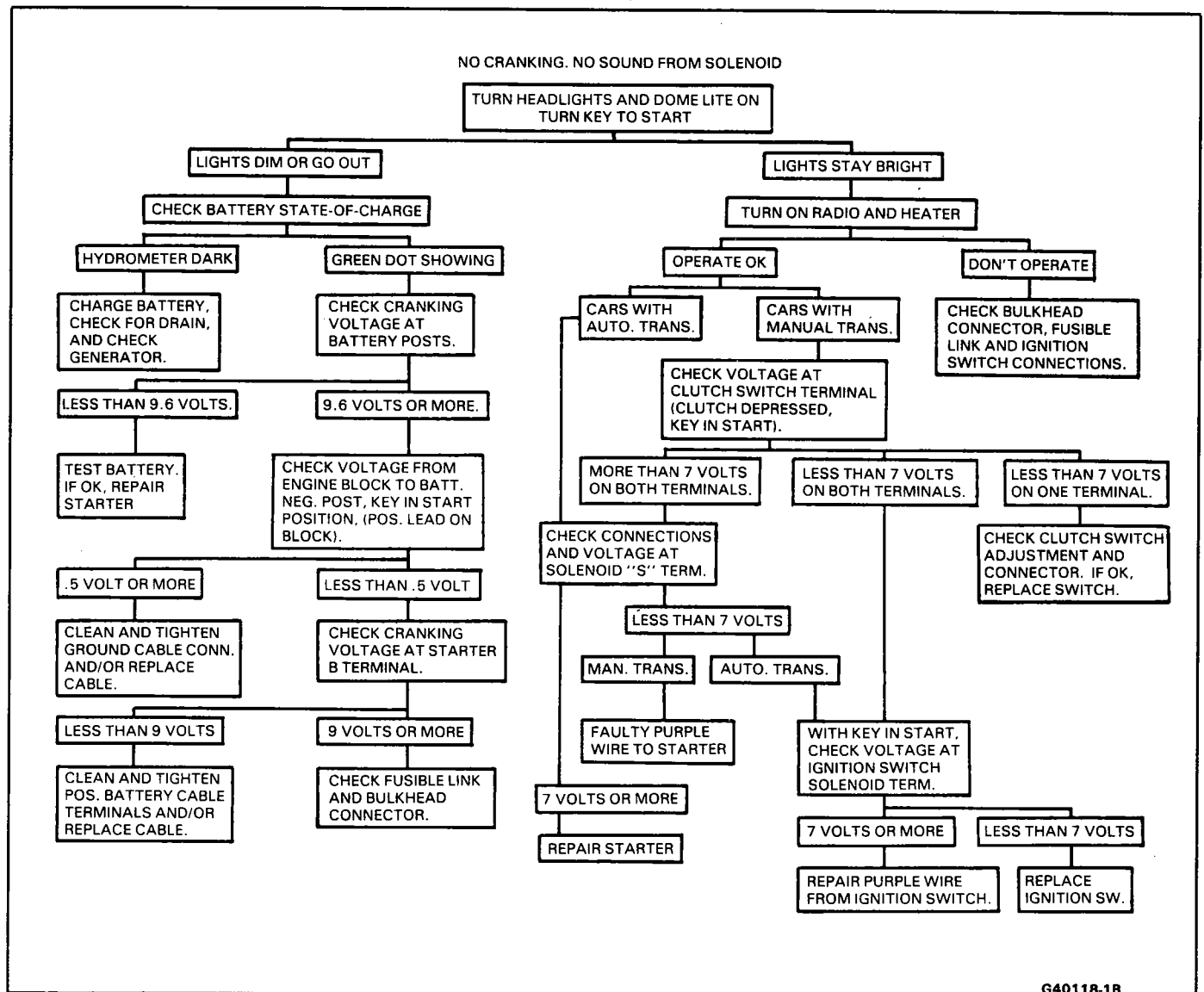

Figure 6D-1 Electrical System General Diagnosis - 1 of 2

**SLOW CRANKING, SOLENOID CLICKS OR CHATTERS**

**CHECK: BATTERY FOR GREEN DOT IN HYDROMETER  
VISUAL CONDITION OF BATTERY CABLES AND CONNECTIONS.  
IF BATTERY NEEDS CHARGING, MAKE GENERATOR AND BATTERY DRAIN  
CHECK, CHARGE BATTERY AND RECHECK CRANKING. IF TROUBLE HAS  
NOT BEEN FOUND, PROCEED.**

**REMOVE BATTERY LEAD FROM DISTRIBUTOR ON HEI. MAKE ALL  
VOLTMETER READINGS WITH KEY IN START POSITION.**

**MEASURE CRANKING VOLTAGE AT BATTERY TERMINAL POSTS.**

**9.6 VOLTS OR MORE**

**LESS THAN 9.6 VOLTS**

**MEASURE VOLTAGE FROM BATTERY  
NEGATIVE TERMINAL TO ENGINE  
BLOCK. (POS. LEAD ON BLOCK.)**

**CHARGE AND  
LOAD TEST BATTERY**

**.5 VOLT OR MORE**

**LESS THAN .5 VOLT**

**OK**

**NOT OK**

**REPAIR GROUND  
CABLE AND  
CONNECTIONS**

**MEASURE VOLTAGE  
AT SOLENOID "B"  
TERMINAL, CLEAN  
AND TIGHTEN  
CONNECTIONS AT  
STARTER.**

**REPAIR  
STARTER**

**REPLACE  
BATTERY**

**9 VOLTS OR MORE**

**LESS THAN 9 VOLTS**

**REPAIR  
STARTER**

**CLEAN AND TIGHTEN POSITIVE CABLE CONNECTIONS.  
IF OK, REPLACE CABLE.**

**THIS PROCEDURE IS DESIGNED FOR USE ON EN-  
GINES AND BATTERIES AT ROOM OR NORMAL  
OPERATING TEMPERATURES. IT ALSO ASSUMES  
THERE ARE NO ENGINE PROBLEMS WHICH  
WOULD CAUSE A NO START CONDITION. TO USE  
IT UNDER OTHER CONDITIONS MIGHT RESULT IN  
MISDIAGNOSIS.**

# BATTERY

## CONTENTS

General Description .....	6D-3	Charging Procedure .....	6D-5
Battery Rating .....	6D-3	Charging Time Required .....	6D-6
Battery Label .....	6D-3	Charging A Very Low Battery .....	6D-6
Built-In Hydrometer .....	6D-4	Jump Starting .....	6D-6
Battery Retainer .....	6D-4	Battery Replacement .....	6D-7
Diagnosis .....	6D-4	Battery Cable Replacement .....	6D-7
Electrolyte Freezing Load Test .....	6D-5	Ground Straps .....	6D-7
On-Car Service .....	6D-5	Battery Chart .....	6D-8
Battery Charging .....	6D-5		

The sealed battery (see Figure 6D-3) is standard on all cars. (See Specifications at the end of this section for specific applications.) The battery is completely sealed, except for two small vent holes in the sides, that allow small amount of gas produced in the battery to escape. Do not exceed 45° angle when carrying or installing the battery as a small amount of electrolyte may leak out of the vent holes. The battery has the following advantages over conventional batteries:

1. No water addition for the life of the battery.
2. Overcharge protection. If too much voltage is applied to the battery, it will not accept as much current as a conventional battery. In a conventional battery, the excess voltage will still try to charge the battery, leading to gassing which causes liquid loss.
3. Not as liable to self-discharge as compared to a conventional battery. This is particularly important when a battery is left standing for long periods of time.
4. More power available in a lighter and smaller case.

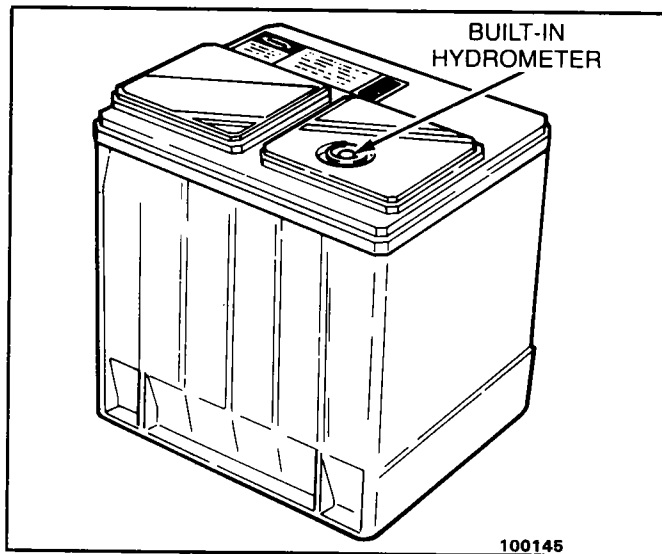

Figure 6D-3 Sealed Top Battery

The battery has three major functions in the electrical system: First, it provides a source of energy for cranking the engine; Second, it acts as a voltage stabilizer for the electrical system; And third, it can, for a limited time, provide energy when the electrical load used exceeds the output of the generator.

### Battery Ratings

A Battery has two ratings that indicate the relative amount of strength that the battery holds. One is cold

cranking amps and the other is reserve capacity that is measured in minutes. (See Figure 6D-10.)

The Cold Cranking Amps is a rating that is required for an individual application to crank the engine for 30 seconds at a specific temperature. It is an indication of the plate area in a battery. As the number of plates per cell is increased, the cold cranking ampere capacity is also increased. Although the plates are thinner, the greater number of plates expose more plate area to the electrolyte, resulting in a higher capacity.

Reserve Capacity is measured in minutes and is an indication on how long the car can travel at night with minimum electrical load and no generator output. It is the time required for a fully charged battery, at a temperature of 80°F being discharged of a constant current of 25 amperes to reach a terminal voltage of 10.5 volts.

Some of the things that will affect the reserve capacity time are:

- State of charge of battery (age and condition)
- Temperature
- A/C or other electrical options
- Vehicle load (passengers, luggage, trailer, etc.)
- Terrain

### Battery Label

The battery label contains information important to the servicing of the battery (Figure 6D-4). This information includes: test ratings and both o.e. (original equipment) and recommended replacement part numbers. This information is also included in the battery usage charts at the end of this section.

Whenever replacing a battery, always replace it with one that meets the same specifications as the one that was removed.

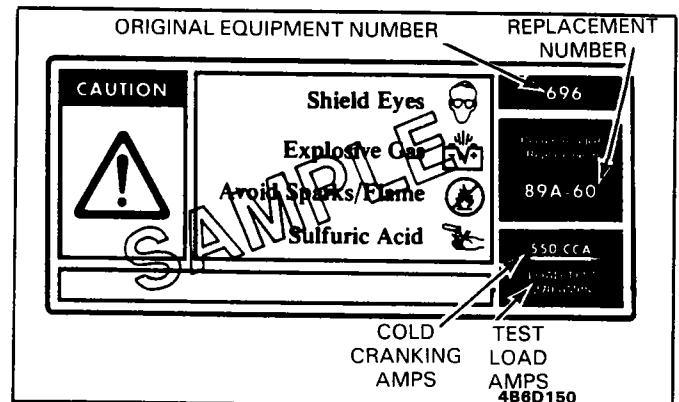

Figure 6D-4 Battery Label

### Built-In Hydrometer

The sealed battery has a built-in temperature compensated hydrometer in the top of the battery. (See Figure 6D-5.) This hydrometer is to be used with the following diagnostic procedure.

When observing the hydrometer, make sure that the battery has a clean top. A light may be required if the battery being checked is in an area where the lighting is poor.

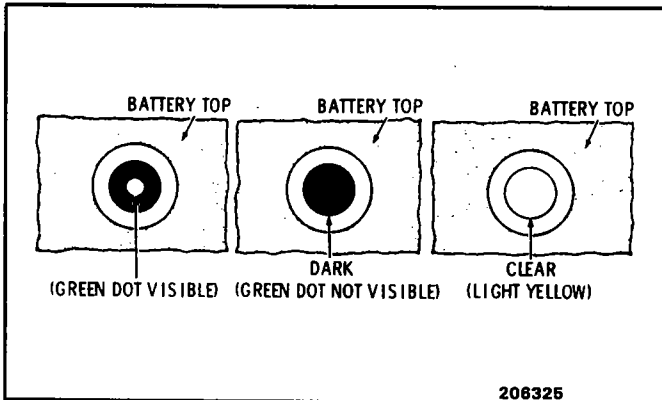

Figure 6D-5 Build-In Hydrometer

The lower retainer fits into the slot that is built into the lower part of the battery. A retainer and bolt hold the retainer to the battery carrier. (See Figure 6D-7.)

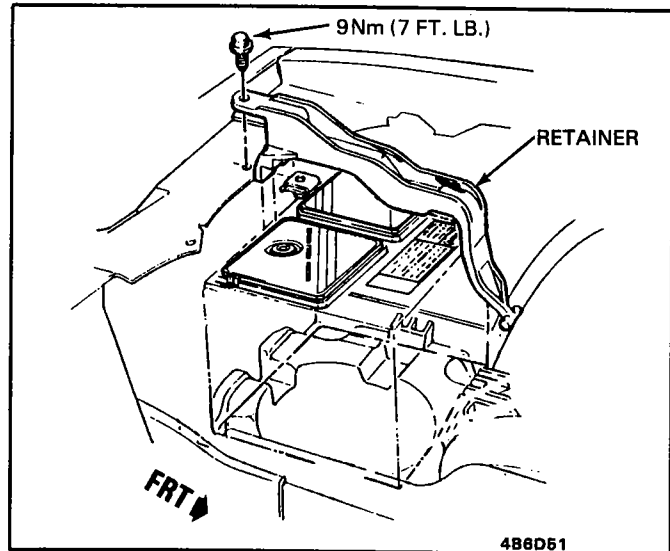

Figure 6D-6 Battery Upper Retainer

Under normal operation, three indications can be observed:

1. **GREEN DOT VISIBLE**

The appearance of the green dot indicates that the battery is ready for testing.

2. **DARK; GREEN DOT NOT VISIBLE**

If there is a cranking complaint, the battery should be tested as described in the Diagnosis section. The charging and electrical system should also be checked at this time. Tap side of battery with your hand to ensure green hydrometer ball is free floating in hydrometer cage.

3. **CLEAR OR LIGHT YELLOW**

This means the fluid level is below the bottom of the hydrometer. This may have been caused by excessive or prolonged charging, a broken case, excessive tipping or normal battery wearout. When finding a battery in this condition it may indicate high charging voltages caused by a faulty charging system and therefore the charging and electrical systems may need to be checked. If a cranking complaint exists and is caused by the battery, it should be replaced. Do not attempt to charge the battery when the Hydrometer shows clear or light yellow.

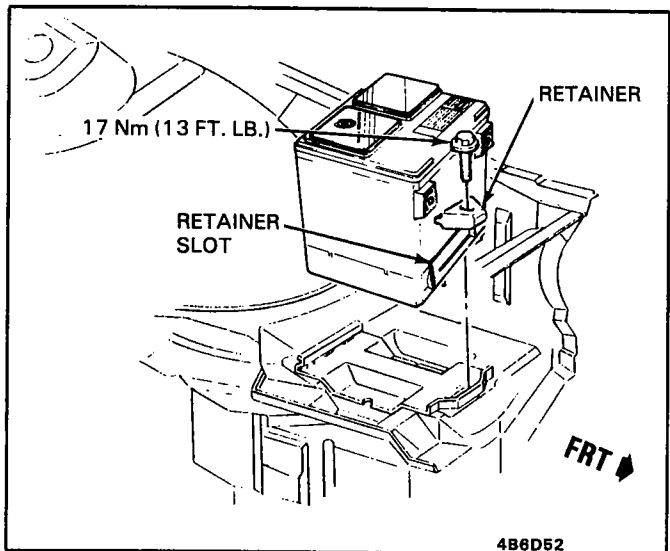

Figure 6D-7 Battery Lower Retainer

### Battery Retainer

The battery retainer is an important part, because if it is not tightened properly or if it is not reinstalled, the life of the battery will be shortened. A loose battery will bounce around in the battery tray creating internal damage. Make certain there are no parts in the carrier before installing battery. Then install the battery making sure it fits properly into the carrier and is level. Then install the retainer and tighten the retainer bolt. There are two types of retainers used:

1. **Upper Retainer.**

This type of retainer goes over the top of the battery and applies downward pressure on the battery. (See Figure 6D-6.)

2. **Lower Retainer.**

## DIAGNOSIS

The following procedure should be used for testing batteries:

1. **VISUAL INSPECTION**

Check for obvious damage, such as cracked or broken case or cover, that could permit loss of electrolyte. If obvious damage is noted, replace the battery. Determine cause of damage and correct as needed. If not, proceed to step 2.

2. **HYDROMETER CHECK (Figure 6D-5)**

a. **GREEN DOT VISIBLE** - Go to Load Testing

b. **DARK; GREEN DOT NOT VISIBLE**

Charge the battery as outlined under "Charging Procedure" section and proceed to Step 3.

c. **CLEAR OR LIGHT YELLOW**

If a cranking complaint exists and is caused by the battery, it should be replaced. Do not attempt to charge the battery when the Hydrometer shows clear or light yellow. (See Specifications for specific battery ratings.)

## Battery State Of Charge

The state of charge of a battery is very important in starting the engine. At a temperature of about 80°F a fully charged battery will provide 100% of its capacity, while the engine cranking load is also at 100% of its requirement as shown in Figure 6D-8.

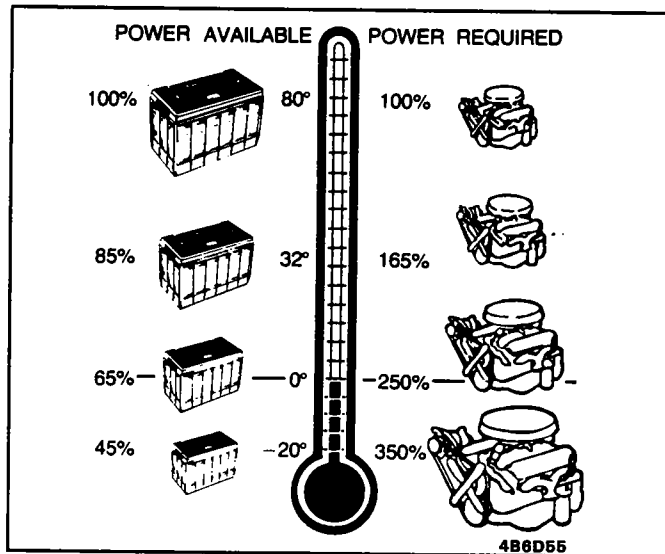

Figure 6D-8 Battery Power and Load Requirements

As the temperature begins to get lower, the available power from the battery decreases while the cranking load demand becomes higher.

At temperatures below 0°F, the power available from a good, fully charged battery can be below 50% while at the same time the power requirement for cranking the engine can be over 300%.

Difficulty in cranking the engine can also be encountered during hot weather operation if the battery does not maintain a full charge. This will occur because a hot engine can impose as high a cranking load as an engine during cold weather operation.

Insufficient state of charge and poor electrical contacts at the cable ends are two of the prime factors when there is a no starter engagement problem.

If the battery tests good but fails to perform satisfactorily in service for no apparent reason, the following are some of the more important factors that may point to the cause of trouble:

1. Vehicle accessories left on overnight.
2. Slow average driving speeds for short periods with accessories on.
3. The cars electrical load is more than the generator output, particularly with the addition of after market equipment.
4. Problems in the charging system such as electrical shorts, slipping fan belt, faulty generator, or voltage regulator.
5. Battery abuse, including failure to keep the battery cable terminals clean and tight, or loose battery hold-down. See On-Car Service for torque specifications.
6. Problems in the electrical system, such as shorted or open pinched wires.

## Electrolyte Freezing

The freezing point of electrolyte depends on its specific gravity. Since freezing may ruin a battery, it should be protected against freezing by keeping it in a charged condition.

## Load Test

Load testing may require use of battery side terminal adapters to insure good connections (see Figure 6D-9). On diesel engine cars, disconnect and test each battery separately.

- a. Connect a voltmeter and a battery load tester across the battery terminals.

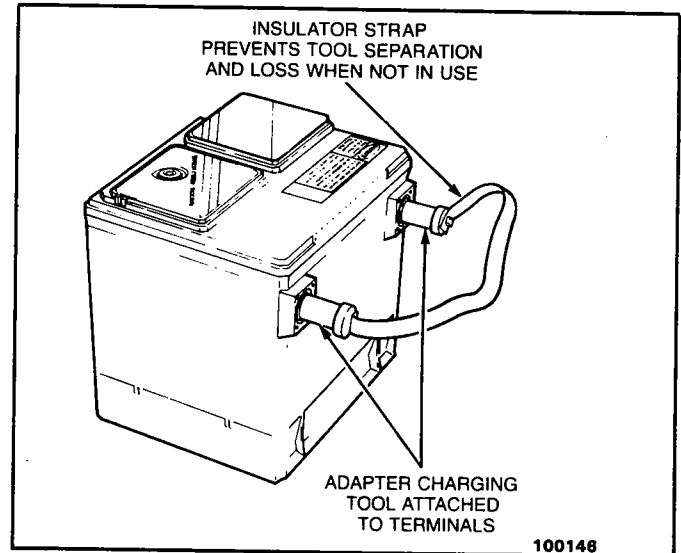

Figure 6D-9 Side Terminal Battery Adapters

- b. Apply 300 ampere load for 15 seconds to remove surface charge from the battery. Remove load.
- c. Wait 15 seconds to let battery recover and apply specified load from Figure 6D-10. Read voltage after 15 seconds, then remove load.
- d. The voltage at room temperature should be above 9.4 volts. If the battery has been exposed to temperatures below freezing, the voltage should be above 8.5 volts. A cold battery that maintains at least 8.5 volts or a room temperature battery that maintains at least 9.4 volts are considered good batteries and should be returned to service.

## ON CAR SERVICE

### BATTERY CHARGING

When it is necessary to charge the battery, the following basic rules must be followed:

1. Do not charge battery if it seems to be frozen.
2. Do not charge battery if hydrometer is clear or light yellow. Replace battery.
3. If the battery feels hot 52°C (125°F), or if violent gassing or spewing of electrolyte through the vent holes occurs, discontinue charging or reduce charging rate.

### Charging Procedure

1. Batteries with green dot showing do not require charging unless they have just been discharged (such as in cranking vehicle).

2. When charging sealed-terminal batteries out of vehicle, install side terminal adapter kit (AC Delco part number ST-1201 or GM part number 1846855 or equivalent). (Refer to Figure 6D-9.)
3. Make sure all charger connections are clean and tight.
4. For best results, batteries should be charged while electrolyte and plates are at room temperature. A battery that is extremely cold may not accept current for several hours after starting charger.
5. Charge battery until green dot appears (see Charging Time Required). Battery should be checked every half-hour while charging. Tipping or shaking battery may be necessary to make green dot appear.
6. After charging, battery should be tested as outlined in BATTERY TESTING.

### Charging Time Required:

The time required to charge a battery will vary dependent upon the following factors:

- **Size of Battery** - A completely discharged large heavy-duty battery requires more than twice the recharging as a completely discharged small passenger car battery.
- **Temperature** - A longer time will be needed to charge any battery at 0°F than at 80°F. When a fast charger is connected to a cold battery, the current accepted by the battery will be very low at first, then in time the battery will accept a higher rate as the battery warms.
- **Charger Capacity** - A charger which can supply only five amperes will require a much longer period of charging than a charger that can supply 30 amperes or more.
- **State-Of-Charge** - A completely discharged battery requires more than twice as much charge as a one-half charged battery. Because the electrolyte is nearly pure water and a poor conductor in a completely discharged battery, the current accepted by the battery is very low at first. Later, as the charging current causes the electrolyte acid content to increase, the charging current will likewise increase.

### CHARGING A VERY LOW OR COMPLETELY DISCHARGED BATTERY (OFF THE VEHICLE)

The following procedure should be used to recharge a very flat or completely discharged battery:

Unless the procedure is properly followed, a perfectly good battery may be needlessly replaced.

1. Measure voltage at battery terminals with an accurate voltmeter. If below 10 volts, then the charge current will be very low and it could take some time before it accepts a current in excess of a few milliamperes. Such low current may not be detectable on ammeters available in the field.
2. Set battery charger on high setting.
3. Some chargers feature polarity protection circuitry which prevents charging unless the charger leads are connected to the battery terminals correctly. A completely discharged battery may not have enough voltage to activate this circuitry, even though leads are connected properly, making it appear that the battery will not accept charging current. Therefore, follow the specific charger manufacturer's instruction telling how to bypass or override the circuitry so that the charger will turn on and charge a low-voltage battery.
4. Battery chargers vary in the amount of voltage and current they provide. The time required for the battery

to accept measurable charger current at various voltages may be as follows:

VOLTAGE	HOURS
A. 16.0 or more	Up to 4 Hours
B. 14.0 - 15.9	Up to 8 Hours
C. 13.9 or less	Up to 16 Hours

**If the charge current is still not measurable** at the end of the above charging times, the battery should be replaced.

**If the charge current is measurable** during the charging time, the battery is considered to be good and charging should be completed in the normal manner.

5. It is important to remember that a completely discharged battery must be recharged for a sufficient number of ampere hours (AH) to restore it to a usable state. As a general rule of thumb, using the reserve capacity rating (RC) of the battery as the number of ampere hours of charge will usually bring the green dot into view.

For example, if battery is rated at 75 RC minutes, it would be completely recharged as follows:

$$10 \text{ ampere charge} \times 7\text{-}1/2 \text{ hours} = 75 \text{ AH}$$

or

$$25 \text{ ampere charge} \times 3 \text{ hours} = 75 \text{ AH, etc.}$$

6. It is recommended that any battery recharged by this procedure be **LOAD TESTED** to establish serviceability.

### JUMP STARTING IN CASE OF EMERGENCY WITH AUXILIARY (BOOSTER) BATTERY

**NOTICE:** Do not push or tow the vehicle to start. Damage to the emission system and/or to other parts of the vehicle may result.

Both booster and discharged battery should be treated carefully when using jumper cables. Follow the procedure outlined below, being careful not to cause sparks:

**CAUTION:** Departure from these conditions or the procedure below could result in: (1) Serious personal injury (particularly to eyes) or property damage from such causes as battery explosion, battery acid, or electrical burns; and/or (2) damage to electronic components of either vehicle.

Never expose battery to open flame or electric spark. Batteries generate a gas which is flammable and explosive.

Remove rings, watches, and other jewelry. Wear approved eye protection.

Do not allow battery fluid to contact eyes, skin, fabrics, or painted surfaces - fluid is a corrosive acid. Flush any contacted area with water immediately and thoroughly. Be careful that metal tools or jumper cables do not contact the positive battery terminal (or metal in contact with it) and any other metal on the car, because a short circuit could occur. Batteries should always be kept out of the reach of children.

1. Set parking brake and place automatic transmission in PARK (NEUTRAL for manual transmission.) **Turn off the ignition, turn off lights, and all other electrical loads.**
2. Check the built-in hydrometer. If it is clear or light yellow, replace the battery. Do not put battery on charger.
3. Attach the end of one jumper cable to the positive terminal of the booster battery and the other end of the same cable to the positive terminal of the discharged battery. Do not permit vehicles to touch each other as

this could cause a ground connection and counteract the benefits of this procedure. (Use 12-volt battery only to jump start the engine).

4. Attach one end of the remaining negative cable to the negative terminal of the booster battery, and the other end to a solid engine ground (such as A/C compressor bracket or generator mounting bracket) at least 18 inches from the battery of the vehicle being started (DO NOT CONNECT DIRECTLY TO THE NEGATIVE TERMINAL OF THE DISCHARGED BATTERY).
5. Start the engine of the vehicle that is providing the jump start and turn off electrical accessories. Then start the engine in the car with the discharged battery.
6. Reverse these directions exactly when removing the jumper cables. The negative cable must be disconnected from the engine that was jump started first.

### Battery Replacement

1. Disconnect negative cable.
2. Disconnect positive cable.
3. Remove retainer screw and retainer.
4. Remove battery.
5. To install, reverse removal procedure.
6. Torque battery cables to 12 N·m (9 lb. ft.).

### Battery Cable Replacement

Whenever battery cables are replaced, always be certain to use a replacement cable that is the same type and length. Some positive cables have additional feed wires attached to them and some negative cables have additional ground leads attached.

Always be certain when replacing a battery cable to route it the same as the one being replaced.

When replacing a battery cable, always observe the routing of the old cable, so that the new one will be positioned in the same location as the old one.

### Battery Cables (OHC Engine)

Although the battery used with the 1.8L OHC engine is the same as used with the 1.8L standard mounting camshaft engine, the battery cables are different. Since the starter is mounted on the right-hand side of the engine, a specific positive battery cable is used. The ground cable for a vehicle equipped with automatic transmission is longer than the ground cable on vehicles equipped with manual transmission.

### Ground Straps

Additional ground straps are used to connect the body and frame to the engine and transmission. Always connect all ground straps to ensure a good ground path to the battery from all electrical components.

**6D-8 ENGINE ELECTRICAL**

<b>SERIES</b>	<b>ENGINE CODE</b>	<b>STANDARD</b>	<b>HIGH CAPACITY</b>
A	LR8 R	1981601	1981730
	LG3 3	1981601	N/A
	LB6 W	1981729	1981730
B	LV2 Y	1981729	1981733
C-H	LG3 3	1981601	1981735
E	LG3 3	1981734	1981735
G	LV2 Y	1981729	1981730
	LC2 7	1981730	1981601
	LD5 A	1981730	1981601
J	LT2 K	1981601	N/A
	LT3 M	1981601	N/A
	LL8 1 (AUTO TRAN)	1981601	N/A
	LL8 1 (MAN TRAN)	1981730	1981601
N	LN7 L	1981601	N/A
	LR8 R	1981601	N/A

<b>BATTERY</b>	<b>COLD CRANKING AMPS-0°F</b>	<b>RESERVE CAPACITY MINUTES</b>	<b>LOAD TEST AMPS</b>
1981600	525	75	260
1981601	630	90	310
1981729	730	90	210
1981730	525	90	260
1981731	570	90	280
1981733	540	115	270
1981734	630	115	310
1981735	730	115	360
1981736	770	115	380

Figure 6D-10 Battery Chart



# CHARGING SYSTEM

## CONTENTS

Introduction .....	6D-9	SI Type Generator .....	6D-10
CS Type Generator .....	6D-9	General Description .....	6D-10
General Description .....	6D-9	Diagnosis .....	6D-10
Diagnosis .....	6D-9	On-Car Service .....	6D-10
On-Car Service .....	6D-10	Disassembly, Text and Reassembly-SI .....	6D-17
Disassembly, Text and Reassembly-CS .....	6D-11		

## INTRODUCTION

Two types of generators are currently in use, the CS and the SI type. The CS generator uses a four terminal connector and the SI uses a two terminal connector.

The CS type generator will be covered first and then the SI. The generator chart and mounting illustrations are at the end of the section.

**NOTICE:** Always disconnect negative battery cable any time the generator is serviced. Always maintain correct battery polarity. Incorrect positive and negative hook-up will cause damage to the system.

## CS TYPE GENERATOR

### GENERAL DESCRIPTION

There are three types of CS generators:

- CS 121
- CS 130
- CS 144

Only the CS 144 can be disassembled and serviced. The CS 121 and CS 130 are replaced when they become inoperative.

The CS type generator uses a new type regular which has build-in fault detection monitored by the ECM. It does not have a diode trio or test hole.

The delta stator, rectifier bridge, and rotor with slip rings and brushes are electrically similar to earlier generators. A conventional pulley and fan is used to cool the slip ring end frame, rectifier bridge and regulator.

Unlike three-wire generators, this generator may be used with only two connections - battery positive and an "L" terminal to the charge indicator light. Use of "P," "F," and "S" terminals is optional. The "P" terminal is connected to the stator and may be connected externally to a tachometer or other device. The "F" terminal is connected internally to field positive and is used in service diagnostics. The "S" terminal may be connected externally to a voltage, such as battery voltage, to sense voltage to be controlled.

As on other charging systems, the charge indicator illuminates when the switch is closed and goes out when the engine is running. If the charge indicator is illuminated with the engine running, a charging system defect is indicated. The indicator will glow at full brilliance for all defects. Also, the charge indicator will be on with the engine running if system voltage is too high or too low.

The regulator voltage setting varies with temperature and limits system voltage by controlling rotor field current. This regulator switches rotor field current on and off at a fixed frequency of about 400 cycles per second. By varying the on-off time, correct average field current for proper system voltage control is obtained. At high speeds, the on-time may be 10% and the off-time is 90%. At low speeds, with high electrical loads, on-off time may be 90% and 10%, respectively.

No periodic maintenance on the generator is required.

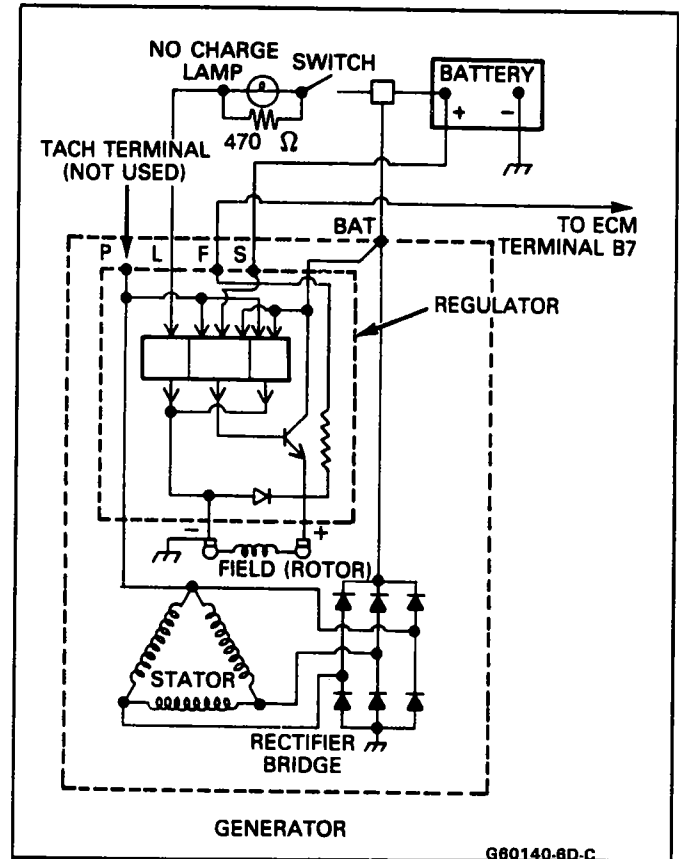

Figure 6D-11 CS Charging Circuit

## DIAGNOSIS

A basic wiring diagram for the charging system (CS) is shown in Figure 6D-11. When operating normally, the indicator lamp will come on when the ignition switch is turned on and go out when the engine starts. If the lamp operates abnormally, or if an undercharged or overcharged battery condition occurs, the following procedure may be used to diagnose the charging system. Remember that an undercharged battery is often caused by accessories being left on overnight, or by a faulty switch which allows a lamp, such as a trunk or glove box lamp, to stay on. Also, this generator does not have a test hole.

To diagnose the CS-121, CS-130 and CS-144 charging systems, use the following procedure:

1. Visually check belt and wiring.
2. For cars without charge indicator lamp, go to step 5.
3. With ignition switch "On," engine stopped, lamp should be on. If not, detach harness at generator and ground "L" terminal.
  - a. Lamp lights, repair or replace the generator.

- b. Lamp does not light, locate open circuit between grounding lead and ignition switch. Lamp may be open.
- 4. With ignition switch "On," engine running at moderate speed, lamp should be off. If not, detach wiring harness at generator.
  - a. If lamp goes off, replace or repair generator.
  - b. If lamp stays on, check for grounded "L" terminal wire in harness.
- 5. Battery undercharged or overcharged.
  - a. Detach wiring harness connector from generator.
  - b. With ignition switch "On," engine not running, connect voltmeter from ground to "L" terminal.
  - c. Zero reading indicates open circuit between terminal and battery. Correct as required.
  - d. Reconnect harness connector to generator, run engine at moderate speed.
  - e. Measure voltage across battery. If above 16V, replace or repair generator.
  - f. Turn on accessories, load battery with carbon pile to obtain maximum amperage. Maintain voltage at 13V or below.
    - If within 15 amperes of rated output, generator is OK.
    - If not within 15 amperes or rated output, repair or replace the generator.

CS 144 disassembly, test and reassembly - see Figures 6D-19 and 6D-20.

## ON-CAR SERVICE

The generator does not require periodic lubrication. The rotor shaft is mounted on ball bearings at both ends and each contains a permanent grease supply. At periodic intervals, check mounting bolts for tightness and belt tension adjustment.

- When adjusting belt tension, apply pressure at center of generator, never against either edge frame.

## SI TYPE GENERATOR

### GENERAL DESCRIPTION

The SI generators are of the diode-rectified type, utilizing an integral regulator charging system.

The brown field wire to the generator is used to turn on the generator. The 10 ohm resistance, provided by either the charge light (volts light on some series) or heater relay with optional voltmeter, is needed to protect the diode trio.

Although several models of generators are available with different outputs at idle and different maximum outputs, their basic operating principles are the same.

The generator uses a solid state regulator that is mounted inside the generator. All regulator components are enclosed into a solid mold, and this unit along with the brush holder assembly is attached to the slip ring end frame. The regulator voltage cannot be adjusted.

The generator rotor bearings contain enough grease to eliminate the need for periodic lubrication. Two brushes carry current through the two slip rings to the field coil mounted on the rotor, and under normal conditions will provide long periods of attention-free service.

The stator windings are assembled on the inside of a laminated core that forms part of the generator frame. A rectifier bridge connected to the stator windings contains six diodes and electrically changes the stator a.c. voltages to a d.c. voltage which appears at the generator output terminal. Generator field current is supplied through a diode trio which also is connected to the stator windings. A capacitor,

or condenser, mounted in the end frame protects the rectifier bridge and diode trio from high voltages, and suppresses radio noise.

No periodic adjustments or maintenance of any kind are required on the entire generator assembly.

## DIAGNOSIS

Noise from a generator may be caused by a loose drive pulley, loose mounting bolts, worn or dirty bearings, diode or an inoperative diode or stator.

A basic wiring diagram showing lead connections is shown in Section 8A. A diagram showing the regulator in charging circuit is shown in Figure 6D-11.

To avoid damage to the electrical equipment, always observe the following precautions:

- Do not reverse connections to the generator.
- Do not short across or ground any of the terminals in the charging circuit except as directed by the instructions.
- NEVER operate the generator with the output terminal disconnected.
- When connecting a charger or a booster battery to the car battery, see Battery Charging Section.
- In some cars, a voltmeter may be used instead of an indicator lamp. In this case, Section "A" pertaining to faulty indicator lamp operation should be omitted from the troubleshooting procedure.

Trouble in the charging system will show up as one or more of the following conditions:

- A. Faulty indicator lamp operation.
- B. An undercharged battery as evidenced by slow cranking or hydrometer dark.
- C. An overcharged battery as evidenced by excessive spewing of electrolyte from the vents.

### A. Faulty Charge Light (Volts)

Check the charge light for normal operation as shown in Figure 6D-13.

If the indicator lamp operates normally, proceed to "Undercharged Battery" section. Otherwise, proceed to **one** of the following three **abnormal** conditions:

1. **Switch Off, Lamp On** - Unplug the connector from the generator No. 1 and No. 2 terminals. If the lamp stays on, there is a short between these two leads. If the lamp goes out, replace the rectifier bridge as covered in the "GENERATOR REPAIR" section. This condition will cause an undercharged battery.
2. **Switch On, Lamp Off, Engine Stopped** - This condition can be caused by the problem listed in Part 1 above, or by an open in the circuit. To determine where an open exists, proceed as follows:
  - a. Check for a blown fuse, a burned out bulb, inoperative bulb socket, or an open in No. 1 lead circuit between generator and ignition switch.
  - b. If no problems have been found, proceed to "Undercharged Battery" section.
3. **Switch On, Lamp On, Engine Running** - Check for a blown fuse (where used) between indicator lamp and switch, and also in A/C circuit. The other possible causes of this condition are covered in the "UNDERCHARGED BATTERY" section.

If a problem has been found and corrected at this point, no further checks need be made.

### B. Undercharged Battery

This condition, as shown by slow cranking or hydrometer dark, can be caused by one or more of the

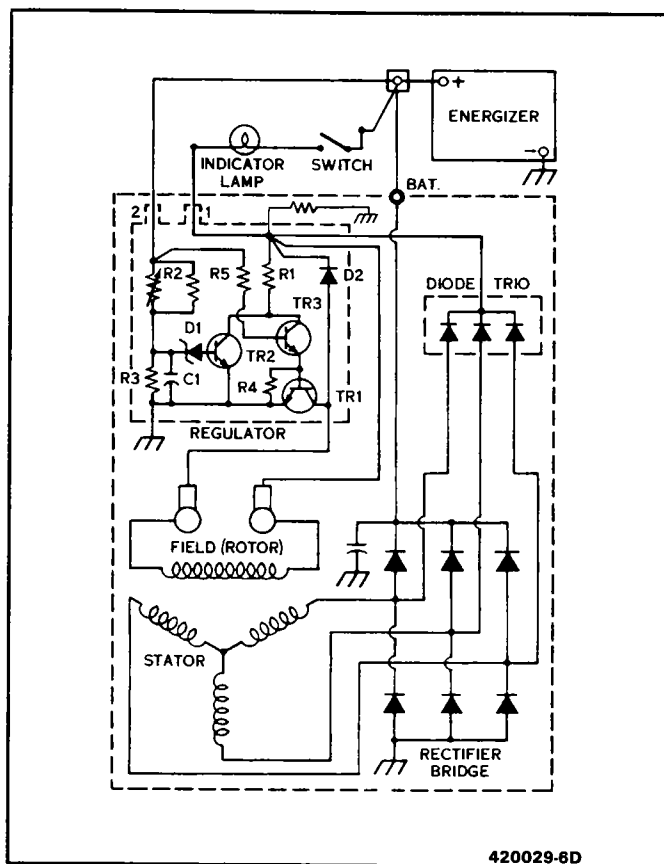

Figure 6D-12 Regulator in Charging Circuit

following conditions even though the indicator lamp may be operating normally. This procedure also applies to cars with a voltmeter.

1. Insure that the undercharged condition has not been caused by accessories having been left on for extended periods.
2. Check the drive belt for proper tension.
3. If a battery problem is suspected, refer to Battery Section.
4. Inspect the wiring for problems. Check all connections for tightness and cleanliness, including the slip connectors at the generator and cowl, and the battery cable connections at the battery, the starter and the engine ground.
5. With ignition switch on and all wiring harness leads connected, connect a voltmeter from:
  - a. Generator "BAT" terminal to ground
  - b. Generator No. 1 terminal to ground
  - c. Generator No. 2 terminal to ground

A zero reading indicates an open between voltmeter connection and battery. Generators have a built-in feature which avoids overcharge and accessory damage by preventing the generator from turning on if there is an **open** in the wiring harness connected to the No. 2 (sensing) generator terminal.
6. If Steps 1 through 5 check satisfactorily, check generator as follows:

- a. Disconnect negative battery cable.
- b. Connect an ammeter or generator tester in the circuit at the "BAT" terminal of the generator.
- c. Reconnect negative battery cable.
- d. Turn on radio, windshield wipers, lights on high beam and blower motor on high speed. Connect a carbon pile across the battery.

- e. Operate engine at about 2000 RPM, and adjust carbon pile as required, to obtain maximum current output.
- f. If ampere output is within 10 amperes of rated output as stamped on generator frame, generator is not defective; recheck Steps 1 through 5.
- g. If ampere output is not within 10 amperes of rated output, determine if test hole (Figure 6D-14) is accessible. If accessible go to Step h. If not accessible go to step l.
- h. Ground the field winding by inserting a screwdriver into the test hole (Figure 6D-14). Make sure tab is within 19mm (3/4 inch) of casting surface. Do not force screwdriver deeper than one inch into end frame.
- i. Operate engine at about 2000 RPM, and adjust carbon pile as required to obtain maximum current output.
- j. If output is within 10 amperes of rated output, check field winding as covered in "UNIT REPAIR" section, and test regulator with an approved regulator tester.
- k. If output is not within 10 amperes of rated output, check the field winding, diode trio, rectifier bridge, and stator as covered in "GENERATOR REPAIR" section.
- l. If test hole is not accessible, disassemble generator and make tests listed in "OVERHAUL" section.

### C. Overcharged Battery

1. To determine battery condition, refer to Battery Section of Section 6D.
  2. If an obvious overcharge condition exists as evidenced by excessive spewing of electrolyte, proceed to "Disassembly" section of "GENERATOR OVERHAUL," and check field winding for grounds and shorts. If damaged, replace rotor and test regulator with an approved regulator tester.
- Generator Tester - Many testers are available to check the generator. They provide a quick on-car test, and can save time over conventional diagnostic methods. Consult manufacturer's instructions for usage.

### Generator Diagnostic Tester Indications

#### Tool J-26290

This tester is designed as a quick check to determine if the generator should be removed from the car. It will indicate about 98% of charging system faults.

**BE CERTAIN ENGINE IS AT FAST IDLE WHEN USING TESTER IN PART 2.**

Connect tester as shown in Figure 6D-15.

1. **Engine Off:** (Lights and Accessories Off)
  - a. Light flashes--Skip steps b and c and go to Part 2.
  - b. Light on--Indicates fault in tester which should be replaced.
  - c. Light off--Pull plug from generator:
    - (1) Flashing light--indicates that the generator should be removed and the rectifier bridge replaced.
    - (2) Light off--indicates faulty tester or no voltage to tester. Check for 12-volts at #2 terminal of harness connector. Repair wiring or terminals if 12-volts is not available. Replace tester if 12-volts is available.

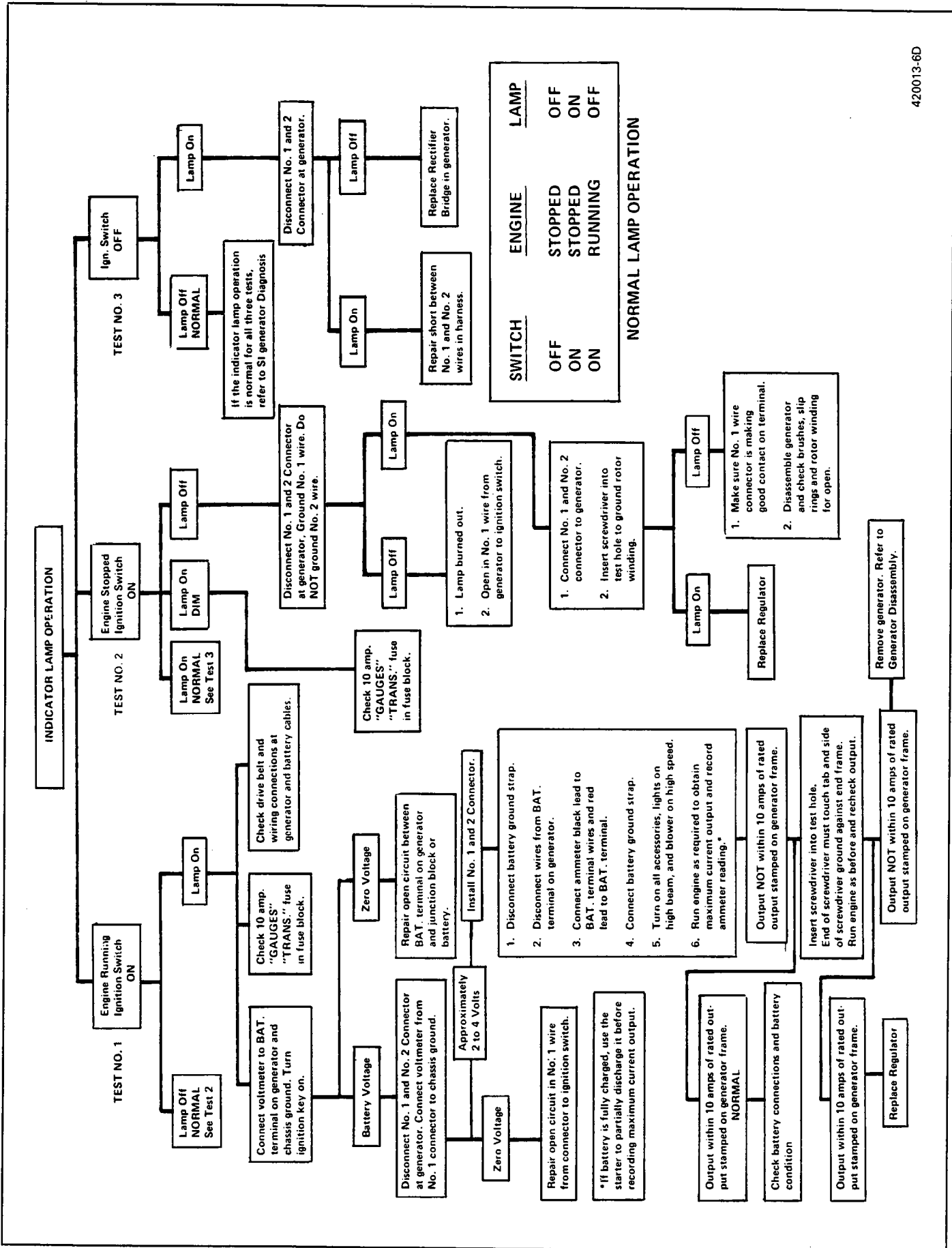

Figure 6D-13 Charge Light Operation

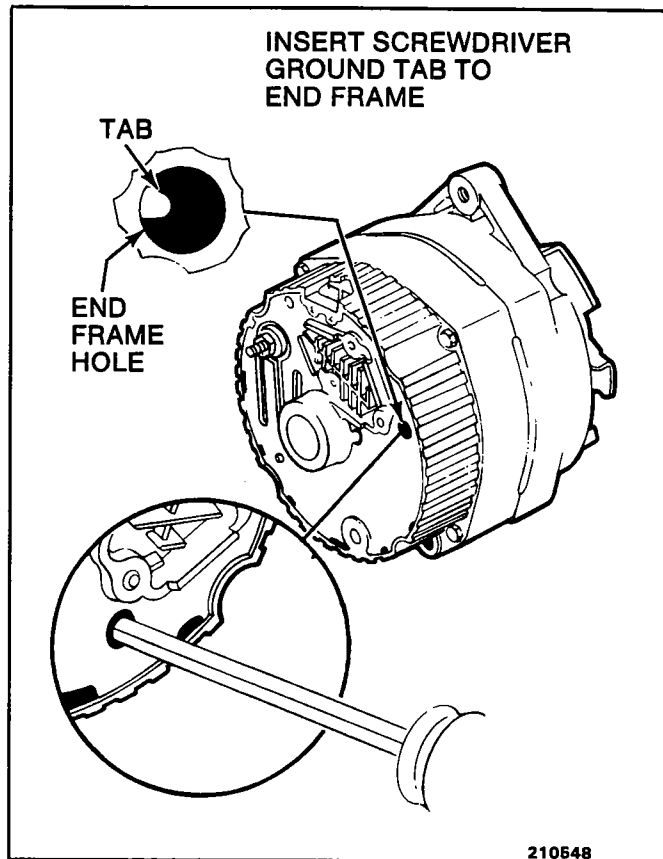

Figure 6D-14 Generator Test Hole

2. **Engine at Fast Idle:** (Lights and Accessories Off)
  - a. Light off--Charging system good, DO NOT remove generator.
  - b. Light on--Indicates a component failure within the generator. Remove generator and check diode trio, rectifier bridge and stator.
  - c. Light flashing--Indicates a problem within the generator. Remove generator and check regulator, rotor field coil, brushes and slip rings.

### Voltage Regulator Test

1. Connect a fast charger and a voltmeter to the battery as shown in Figure 6D-16.
2. Turn on the ignition and slowly increase the charge rate. The generator light in the car will dim at the voltage regulator setting. Voltage regulator setting should be a minimum of 13.5 volts and a maximum of 16.0 volts.

This test works if the rotor circuit is good, even if the stator rectifier bridge or diode trio is bad.

### ON CAR SERVICE

The generator does not require periodic lubrication. The rotor shaft is mounted on ball bearings at the drive end and roller bearings at the slip ring end, and each contains a permanent grease supply. At periodic intervals, check mounting bolts for tightness and adjust belt tension.

- When adjusting belt tension, apply pressure at center of generator, never against either end frame.

### Removal

1. Disconnect negative battery cable at battery.  
**CAUTION: Failure to observe this step may result in an injury from hot battery lead at generator.**

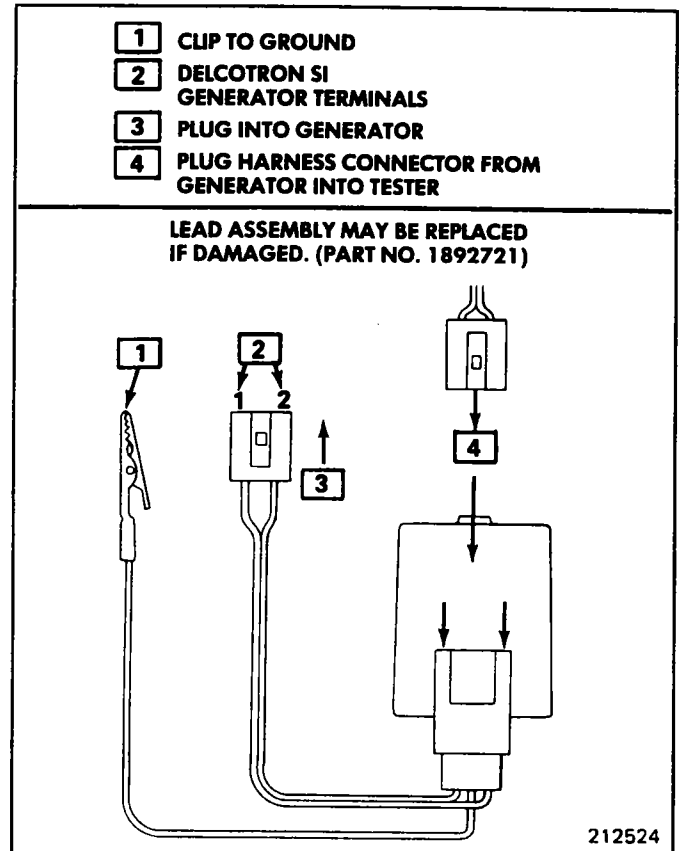

Figure 6D-15 Generator Diagnostic Tester

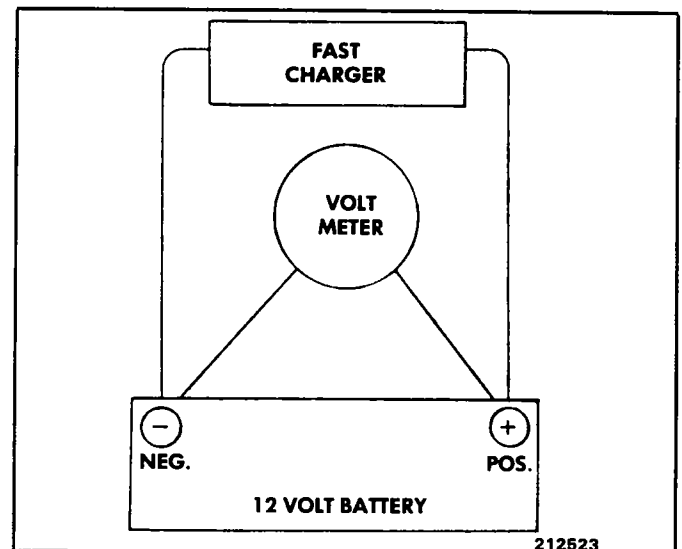

Figure 6D-16 On-Car Voltage Regulator Test

2. Remove two terminal plug and battery leads on back of generator.
3. Loosen adjusting bolts.
4. Remove generator drive belt.
5. Remove thru bolts which retain generator.
6. Remove generator from car.

### Installation

1. If removed from car, install generator to mounting bracket with bolts, washers and nuts. Do not tighten.
2. Install generator drive belt.
3. Tighten belt to the specified belt tension. See Section 0A Section for proper belt tensioning procedures.

## 6D-14 ENGINE ELECTRICAL

4. Tighten bolts.
5. Install generator terminal plug and battery leads to generator.
6. Connect negative battery cable.

### UNIT REPAIR

#### GENERATOR BENCH CHECK

To check the generator in a test stand, proceed as follows:

1. Make connections as shown in Figure 6D-17 except leave the carbon pile disconnected. **IMPORTANT** - Ground polarity of battery and generator must be the same. Use a fully charged battery, and a 10 ohm resistor rated at six watts or more between the generator No. 1 terminal and the battery.
2. Slowly increase the generator speed and observe the voltage.
3. If the voltage is uncontrolled with speed and increases above 15.5 volts on a 12-volt system, or 31 volts on a 24-volt system, test regulator with an approved regulator tester, and check field winding. **NOTE:** The battery must be fully charged when making this check.
4. If voltage is below 15.5 volts on a 12-volt system, or 31 volts on a 24-volt system, connect the carbon pile as shown.
5. Operate the generator at moderate speed as required and adjust the carbon pile as required to obtain maximum current output.
6. If output is within 10 amperes of rated output as stamped on generator frame, generator is good.
7. If output is not within 10 amperes of rated output, keep battery loaded with carbon pile, and ground generator field.
8. Operate generator at moderate speed and adjust carbon pile as required to obtain maximum output.
9. If output is within 10 amperes of rated output, test regulator with an approved regulator tester, and check field winding.
10. If output is not within 10 amperes of rated output, check the field winding, diode trio, rectifier bridge, and stator.

#### VOLTAGE REGULATOR BENCH CHECK

1. Connect voltmeter and fast charger to 12-volt battery as shown in Figure 6D-18.
2. Connect regulator and test light as shown, observe battery polarity.
3. Test light should be on.
4. Turn on fast charger and slowly increase charge rate. Observe voltmeter, light should go out at the voltage regulator setting. Voltage regulator setting should be a minimum of 13.5 volts and a maximum of 16.0 volts.

The test light is connected into the circuit, exactly as the rotor is when the regulator is inside the generator. The regulator shuts off the current to the test light when the regulator setting is reached. This voltage will vary with temperature differences.

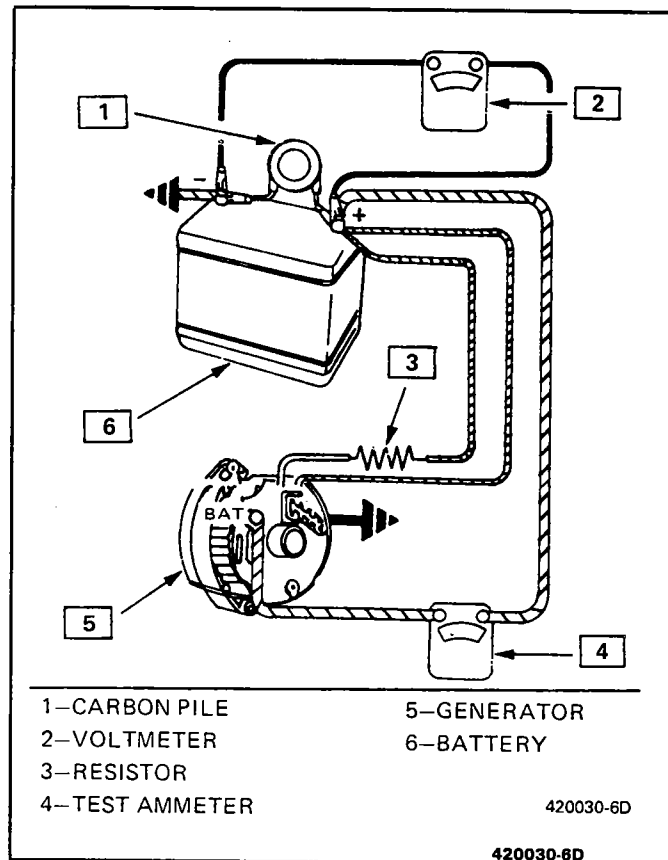

Figure 6D-17 Generator Bench Check

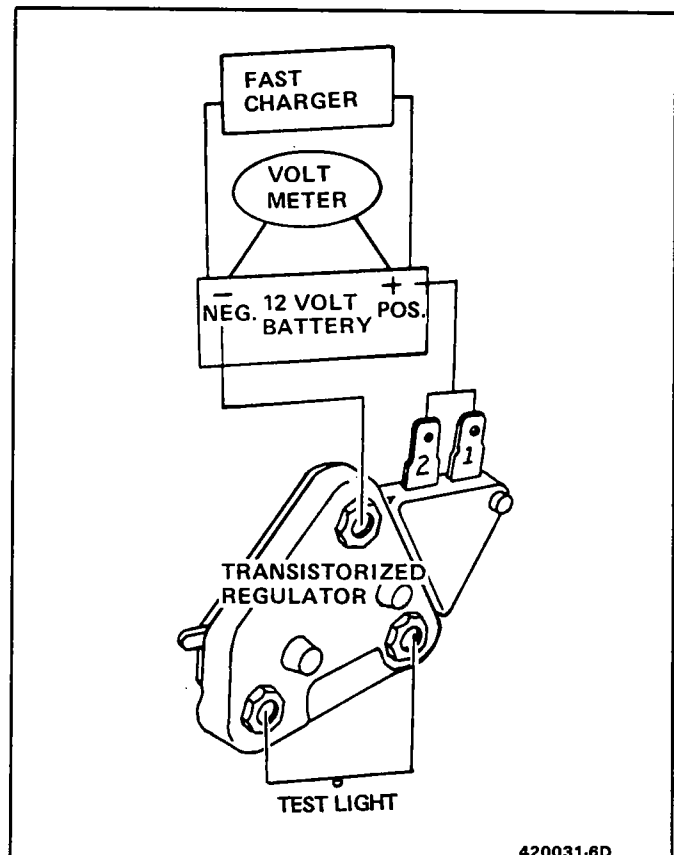
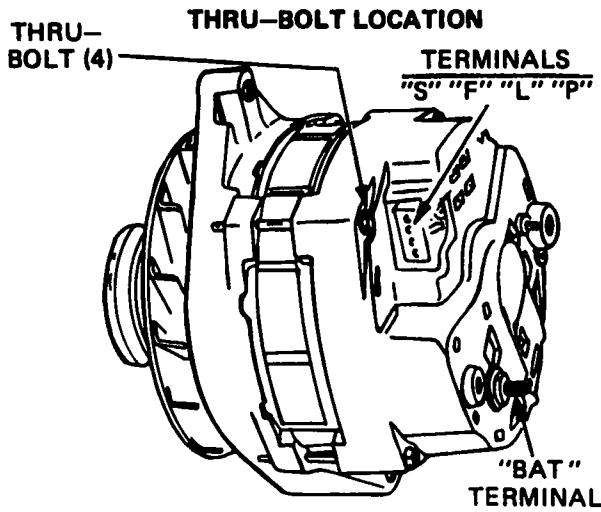
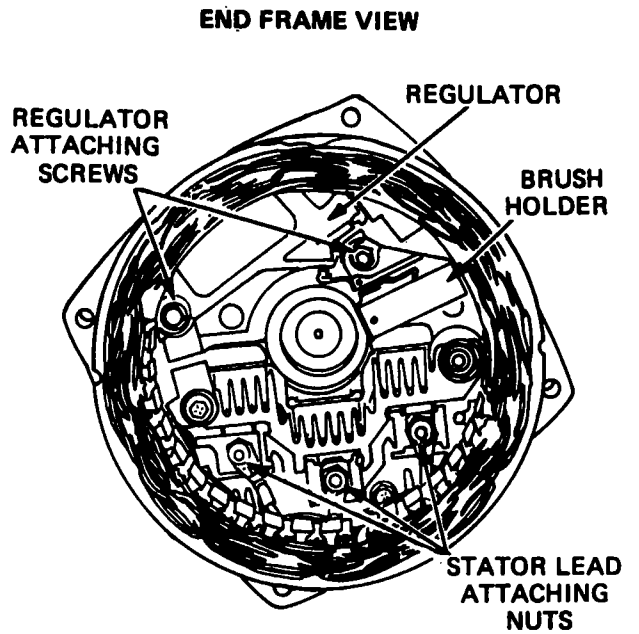

Figure 6D-18 Off-Car Voltage Regulator Test

## CS144 GENERATOR DISASSEMBLY TEST AND REASSEMBLY (GENERATOR REMOVED FROM ENGINE)



1. Make scribe marks on end frames to facilitate reassembly.
2. Remove thru-bolts and separate end frames.



5. Remove three attaching nuts and remove stator from end frame.

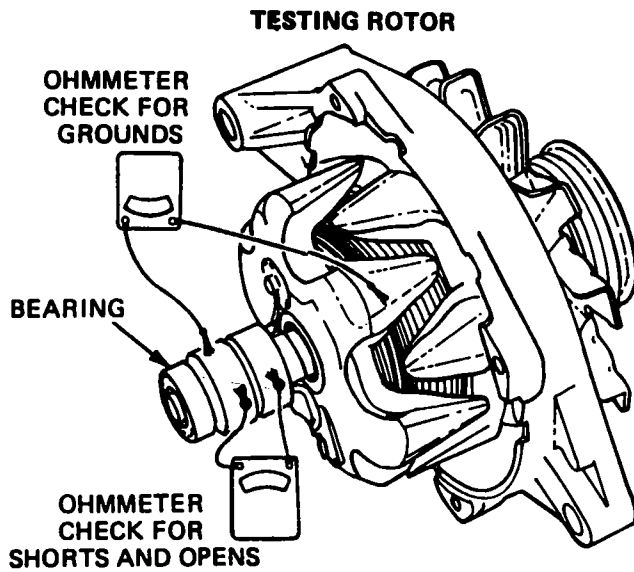

3. Check rotor for grounds with ohmmeter. Reading should be very high (infinite). If not, replace rotor.
4. Check rotor for shorts and opens. Should read ohms at 80°F per table. Replace rotor if outside range.

2.4 - 2.8 OHMS  
Models 1101250

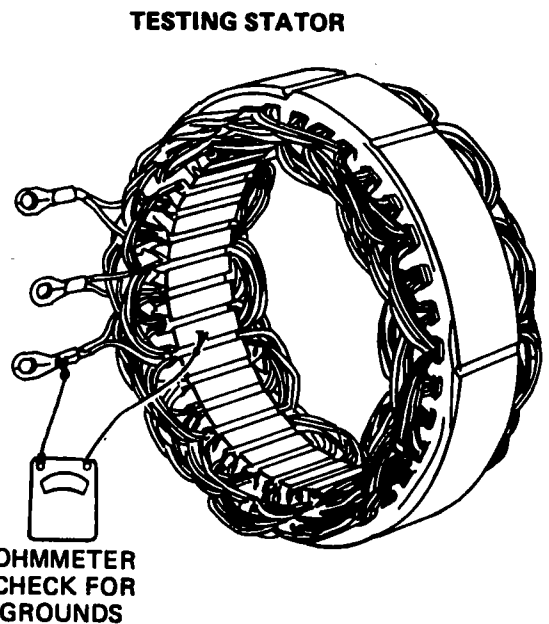

6. Check stator for grounds with ohmmeter. If reading is low, replace stator. Stator cannot be checked for opens and shorts with ohmmeter.

**REMOVING REGULATOR AND BRUSH HOLDER**

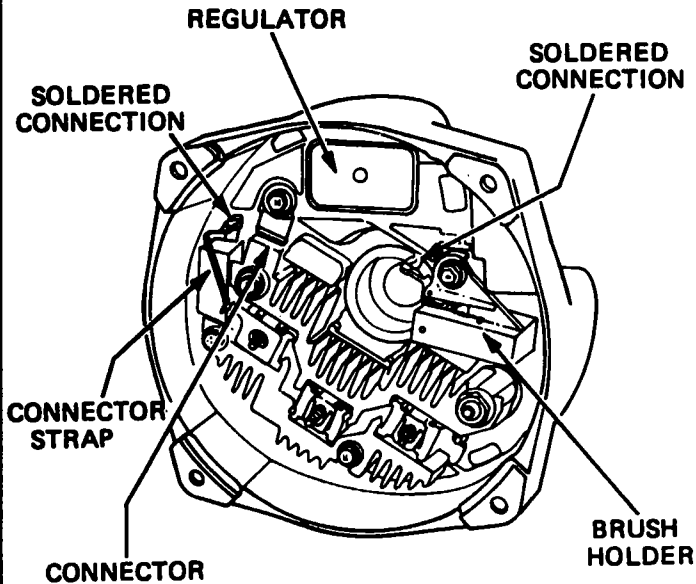

7. Unsolder connections, remove attaching screws and connector, separate regulator and brush holder from end frame.

**BRUSHES RETAINED IN HOLDER**

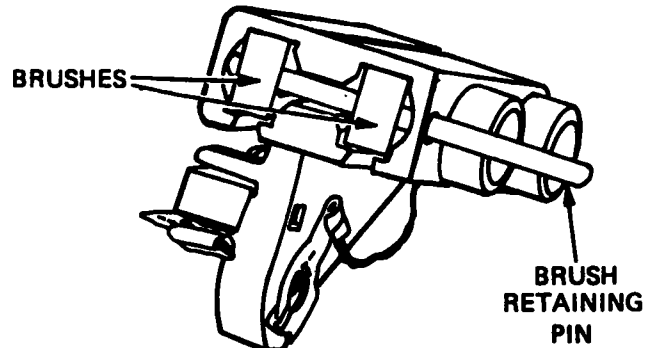

11. Clean brushes with soft dry cloth.
12. Put brushes in holder and hold with brush retaining pin.
13. Observe stack-up of parts in illustrations.

**TESTING RECTIFIER BRIDGE**

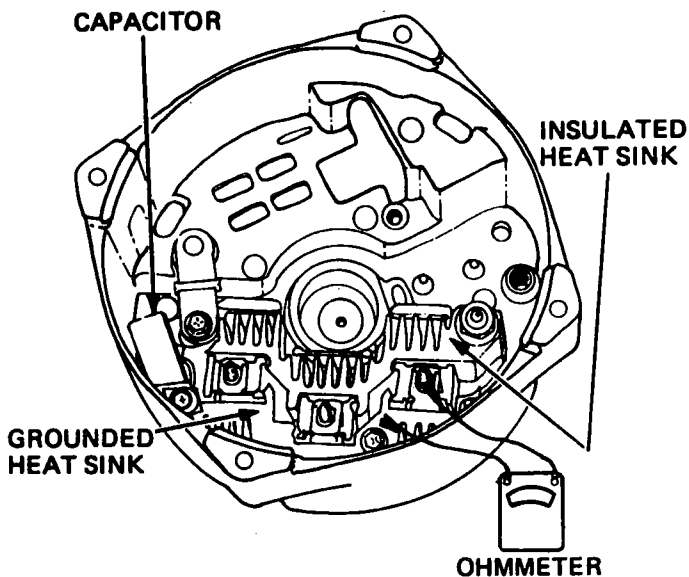

8. Check rectifier bridge with ohmmeter connected from grounded heat sink to flat metal on terminal. Reverse leads. If both readings are the same, replace rectifier bridge.
9. Repeat test between grounded heat sink and two other flat metal clips.
10. Repeat test between insulated heat sink and three flat metal clips.

**DRIVE END BEARING**

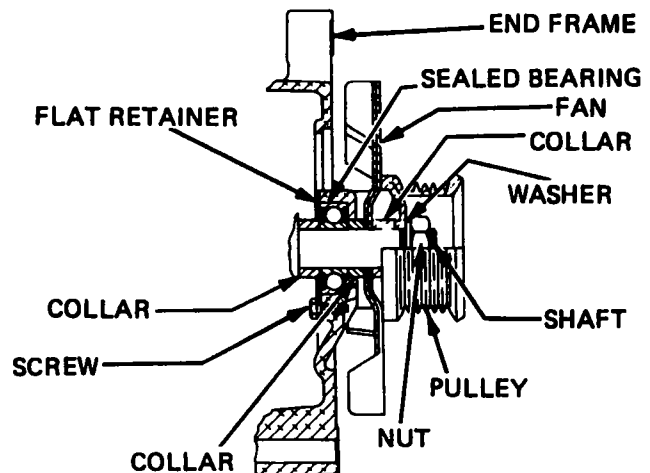

14. To remove rotor and drive end bearing, hold rotor with hex wrench in shaft end while removing nut. Push rotor from housing.
15. Remove plate and push bearing out.
16. Press against outer race to push bearing in. Bearing is double sealed, no added lubricant is required. Assemble retainer.
17. Press rotor into end frame. Assemble parts as illustrated. Torque shaft nut to 54-108 N•m (40-80lb.-ft.).
18. **NOTICE:** On slip ring end bearing, push bearing onto rotor shaft until stop is reached. A new bearing must be used whenever end frames are separated for repair.
19. Assemble regulator, brush holder and connector to end frame. Securely solder connection between regulator and brush holder, and connection between regulator and connector strap. Assemble stator to end frame.
20. Assemble end frames. Carefully guide slip ring end bearing outer race into casting.
21. Assemble thru-bolts.
22. Remove brush retainer pin.

H36234-6D-AJ

Figure 6D-20 CS 144 Generator Disassembly, Test and Reassembly (2 of 2)



## 10SI, 12SI, 15SI AND 27SI GENERATORS DISASSEMBLY, TEST AND REASSEMBLY (GENERATOR REMOVED FROM ENGINE)

### THRU-BOLT LOCATION

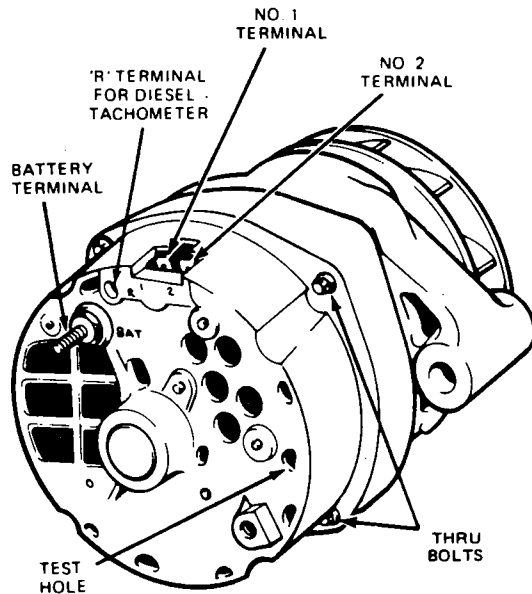

1. Make scribe marks on end frames to facilitate reassembly.
2. Remove four thru-bolts and separate drive end frame assembly from rectifier end frame assembly.

### TESTING STATOR

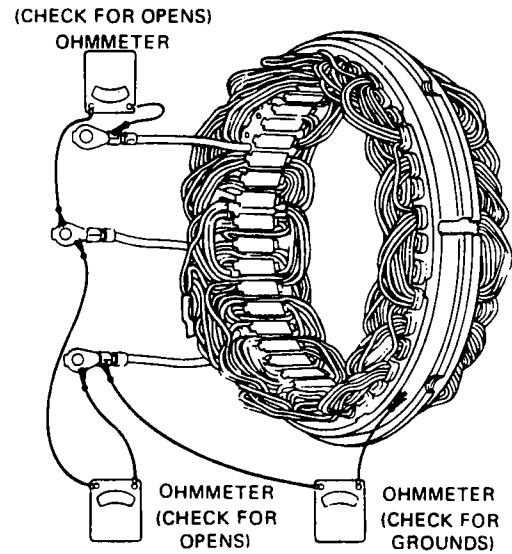

5. Check stator for opens with ohmmeter (two checks). If either reading is high (infinite), replace stator.
6. On all series, check stator for grounds. If reading is low, replace stator.

### END FRAME VIEW

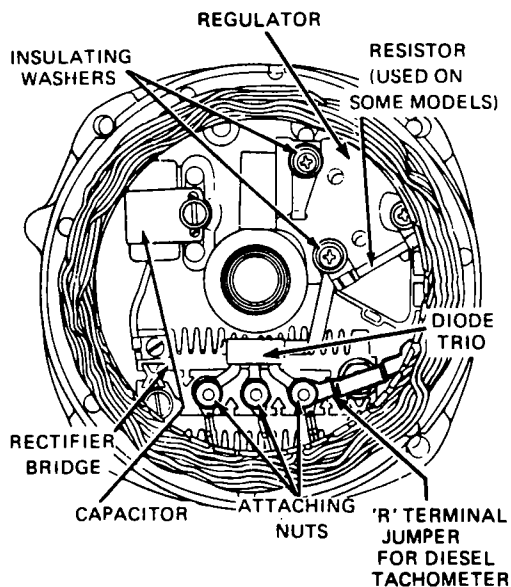

3. Remove three attaching nuts and three regulator attaching screws.
4. Separate stator, diode trio and regulator from end frame. The regulator cannot be tested on the work bench except with a regulator tester.

### TESTING ROTOR

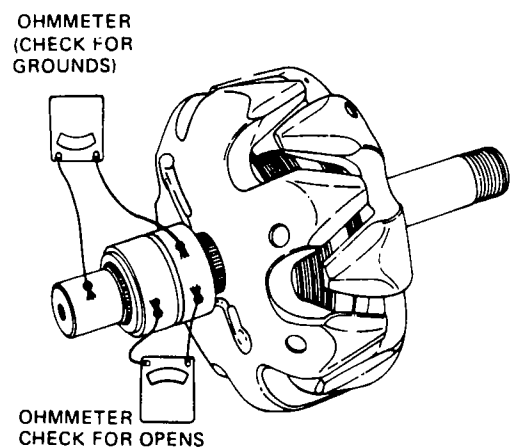

7. Check rotor for grounds with ohmmeter. Reading should be very high (infinite). If not, replace rotor.
8. Check rotor for opens. Should read 2.4-3.5 ohms. If not, replace rotor.

3B6D4

Figure 6D-20A 12 SI Generator Disassembly, Test, and Reassembly 1 of 2

TESTING TRIO

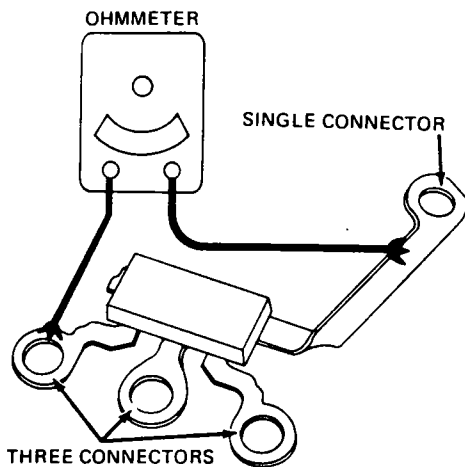

9. To check diode trio, connect ohmmeter as shown, then reverse lead connections. Should read high and low. If not, replace diode trio.
10. Repeat same test between single connector and each of other connectors.

BRUSHES RETAINED IN HOLDER

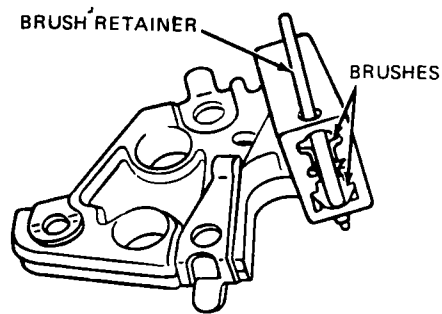

14. Clean brushes with soft, dry cloth.
15. Put brushes in holder and hold with brush retainer wire.

TESTING RECTIFIER BRIDGE

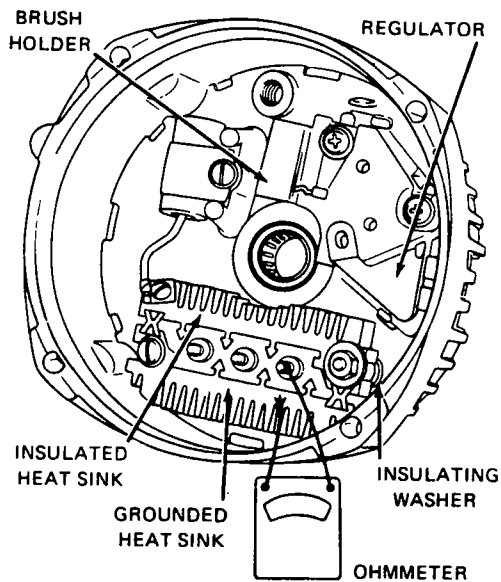

11. Check rectifier bridge with ohmmeter connected from grounded heat sink to flat metal on terminal, not the stud. Reverse leads. If both readings are the same, replace rectifier bridge.
12. Repeat test between grounded heat sink and other two flat metal clips.
13. Repeat test between insulated heat sink and three flat metal clips, not the stud. To replace bridge, remove attaching screws.

DRIVE END BEARING

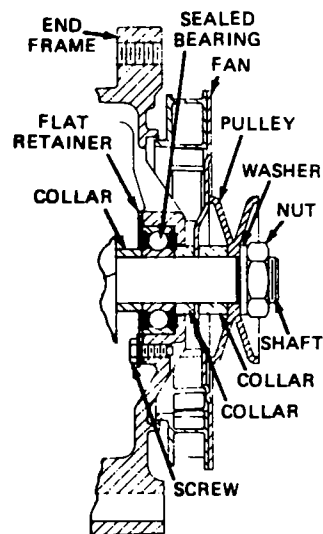

16. Observe stack-up of parts in both illustrations. To remove rotor and drive end bearing, remove shaft nut, washer and pulley, fan and collar. Push rotor from housing.
17. Remove retainer plate inside drive end frame and push bearing out. Clean all parts with soft cloth.
18. Press against outer race to push bearing in. The 12SI uses a sealed bearing -- no lubricant is required. Assemble retainer plate.
19. Press rotor into end frame. Assemble collar, fan, pulley, washer and nut. Torque shaft nut to 54 - 82 N-m (40 - 60 ft. lbs.).

RECTIFIER END BEARING

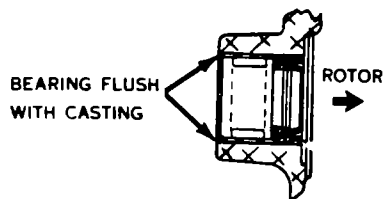

20. Push slip ring end bearing out from outside toward inside of end frame.
21. Place flat plate over new bearing, press from outside toward inside until bearing is flush with end frame.
22. Assemble brush holder, regulator, resistor, diode trio, rectifier bridge and stator to slip ring end frame.
23. Assemble end frames together with thru-bolts. Remove brush retainer wire.

3B6D5

Figure 6D-20B 12 SI Generator Disassembly, Test, and Reassembly 2 of 2

<b>GENERATOR USAGE CHART</b>			
<b>A SERIES</b>			
<b>Engine</b>	<b>Rated Output</b>	<b>Part Number</b>	<b>Model</b>
2.5L VIN R LR8	100A	1101143	CS130
	85A	1101142	CS130
2.8L VIN W LB6	105A	1101246	CS130
	100A	1101136	CS130
	85A	1101135	CS130
3.8L VIN 3 LG3	120A	1101182	CS144
	105A	1101181	CS130
	85A	1101179	CS130
<b>B SERIES</b>			
5.0L VIN Y LV2	78A	1105565	12S1
	94A	1105493	12S1
<b>C SERIES</b>			
3.8L VIN 3 LG3	108A	1101250	CS144
<b>E SERIES</b>			
3.8L VIN 3 LG3	108A	1105615	CS144
<b>G SERIES</b>			
3.8L VIN A LD5	94A	1105444	12S1
	56A	1100239	12S1
	70A	1105197	15S1
	78A	1100200	12S1
	85A	1105548	15S1
5.0L VIN Y LV2	78A	1100200	12S1
3.8L VIN 7 LC2	120A	1101183	CS144
<b>H SERIES</b>			
3.8L VIN 3 LG3	108A	1101250	CS144
<b>J SERIES</b>			
2.0L VIN K LT2	85A	1101144	CS130
	100A	1101145	CS130
	105A	1101190	CS130
	74A	1105697	CS121
2.0L VIN 1 LL8	85A	1105701	CS130
	74A	1105697	CS121
2.0L VIN M LT3	100A	1101191	CS130
	85A	1105701	CS130
<b>N SERIES</b>			
2.5L VIN U L68	85A	1101123	CS130
	100A	1101124	CS130
3.0L VIN L LN7	85A	1101125	CS130
	100A	1101126	CS130
	108A	1101184	CS130

H40020-6D-R1

Figure 6D-20C Generator Chart

# IGNITION SYSTEM

## CONTENTS

General Description .....	6D-20	Diagnosis .....	6D-25
H.E.I. Distributor System .....	6D-20	Service Precautions .....	6D-25
Computer Controlled Coil Ignition .....	6D-20	On-Car Service .....	6D-25
Distributor Cover .....	6D-20	H.E.I. Distributor .....	6D-26
Secondary Wiring .....	6D-21	Distributor Removal and Installation .....	6D-26
Spark Plugs .....	6D-21	Module Removal and Installation .....	6D-26
Ignition Switch .....	6D-25	Pick Up Coil Removal and Installation .....	6D-26
Electronic Spark Control .....	6D-25	Rotor Removal and Installation .....	6D-26
Sensor .....	6D-25	Coil Removal and Installation .....	6D-26
Controller .....	6D-25	Camshaft and Crankshaft Sensors .....	6D-27

There are two types of ignition systems in use. The standard High Energy Ignition System (HEI) and the Computer-Controlled Coil Ignition System (C<sup>3</sup>I). (See Description, Operation and Diagnosis in Section 6E3.)

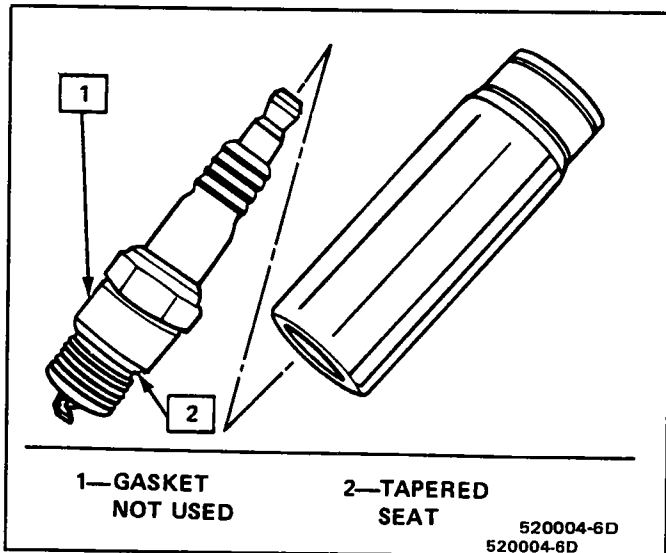

Figure 6D-21 Spark Plug-Tapered Seat

### Distributor System H.E.I.

The High Energy Ignition distributor H.E.I. with Electronic Spark Timing (EST) combines all ignition components in one unit (Figure 6D-21). The ignition coil is mounted either in the distributor cap or it is remotely mounted.

The distributor has a magnetic pick-up assembly located inside the distributor which contains a permanent magnet, a pole piece with internal teeth and a pick-up coil. When the teeth of the timer core, rotating inside the pole piece, line up with the teeth of the pole piece, an induced voltage in the pick-up coil signals the electronic module to trigger the coil primary circuit. The primary current decreases and a high voltage is induced in the ignition coil secondary winding which is directed through the rotor and secondary leads to fire the spark plugs. The capacitor in the distributor is for radio noise suppression.

All spark timing changes in the H.E.I. (EST) distributor are done electronically by an Electronic Control Module (ECM) which monitors information from various engine sensors, computes the desired spark timing and signals the distributor to change the timing accordingly. A back-up spark advance system is incorporated to signal the ignition module in case of (ECM) failure. No vacuum or mechanical advance are used. See Figs. 6D-37 through

6D-41 for H.E.I. and (EST) diagnosis. Further (EST) information is found in sections 6E Emissions Control, 8 Chassis Electrical and 8A Electrical Troubleshooting.

### Distributorless Ignition (C<sup>3</sup>I)

The distributorless ignition system uses a "waste spark" method of spark distribution. Each cylinder is paired with its opposing cylinder in the firing order, so that one cylinder on compression fires simultaneously with its opposing cylinder on exhaust. Since the cylinder on exhaust requires very little of the available voltage to fire its plug, most of the voltage is used to fire the cylinder on compression. The process reverses when the cylinders reverse roles. There are three coils for a 6-cylinder engine (C<sup>3</sup>I).

Components of the C<sup>3</sup>I system are a coil pack, ignition module, dual hall effect sensor, interrupter rings, and the ECM. The coil pack consists of three separate ignition coils enclosed in one housing and serviced as a unit. These coils operate in the same manner as previous coils. Three coils are needed because each coil only fires for two cylinders. The ignition module is located under the coil pack and is connected to the ECM by a 14 pin connector. The ignition module controls the primary circuit to the coils, turning them on and off, and controls spark timing below 400 rpm and if the ECM bypass circuit becomes open or grounded. (See Section 6E.) The dual hall effect sensor is a combination cam and crankshaft sensor, mounted on the front cover behind the crankshaft balancer. Interrupter rings, mounted on the crankshaft balancer, pass through slots in the dual hall effect sensor and provide timing information to the ECM. The interrupter ring with the single window functions as the cam sensor and identifies the correct firing sequence. The interrupter ring with three windows functions as a crank sensor, and is used by the ignition module to trigger each coil at the proper time and to inform the ECM of crankshaft position and rpm.

This system uses EST and C<sup>3</sup>I control wires from the ECM, as with distributor systems. The ECM controls timing using crankshaft position, engine rpm, engine temperature and volume of intake air (from MAP).

Further EST information is found in Sections 6E3 and 8A.

### Distributor Cover

On Engine Code "3", a distributor cover is used as shown in Figure 6D-22. A lock tab is located at the flattened part of the cover side and a release tab is located on the rounded side of the cover.

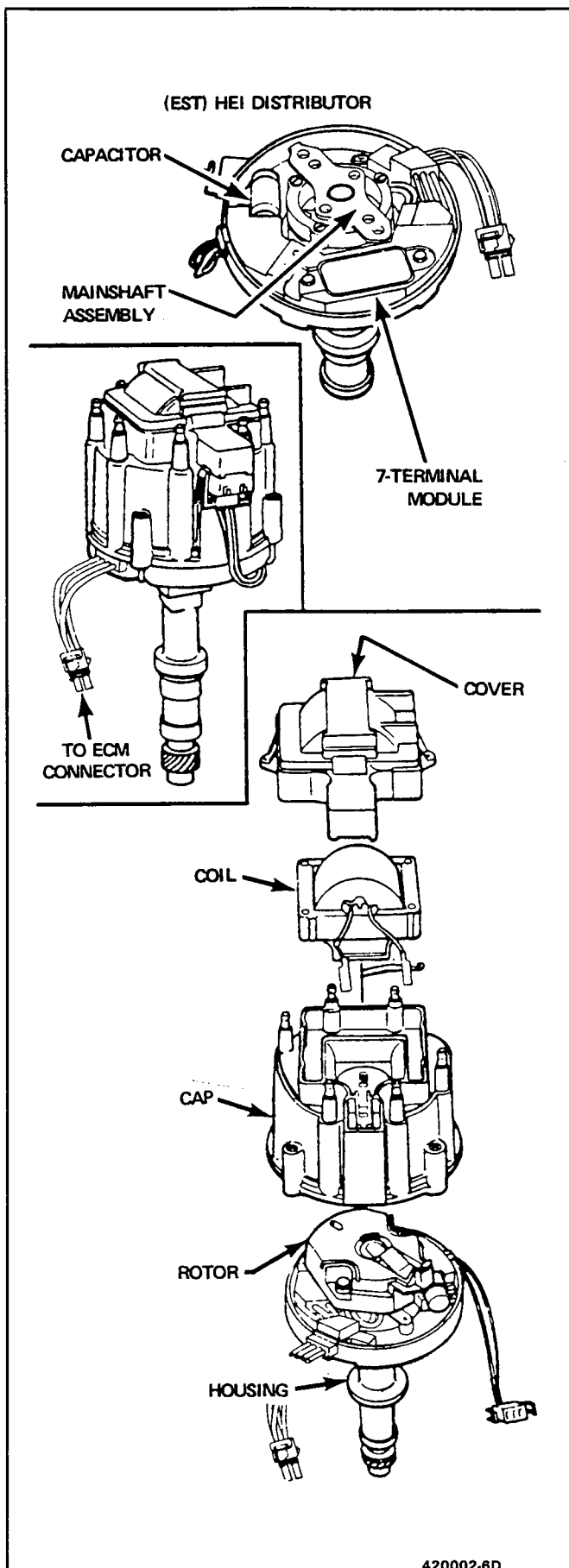
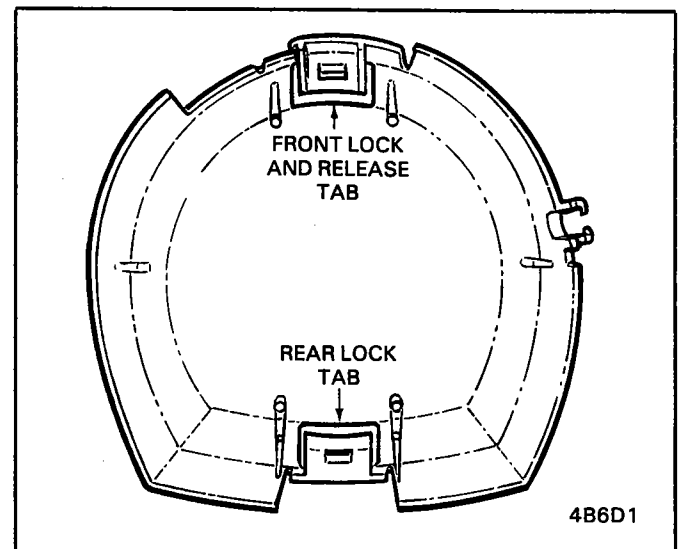

Figure 6D-22 (EST) Distributor



6D-23 Distributor Cap Cover

### Secondary Wiring

The spark plug wiring used with the HEI system is a carbon impregnated cord conductor encased in an 8MM (5/16") diameter silicone rubber jacket. The silicone wiring will withstand very high temperatures and also provides an excellent insulator for the higher voltage of the HEI system. The silicone spark plug boots form a tight seal on the plug and **the boot should be twisted 1/2 turn before removing**. Care should also be exercised when connecting a timing light or other pick-up equipment. Do not force anything between the boot and wiring, or through the silicone jacket. Connections should be made in parallel using an adapter. **DO NOT** pull on the wire to remove. Pull on the boot, or use a tool designed for this purpose.

### Spark Plug Harness-LN7

The spark plug harness is held together by a two piece plastic housing on the front and rear of the engine.

The housing has slots built in that slip over mounting pins on the rocker arm cover.

Lock tangs on the housing hold the harness assembly to the rocker arm cover and lock tangs and lock clips hold the covers to the housing assembly. The lock clip can be pushed together to remove the outer cover. On the front cover two lock tangs also help to hold the cover to the assembly.

Any time that the housing and/or wires are removed, make sure that wires and/or housing are installed as shown.

Each plug wire has the number of the spark plug written on it. Also observe in Figure 6D-29 that the number one plug wire crosses under the number three and five wire.

### Spark Plugs

Resistor type, tapered seat spark plugs are used on all engines. No gasket is used on these tapered seat plugs. See Figure 6D-23 for an explanation of letter coding on spark plugs.

Always replace plugs with the correct plug listed on the Vehicle Emission Control Information Label. Correct plug gap is also listed on the Label.

Worn or dirty plugs may give satisfactory operation at idling speed, but under operating conditions they frequently fail. Faulty plugs are indicated in a number of ways: poor fuel economy, power loss, loss of speed, hard starting and general poor engine performance.

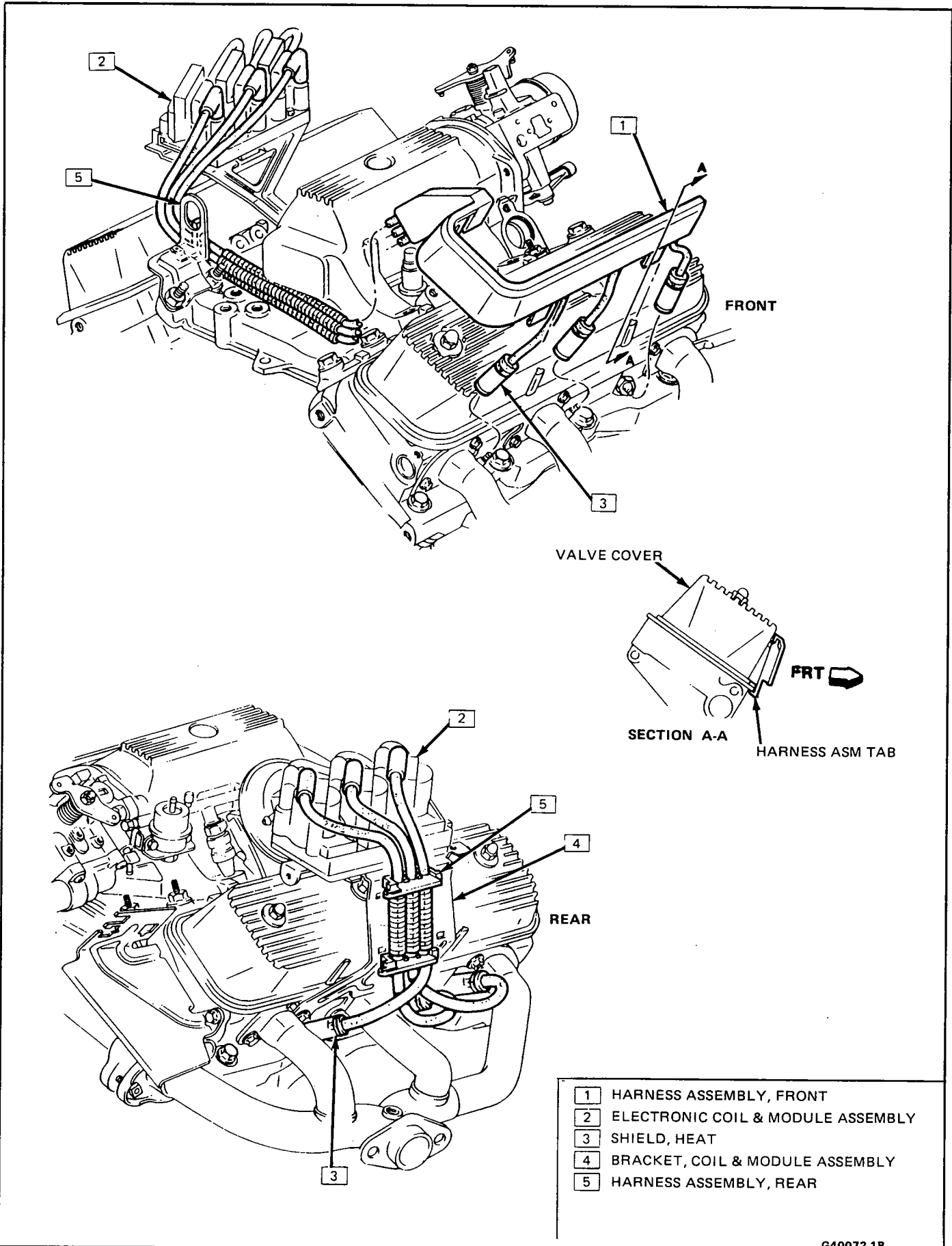
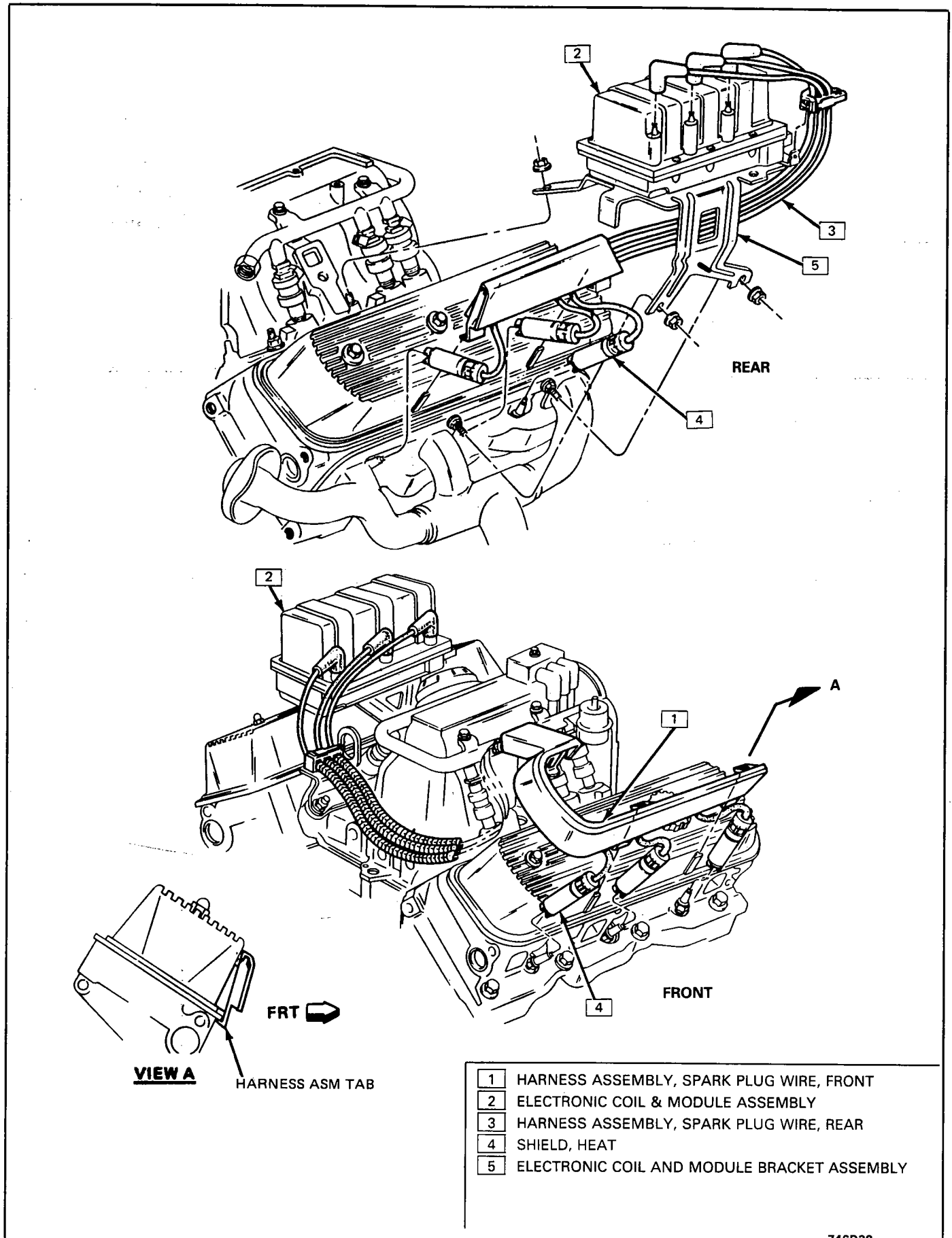

Figure 6D-24 Plug Wire Harness-LG3



- 1 HARN ASM, SPARK PLUG WIRE, FRONT
- 2 ELECTRONIC COIL & MODULE ASSEMBLY
- 3 HARN ASM, SPARK PLUG WIRE, REAR
- 4 SHIELD, HEAT
- 5 ELECTRONIC COIL AND MODULE BRACKET ASSEMBLY

Figure 6D-25 Plug Wire Harness-LN7

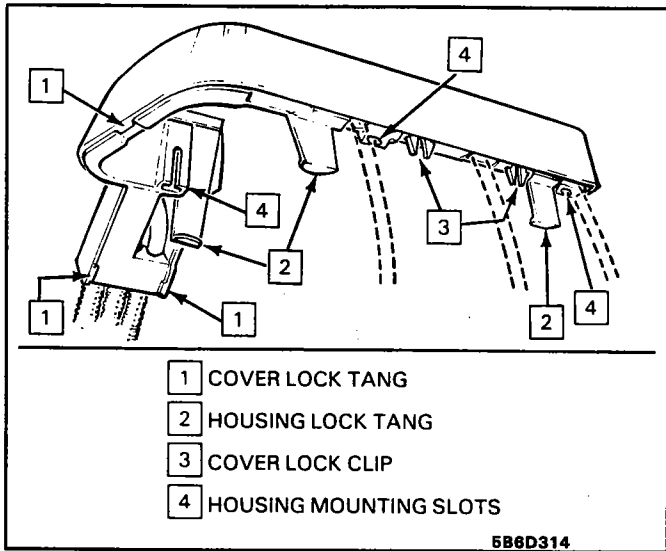

Figure 6D-26 Front Assembly Lock Tangs and Clip

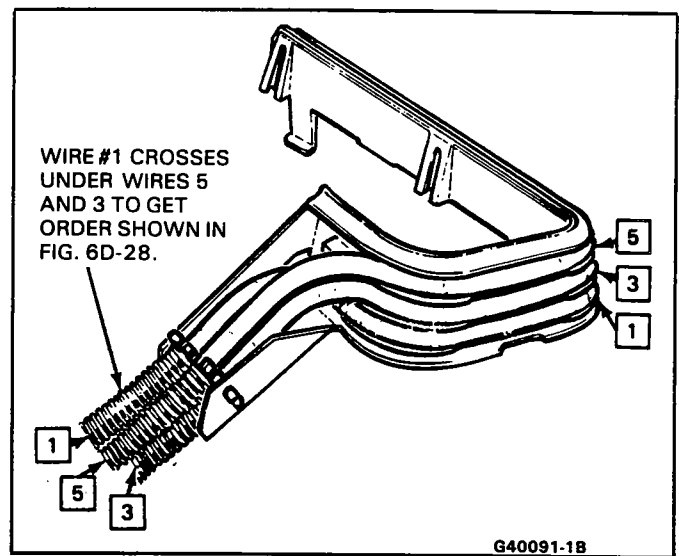

Figure 6D-29 Front Harness Layout

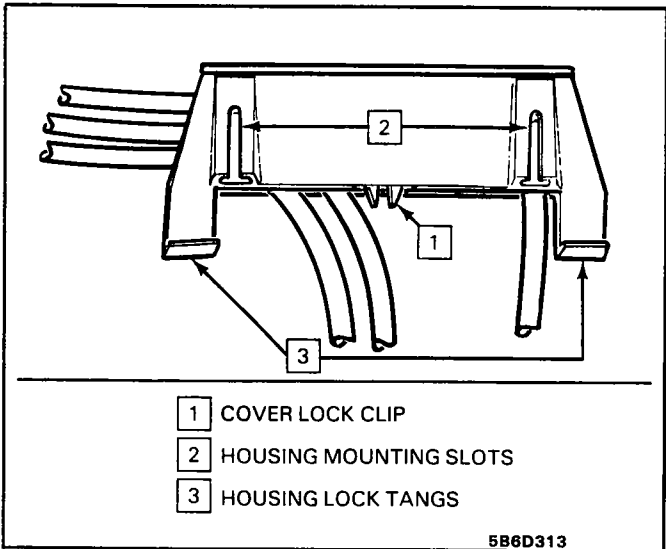

Figure 6D-27 Rear Assembly Lock Tangs and Clip

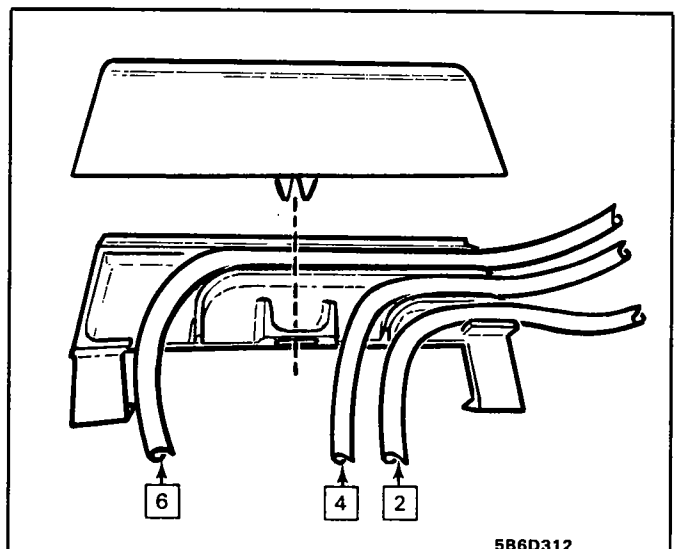

Figure 6D-30 Rear Harness Layout

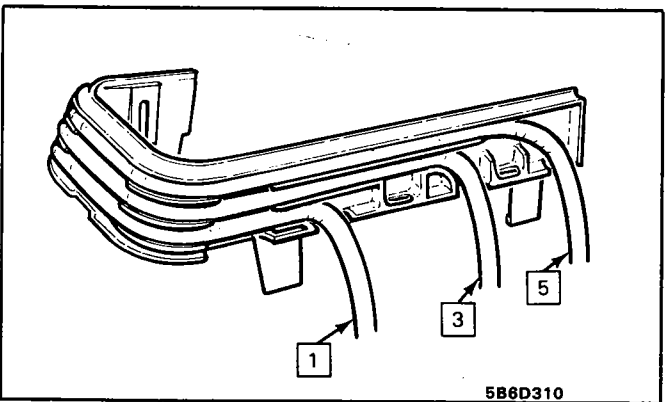

Figure 6D-28 Front Harness Layout

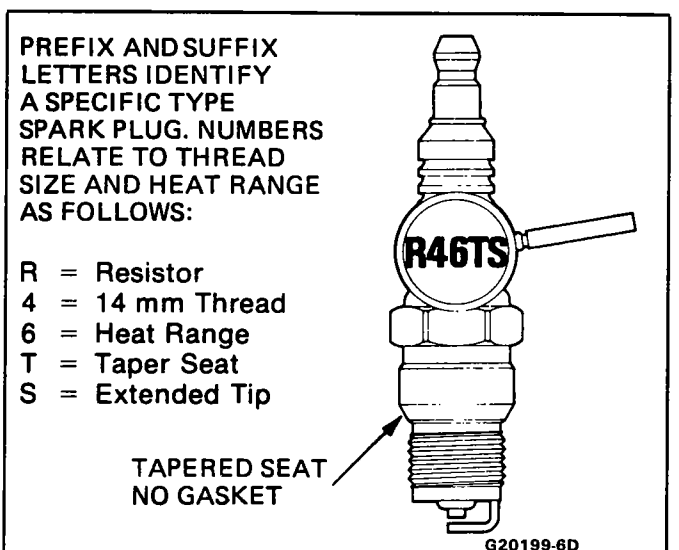

Figure 6D-31 Spark Plug Example

Spark plugs may also fail due to carbon fouling, excessive gap or a broken insulator.

Fouled plugs may be indicated by checking for black carbon deposits. The black deposits are usually the result of slow-speed driving and short runs where sufficient engine operating temperature is seldom reached. Worn pistons, rings, faulty ignition, over-rich carburetion and spark plugs which are too cold will also result in carbon deposits.

Excessive gap wear, on plugs of low mileage, usually indicates the engine is operating at high speeds or loads that are consistently greater than normal or that a plug which is



too hot is being used. Electrode wear may also be the result of plug overheating, caused by combustion gases leaking past the threads due to insufficient torquing of the spark plug. Excessively lean carburetion will also result in excessive electrode wear.

Broken insulators are usually the result of improper installation or carelessness when regapping the plug. Broken upper insulators usually result from a poor fitting wrench or an outside blow. The cracked insulator may not show up right away, but will as soon as oil or moisture penetrates the crack. The crack is usually just below the crimped part of shell and may not be visible.

Broken lower insulators usually result from carelessness when regapping and generally are visible. This type of break may result from the plug operating too "hot," which may happen in periods of high-speed operation or under heavy loads. When regapping a spark plug, always make the gap adjustment by bending the ground (side) electrode. Spark plugs with broken insulators should always be replaced.

Normal service is assumed to be a mixture of idling, slow speed, and high speed driving. Occasional or intermittent highway speed driving is needed for good spark plug performance because it gives increased combustion heat that burns away any excess deposits of carbon or oxides that have built up from frequent idling or continual stop-and-go driving. Spark plugs are protected by an insulating nipple made of special heat-resistant material which covers the spark plug terminal and extends downward over a portion of the plug insulator. These nipples prevent flash-over which causes engine mis-firing. Do not mistake corona discharge for flash-over or a shorted insulator. Corona is a steady blue light appearing around the insulator, just above the shell crimp. It is the visible evidence of high-tension field and has no effect on ignition performance. Usually it can be detected only in darkness. This discharge may repel dust particles, leaving a clear ring on the insulator just above the shell. This ring is sometimes mistakenly regarded as evidence that combustion gases have blown out between shell and insulator.

Use care when removing spark plug wire boots from spark plugs. Twist the boot 1/2 turn before removing, and pull on the **boot only** to remove the wire.

Spark plugs without a tapered seat ... 34 N·m (25 ft. lbs.)  
Spark plugs with a tapered seat ..... 20 N·m (15 ft. lbs.)

## Ignition Switch

The mechanical switch is located in the steering column on the right hand side just below the steering wheel. The electrical switching portion of the assembly is separate from the key and lock cylinder. However, both are synchronized and work in conjunction with each other through the action of the actuator rod assembly.

For a complete explanation of the key and lock cylinder, and the actuator rod assembly, see **STEERING**, Section 3B. See Section 8 for the electrical switching.

## (ESC) Electronic Spark Control

Electronic Spark Control (ESC) used on some engines, modifies (retards) the spark advance when detonation occurs. The retard mode is held for 20 seconds after which the spark control will again revert to (EST). There are three basic components in the (ESC) system.

### Sensor

Most (ESC) sensors are mounted on the engine block assembly and detect the presence (or absence) and intensity of detonation or spark knock. The output is an electrical

signal that goes to the controller. A sensor failure would allow no retard.

### Controller

The (ESC) controller processes the sensor signal into a command signal to the distributor to adjust spark timing. The process is continuous so that the presence of detonation is monitored and controlled. The controller is a hard wired signal processor and amplifier which operates from 6 to 16 volts. Controller failure would cause no ignition, no retard or full retard. The controller has no memory storage. See Section 6E for (ESC) Diagnosis. Electrical Diagrams of this circuit are shown in sections 8, and 8A Electrical Troubleshooting.

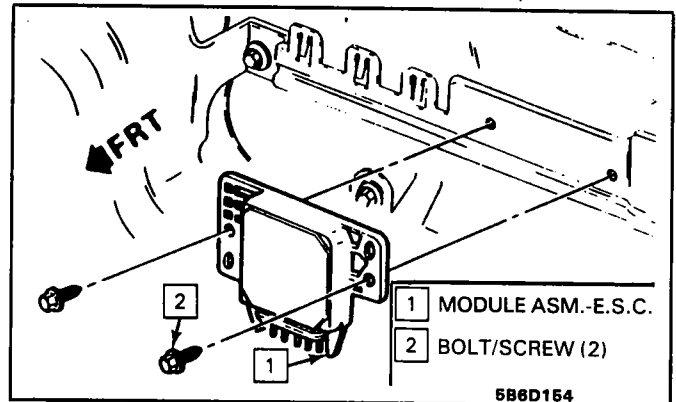

Figure 6D-31A E.S.C. Module-LN7

## DIAGNOSIS

### Service Precautions

1. When making compression checks, disconnect the ignition switch feed wire at the distributor. When disconnecting this connector, **do not** use a screwdriver or tool to release the locking tab, as it may break.
2. No periodic lubrication is required. Engine oil lubricates the lower bushing and an oil-filled reservoir provides lubrication for the upper bushing.
3. The tachometer (TACH) terminal is next to the ignition switch (BAT) connector on the distributor cap.

**NOTICE:** The tachometer terminal must **NEVER** be allowed to become grounded, as damage to the module and/or ignition coil can result.

Some tachometers currently in use may **NOT** be compatible with the High Energy Ignition System. Consult the manufacturer of the tachometer if questions arise.

4. Dwell adjustment is controlled by the module, and cannot be adjusted.
5. The material used to construct the spark plug wires is very soft. This wires will withstand more heat and carry a higher voltage, but scuffing and cutting become easier.

See the appropriate 6E Section for H.E.I. Diagnosis.

## ON CAR SERVICE

See Figs. 6D-37 thru 6D-41 for distributor disassembly test and reassembly of individual distributor components when the distributor is removed from the vehicle. See On Car Service for distributor removal and installation and for component removal with distributor in

car. See Figures 6D-32 thru 6D-32B for HEI diagnosis and Figures 6D-32C and 6D32 for EST diagnosis.

**H.E.I. DISTRIBUTOR****Remove and Install**

1. Disconnect ignition switch battery feed wire and tachometer lead (if equipped) from distributor cap. Also release the coil connectors from the cap. (DO NOT use a screwdriver or tool to release the locking tabs.)
2. Remove distributor cap by turning four latches counterclockwise. Move cap out of the way.
3. Disconnect 4 terminal ECM harness from distributor.
4. If necessary remove secondary wires from cap, release wiring harness latches and remove wiring harness retainer. The spark plug wire numbers are indicated on the retainer.
5. Remove distributor clamp screw and hold-down clamp.
6. Note position of rotor, then pull distributor up until rotor just stops turning counterclockwise and again note position of rotor.
  - To insure correct timing of the distributor, the distributor must be INSTALLED with the rotor correctly positioned as noted.

If the engine was accidentally cranked after the distributor was removed, the following procedure can be used for installing:

- a. Remove No. 1 spark plug.
- b. Place finger over No. 1 spark plug hole and crank engine slowly until compression is felt.
- c. Align timing mark on pulley to "0" on engine timing indicator.
- d. Turn rotor to point between No. 1 and No. 8 spark plug towers on distributor cap on 5.0L engines, between No. 1 and No. 6 on 3.0L, and 3.8L between No. 1 and No. 2 on 2.8L and between No. 1 and No. 3 on 1.8L, 2.0L and 2.5L engines.
- e. Install distributor and connect ignition feed wire.
- f. Install distributor cap and spark plug wires.
- g. Check engine timing (see Set Ignition Timing below).

**DISTRIBUTOR J SERIES****Remove and Install (OHC Engine)**

1. Disconnect negative battery cable at battery.
2. Remove coil and spark plug wires.
3. Disconnect coil and E.S.T. connectors.
4. Remove two (2) distributor to engine nuts.
5. Remove distributor.
6. To install, reverse removal procedure. Tighten to 13-20 N·m (9-15 lb.ft.) after timing is set.

**Remove and Install**

1. Disconnect negative battery cable.
2. Remove air cleaner as outlined in Section 6E.
3. Remove distributor cap by rotating two latches counterclockwise.
4. Disconnect AIR pipe to exhaust manifold hose at AIR management valve.
5. Remove rear engine lift bracket bolt and nut off the stud and move assembly aside for access.
6. Mark position of distributor in block and remove distributor hold-down nut and clamp.

7. Rotate distributor to disengage from gear drive and pull upward for clearance to remove distributor and coil electrical connectors.
8. Reverse above steps to install. (Install clamp onto stud using a magnet with an extension handle).

**Module**

It is not necessary to remove the distributor from car.

**Removal**

1. Remove distributor cap and rotor.
2. Remove two module attaching screws, and lift module up.
3. Disconnect leads from module. (Observe color code on leads as these cannot be interchanged.)
4. Remove two module attaching screws.
5. Do not wipe grease from module or distributor base if same module is to be replaced. If a new module is to be installed, a package of silicone grease will be included with it. Spread the grease on the metal face of the module and on the distributor base where the module seats. This grease is necessary for module cooling.

**Installation**

To install, reverse removal procedure.

**Pick-Up Coil****Removal**

1. Remove distributor from car and follow instructions in Figs. 6D-38 and 6D-41.

**Rotor****Figure 6D-21**

1. Remove distributor cap.
2. The rotor is retained by two screws and is provided with a slot which fits over a square lug on the advance weight base, so that the rotor can be installed in only one position.

**Integral Ignition Coil****Figure 6D-32****Figures 6D-32A, 32B, and 32C****Removal**

1. Remove distributor cap.
2. Remove three coil cover attaching screws, and lift off cover.
3. Remove coil attaching screws and lift ignition coil and leads from cap.

**Installation**

To install, reverse removal procedure.

**IGNITION COIL J SERIES****Remove and Install**

1. Disconnect negative battery cable.
2. Raise vehicle on hoist.
3. Disconnect fuel pump outlet pipe to carburetor.
4. Disconnect fuel pump inlet hose.
5. Remove vacuum pipe bracket retaining nut at coil and move pipe aside for access.

6. Remove two fuel pump retaining nuts and remove fuel pump and gasket.
7. Remove coil mounting bolts and stud.
8. Disconnect electrical connectors.
9. Remove coil.
10. Installation is the reverse of removal.

## Capacitor

Figure 6D-22

The capacitor is part of the coil wire harness assembly. Since the capacitor is used only for radio noise suppression, it will seldom need replacement.

### Removal

1. Remove distributor cap and rotor.
2. Remove capacitor attaching screw and unplug connector from module. It may help to loosen the module.

### Installation

1. To install, reverse above procedure.
2. Install hold-down screw making sure ground lead is under screw.

## Sensor Adjustment

Figure 6D-33A

1. Disconnect negative battery cable.
2. Remove serpentine belt.
3. Raise vehicle.
4. Remove inner fender splash shield, if necessary.
5. Rotate the harmonic balancer until the interrupter ring(s) fills the sensor slot(s) and edge of interrupter window is aligned with edge of deflector on pedestal.
6. Check gap between sensor and interrupter on either side of interrupter ring using tool J-36179 (or equivalent).
7. Check clearance at two more positions 120° apart.
8. If found out of adjustment, loosen pinch bolt on sensor pedestal and using adjustment tool set correct clearance, and tighten pinch bolt.
9. Check clearance three times, 120° apart.
10. If interrupter ring contacts sensor at anytime during harmonic balancer rotation, the interrupter ring must be replaced.

## Crankshaft Sensor - A, C, H, E & N Series

### VIN A, L & 3

#### Removal

1. Disconnect negative battery cable.
2. Remove serpentine belt.
3. Raise vehicle on hoist.
4. Remove inner fender splash shield.
5. Remove crankshaft balancer bolt.
6. Slide balance toward the right fender/cradle (A & E Series)
7. Remove crankshaft balancer (C, H & N Series).
8. Remove crankshaft sensor mounting bolts and sensor.
9. Remove crankshaft sensor electrical connection.

**IMPORTANT:** When servicing requires that the "T" latch type wiring is disconnected, care must be taken to ensure proper reassembly of the harness connector and the "T" latch. Failure to do so may result in the intermittent loss of operation.

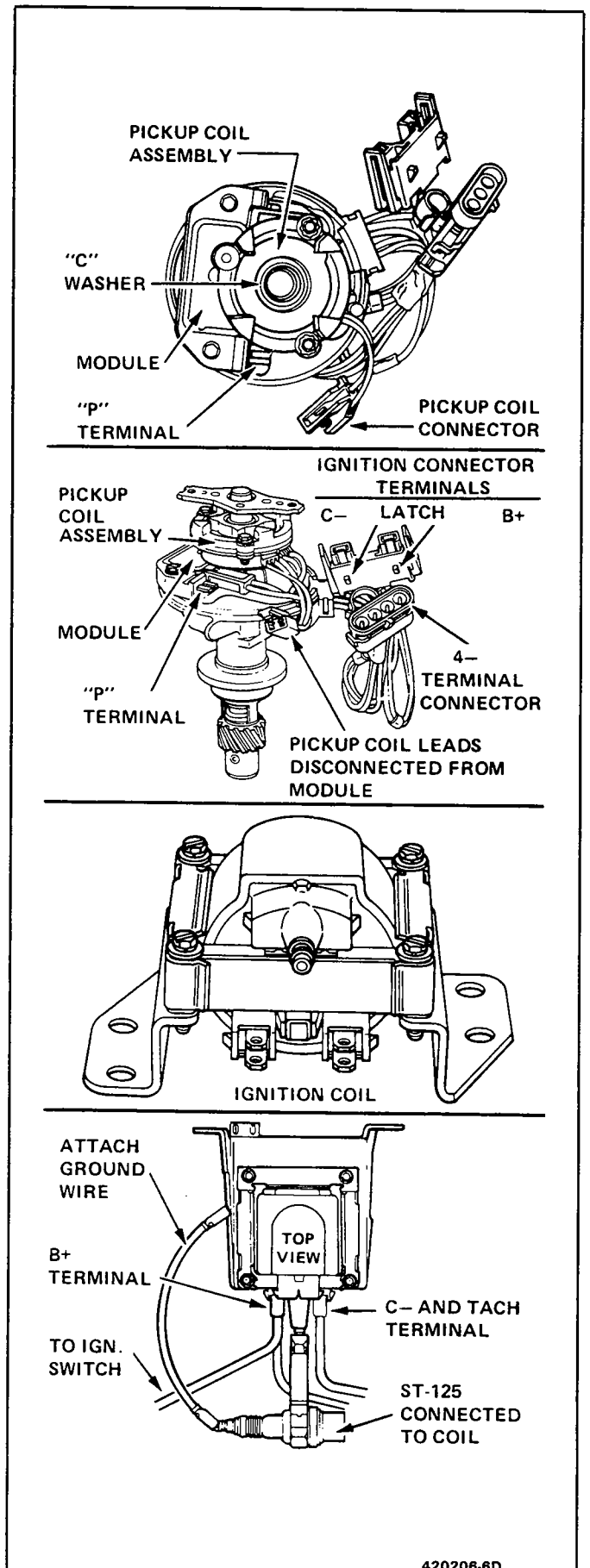

Figure 6D-33 L4 Distributor and Coil

420206-6D

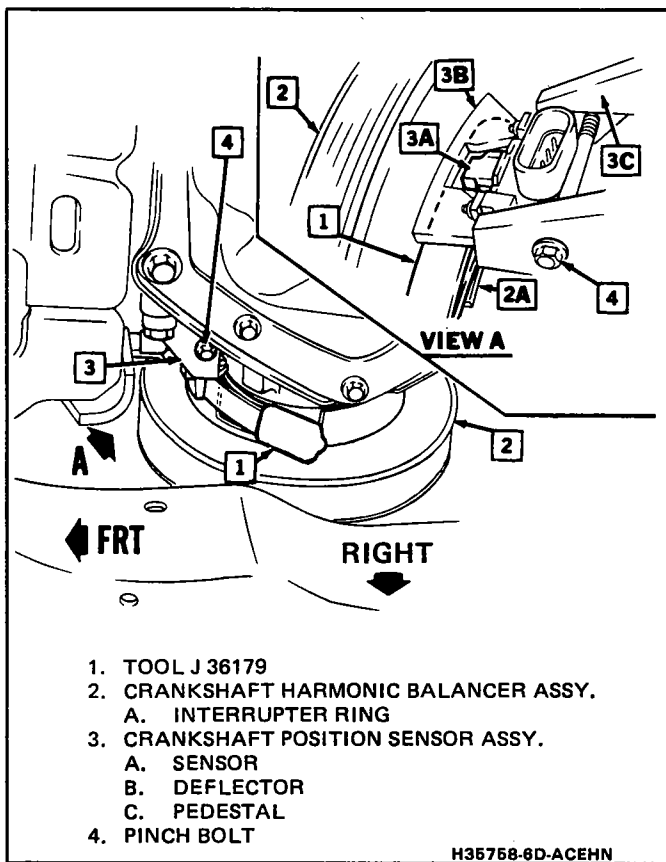

Figure 6D-33A Using Tool J-36179 - 3.0 & 3.8L, VIN B, L, & 3

5. Lower vehicle.
6. Install serpentine belt.
7. Connect negative battery cable.

### Set Ignition Timing

Timing specifications for each engine are listed in Section 6E and on the Vehicle Emissions Control Information Label on the radiator support. When using a timing light, connect an adapter between the No. 1 spark plug and the No. 1 spark plug wire, or use an inductive type pick-up. **Do not pierce the plug lead.** Once the insulation of the spark plug cable has been broken, voltage will jump to the nearest ground, and the spark plug will not fire properly. **Always follow the Emission Control Information Label procedures when adjusting timing.**

Start the engine and aim the timing light at the timing mark. The line on the balancer or pulley will line up at the timing mark. If a change is necessary, loosen the distributor hold-down clamp bolt at the base of the distributor. While observing the mark with the timing light, slightly rotate the distributor until the line indicates the correct timing. Tighten the hold-down bolt and re-check the timing.

Turn off the engine and remove the timing light. Reconnect the number one spark plug wire, if removed.

Some engines will incorporate a magnetic timing probe hole for use with special electronic timing equipment. Figure 6D-34 shows a typical magnetic probe hole. Consult manufacturer's instructions for use of this equipment.

### Installation

1. Install crankshaft sensor and bolts. Tighten to 30 N·m (22 ft. lb.).
2. Install sensor electrical connector.
3. Install crankshaft balancer and bolt. Tighten to 270 N·m (200 ft. lb.).
4. Attach inner fender splash shield.
5. Lower car.
6. Connect negative battery cable.

### Camshaft Sensor

#### A, C, H & E Series - VIN A, 3

1. Disconnect negative battery cable.
2. Remove serpentine belt.
3. Raise vehicle on hoist.
4. Remove inner fender splash shield.
5. Remove crankshaft balancer bolt.
6. Slide balancer toward right fender (A & E Series).
7. Remove crankshaft balancer (C, H & N Series).
8. Remove camshaft sensor bolt and sensor.
9. Remove sensor electrical connection.

**IMPORTANT:** When servicing requires that the "T" latch type wiring is disconnected, care must be taken to ensure proper reassembly of the harness connector and the "T" latch. Failure to do so may result in intermittent loss of operation.

1. Connect camshaft sensor electrical connector.
2. Install sensor and bolt. Tighten to 8.5 N·m (75 lbs. in.).
3. Install shaft balancer and bolt. Tighten to 270 N·m (200 lbs. ft.).
4. Attach fender splash shield.

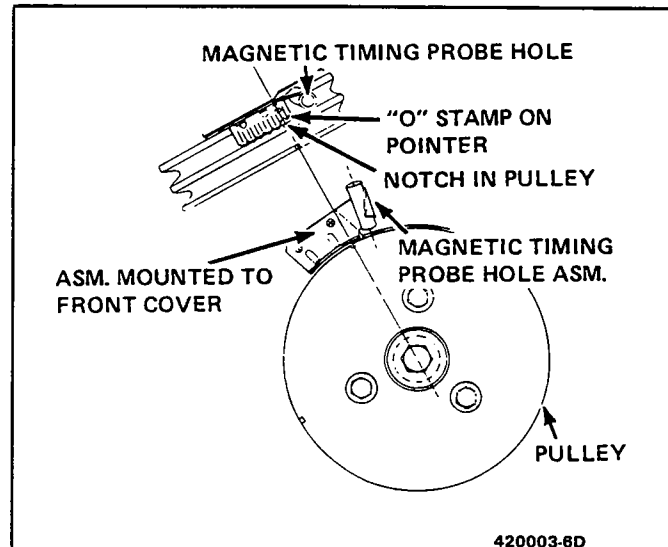

Figure 6D-34 Magnetic Timing Probe Hole

### Setting Ignition Timing-LD5

1. With engine at operating temperature, air cleaner installed and air conditioning off (if equipped), connect timing light or meter and verify "check engine" light is not on.
2. Disconnect distributor four wire electrical connector. "CHECK ENGINE" light will come on.
3. Set ignition timing to specification shown on EMISSION LABEL by loosening the distributor clamp bolt and rotating the distributor until the specification is obtained.
4. Tighten the distributor clamp bolt and recheck timing to make sure distributor was not moved during tightening of the bolt.
5. Reconnect distributor electrical connector.

- With engine off, momentarily disconnect battery to cancel any stored trouble codes.

### Setting Ignition Timing-LV2

- With engine **RUNNING** at operating temperature, choke fully open and air conditioning off (if equipped), ground the diagnostic terminal of the 12 terminal ALCL (Figure 6D-34A).
- With use of a timing light or meter, set timing at specified RPM, (shown on the EMISSION LABEL) by loosening the distributor clamp bolt and rotating the distributor until specified timing is obtained.
- Tighten the distributor clamp bolt and recheck timing to make sure distributor was not moved during tightening of the bolt.
- With the engine still running, unground the diagnostic terminal (if done before engine is shut off, no trouble codes will be stored).
- Make carburetor adjustments as required. Remove the plugs from any disconnected vacuum hoses and reconnect hoses.

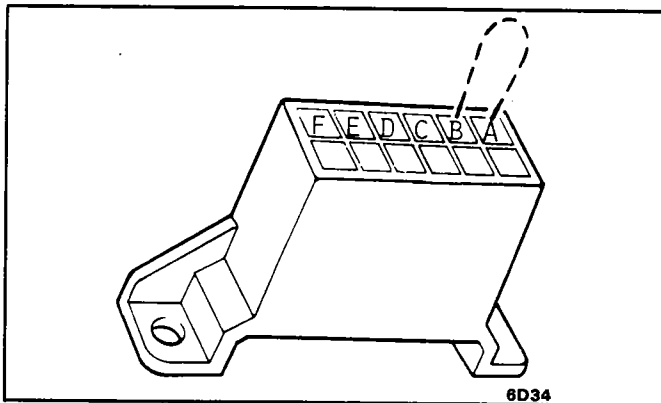

Figure 6D-34A Grounding the Diagnostic Lead

### Set Ignition Timing (2.0L-2.5L)

Refer to the Vehicle Emission Control Information Label located in the engine compartment. Follow **all instructions on the label**.

Ignition timing for this engine should be accomplished using the "averaging" method in which the timing of each cylinder can be brought into closer agreement with the base timing specification.

The "averaging" method involves the use of a double notched crankshaft pulley. When timing the engine, the coil wire, instead of the Number 1 plug wire, should be used to trigger the timing light. The notch for the No. 1 cylinder is scribed across all three edges of the double sheave pulley. Another notch located 180 degrees away from the No. 1 cylinder notch is scribed only across the center section of the pulley to make it distinguishable from the No. 1 cylinder notch. (See Figure 6D-35).

Since the trigger signal for the timing light is picked up at the coil wire, each spark firing results in a flash from the timing light. A slight jiggling of the timing notch may be apparent since each cylinder firing is being displayed. Refer to Figure 6D-36. Optimum timing of all cylinders is accomplished by centering the total apparent notch width about the correct timing specification.

The following procedure should be used to correctly time this engine. A magnetic timing P/U will not work and cannot be used with this procedure.

- On vehicles with electronic spark timing, it will be necessary to disconnect the four (4) terminal EST

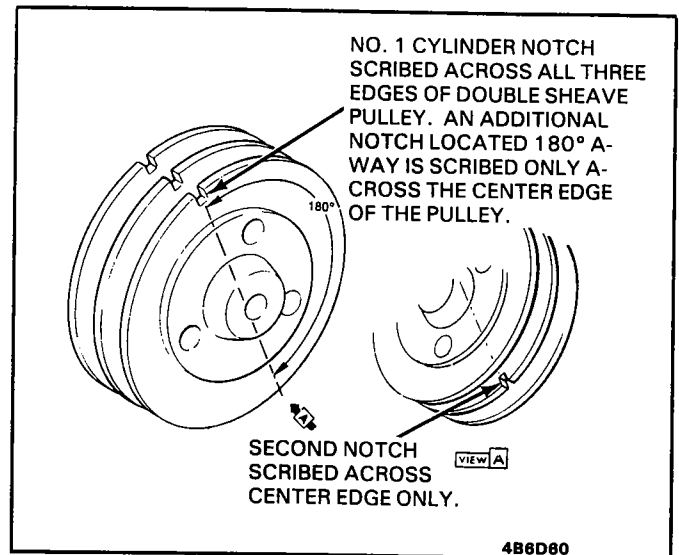

Figure 6D-35 Pulley Timing Notches

connector at the distributor to cause the engine to operate in the bypass timing mode.

- Follow manufacturer's instructions for connecting the timing light to the appropriate power source.
- Clamp timing light inductive pick-up around the **high tension coil wire**. It will be necessary to peel back the protective plastic cover on the wire in order to install the timing light inductive pickup.
- Loosen the distributor clamp nut slightly using Tool J-29828 so that the distributor may be rotated as necessary to adjust timing.
- Start the engine and aim the timing light at the timing tab. A slight jiggling of the pulley notch may appear due to the fact that each cylinder firing is being displayed. **The apparent notch width cannot be reduced by timing adjustment.**

Adjust the position of the distributor by rotating in the direction of advance or retard as necessary to center the total apparent notch width about the correct timing specification (see Figure 6D-36). This insures that the average cylinder timing is as close to the specification as possible.

When the adjustment is completed, shut off the engine and tighten down the distributor clamp nut, taking care not to disturb the position of the distributor as adjusted. The timing should be rechecked after tightening. Reinstall the distributor, four (4) terminal EST connector, and the protective plastic cover on the coil wire. Shut off engine. Remove the ECM "1" fuse to clear the trouble code memory. Replace fuse.

### Spark Plug Wires

Use care when removing spark plug wire boots from spark plugs. Use a special tool designed to remove spark plug boots, as many boots are hard to reach and pulling on the wire can cause damage to the system. If a puller is not available, twist the boot 1/2 turn before removing and pull on the **boot only** to remove the wire.

When replacing plug wires, route the wires correctly and through the proper retainers. Failure to route the wires properly can lead to chaffing, burning, cutting radio ignition noise, crossfiring of the plugs or shorting of the leads to ground.

Special care should be exercised when reinstalling spark plug boots to assure that the metal terminal within the boot is fully seated on the spark plug terminal and that the boot has not moved on the wire. If boot to wire movement has occurred, the boot will give a false visual impression of

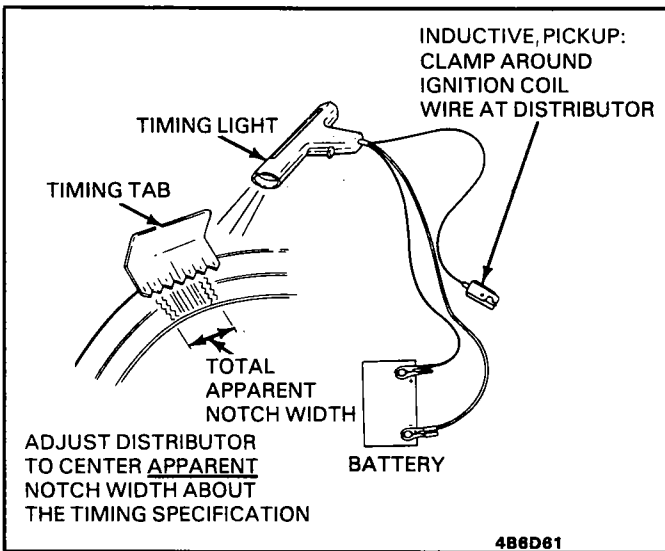

Figure 6D-36 Timing Light and Tab

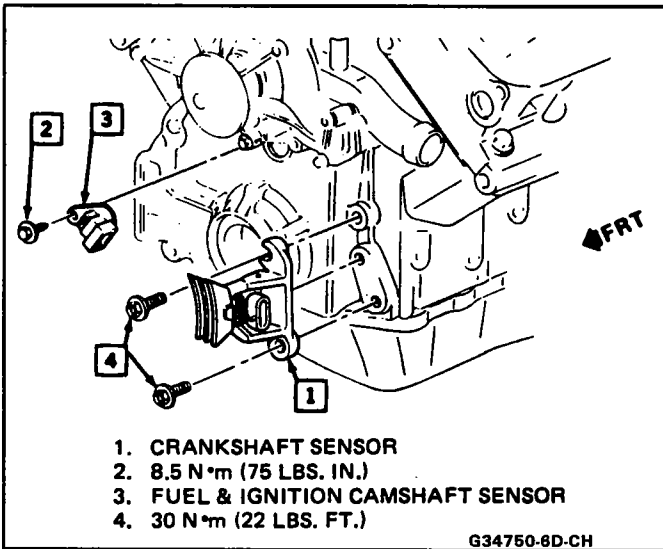
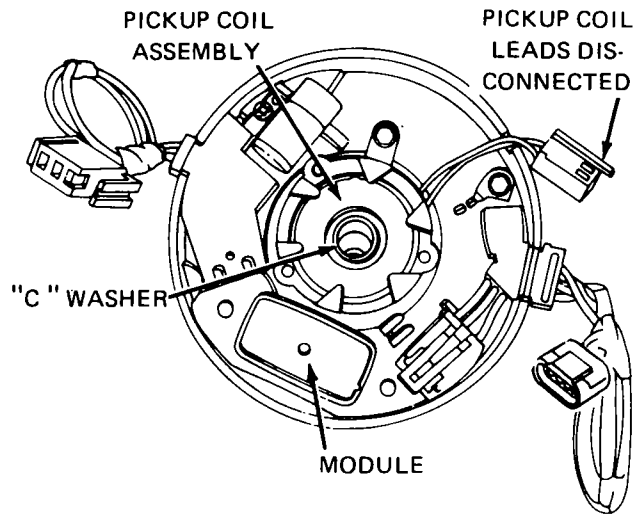

Figure 6D-36A Crankshaft and Camshaft Sensors

being fully seated. A good check to assure that boots have been properly assembled is to push sideways on the installed boots. If they have been correctly installed, a stiff boot, with only slight looseness will be noted. If the terminal has not been properly seated on the spark plug, only the resistance of the rubber boot will be felt when pushing sideways.

**ALUMINUM NON-MAGNETIC SHIELD REMOVED**



21. Remove three attaching screws and remove magnetic shield.

**MODULE REMOVED**

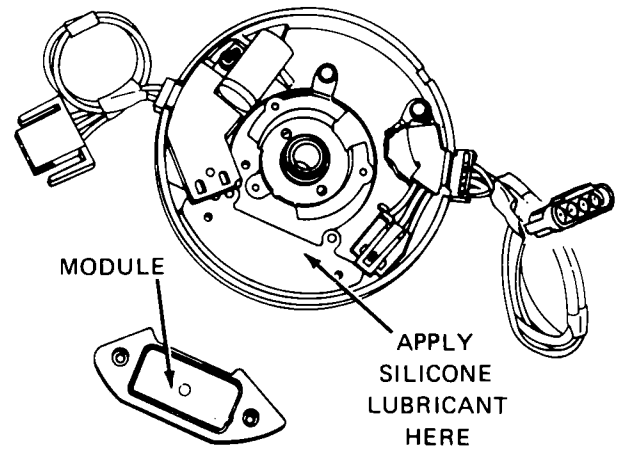

- 23. Remove two module attaching screws, and capacitor attaching screw. Lift module, capacitor and harness assembly from base.
- 24. Disconnect wiring harness from module.
- 25. Check module with an approved module tester.
- 26. Install module, wiring harness, and capacitor assembly. Use silicone lubricant on housing under module.

**PICKUP COIL REMOVED AND DISASSEMBLED**

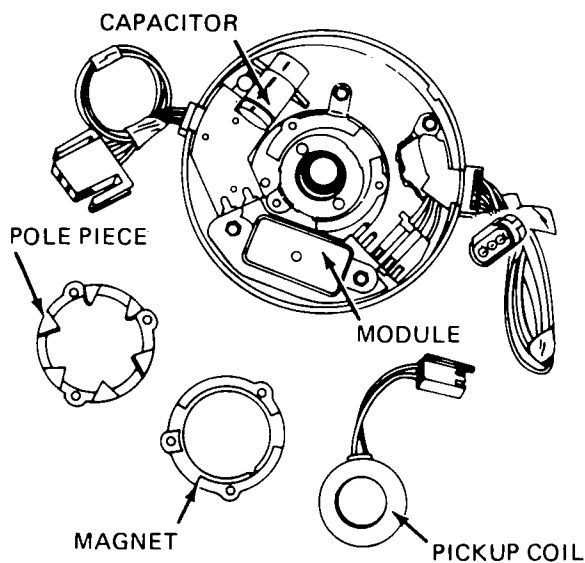

22. Remove retaining ring and remove pickup coil, magnet and pole piece.

**REASSEMBLY**

- 27. Assemble pickup and thin "C" washer.
- 28. Assemble shaft, gear parts and roll pin.
- 29. Spin shaft to insure that teeth do not touch.
- 30. Loosen, then re-tighten pickup coil teeth to eliminate contact.
- 31. Install rotor and cap.

Figure 6D-41 Dist. Disassembly Test & Reassembly (Coil in Cap) 3 of 3

# CRANKING SYSTEM

## CONTENTS

General Description .....	6D-36
Starter Motor .....	6D-36
Diagnosis .....	6D-36

Overrunning Clutch .....	6D-37
On-Car Service .....	6D-37
Starter Removal and Installation .....	6D-37

The cranking circuit consists of the battery, starting motor, ignition switch, and related electrical wiring. These components are connected electrically as shown in Figure 6D-42. Only the starting motor will be covered in this section.

### STARTER MOTOR

Enclosed shift lever cranking motors have the shift lever mechanism and the solenoid plunger enclosed in the drive housing protecting them from exposure to dirt, icing conditions and splash.

In the basic circuit shown in Figure 6D-42, the solenoid windings are energized when the switch is closed. The resulting plunger and shift lever movement causes the pinion to engage the engine flywheel ring gear and the solenoid main contacts to close, and cranking takes place. When the engine starts, pinion overrun protects the armature from excessive speed until the switch is opened, at which time the return spring causes the pinion to disengage. To prevent excessive overrun, the switch should be opened immediately when the engine starts.

### DIAGNOSIS

Before removing any unit in a cranking circuit for repair, the following checks should be made:

**Battery:** To determine the condition of the battery, follow the testing procedure outlined in the Battery Section.

**Wiring:** Inspect the wiring for damage. Inspect all connections to the cranking motor, solenoid, ignition switch and battery, including all ground connections. Clean and tighten all connections as required.

**Solenoid and Ignition Switch:** Inspect all switches to determine their condition.

**Starter Motor Noise:** To correct starter motor noise during starting, use the following procedure:

1. Refer to Figure 6D-43 to determine the problem.
2. If the complaint is similar to problem category 1 above, correction can be achieved by proper "shimming" as follows:
  - a. Check flywheel for damage - bent flywheel, unusual wear, etc.
  - b. Start engine and carefully touch outside diameter of rotating flywheel ring gear with chalk or crayon to show high point of tooth runout after engine is turned off. Turn engine off

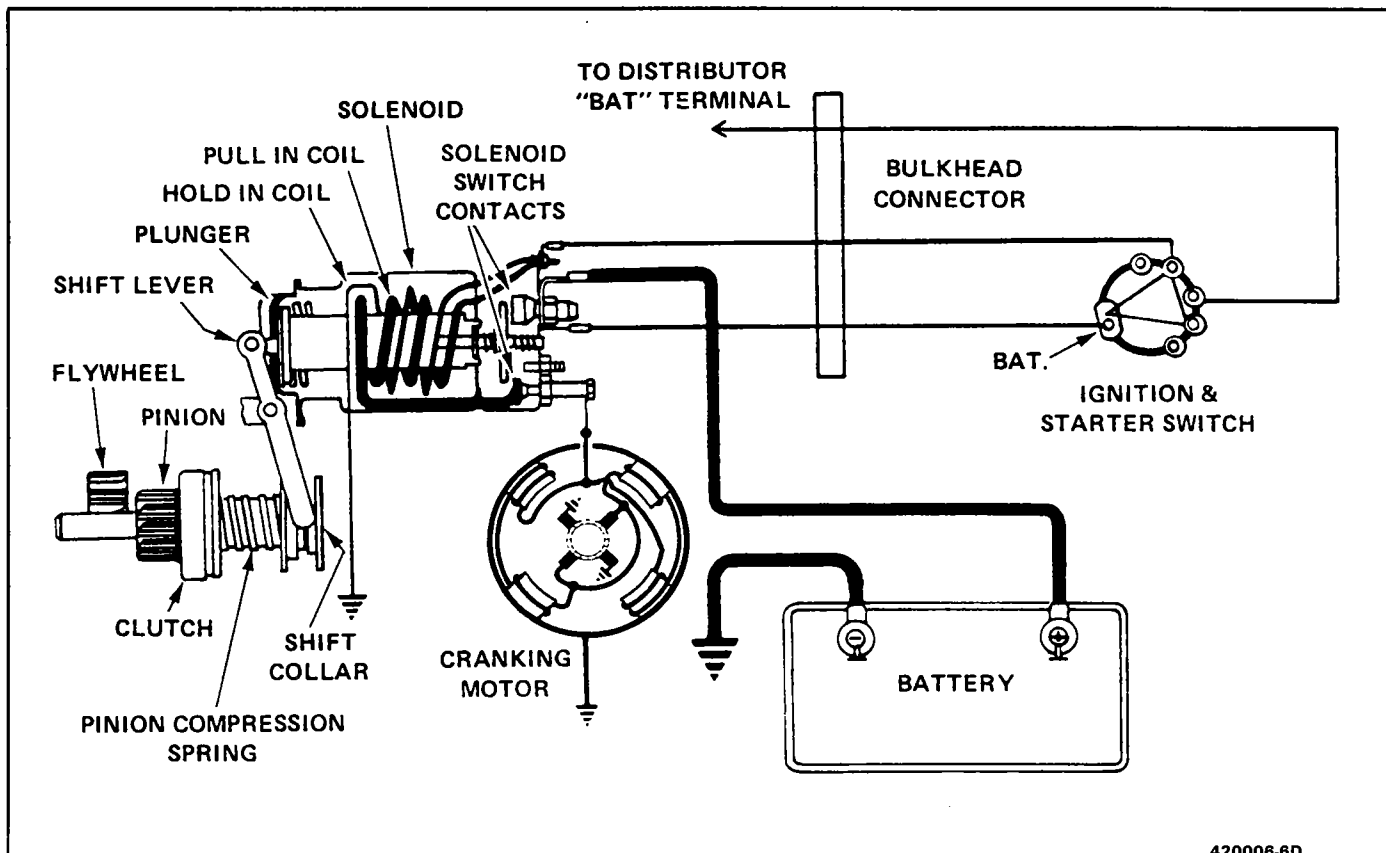

420006-6D

Figure 6D-42 Cranking Circuit



PROBLEM	CAUSE
1. HIGH PITCHED WHINE DURING CRANKING (BEFORE ENGINE FIRES) BUT ENGINE CRANKS AND FIRES OKAY.	DISTANCE TOO GREAT BETWEEN STARTER PINION AND FLYWHEEL.
2. HIGH PITCHED "WHINE" AFTER ENGINE FIRES, AS KEY IS BEING RELEASED. ENGINE CRANKS AND FIRES OKAY. THIS INTERMITTENT COMPLAINT IS OFTEN DIAGNOSED AS "STARTER HANG-IN" OR "SOLENOID WEAK."	DISTANCE TOO SMALL BETWEEN STARTER PINION AND FLYWHEEL. FLYWHEEL RUNOUT CONTRIBUTES TO THE INTERMITTENT NATURE.
3. A LOUD "WHOOOP" AFTER THE ENGINE FIRES BUT WHILE THE STARTER IS STILL HELD ENGAGED. SOUNDS LIKE A SIREN IF THE ENGINE IS REVVED WHILE STARTER IS ENGAGED.	MOST PROBABLE CAUSE IS A DEFECTIVE CLUTCH. A NEW CLUTCH WILL OFTEN CORRECT THIS PROBLEM.
4. A "RUMBLE", "GROWL" OR (IN SEVERE CASES) A "KNOCK" AS THE STARTER IS COASTING DOWN TO A STOP AFTER STARTING THE ENGINE.	MOST PROBABLE CAUSE IS A BENT OR UNBALANCED STARTER ARMATURE. A NEW ARMATURE WILL OFTEN CORRECT THIS PROBLEM.

420026-8D

Figure 6D-43 Starter Motor Noise Diagnosis

and rotate flywheel so that the marked teeth are in the area of the starter pinion gear.

- c. Disconnect negative battery cable to prevent cranking of engine.

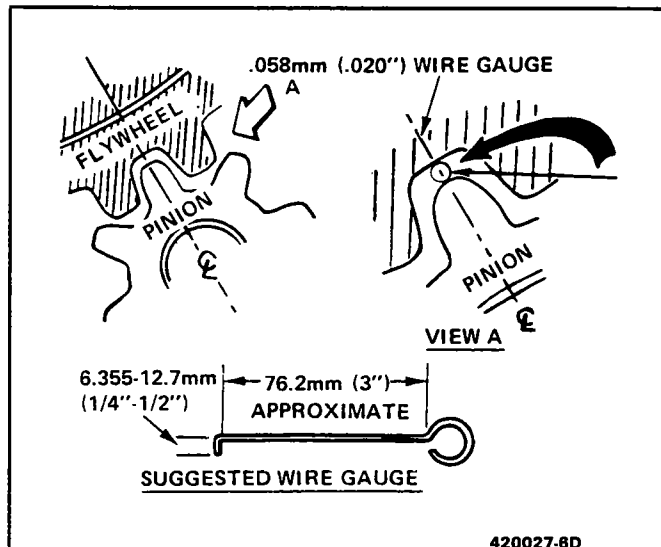

Figure 6D-44 Flywheel to Pinion Clearance

- d. Check pinion to flywheel clearance, as shown in Figure 6D-44, by using a wire gage of .5mm (.020") minimum thickness (or diameter). Center the pinion tooth between the flywheel teeth and gage, and not in the corners, where a misleading larger dimension may be observed. If the clearance is under this minimum, shimming the starter away from the flywheel is required.
- e. If the clearance is grossly over .5mm (.020") in the vicinity of 1.5mm (.060") or more, shimming the starter towards the flywheel is required. (This is generally the problem causing broken flywheel teeth or starter housings.) Shimming the starter towards the flywheel can be accomplished by shimming only the outboard starter mounting pad. A shim of .4mm (.015") thickness, at this location will decrease the clearance by approximately .3mm (.010").

If normal starter shims are not available, they can be improvised from plain washers or other suitable material.

**Starter Motor:** If the battery, wiring and switches are in satisfactory condition, and the engine is known to be functioning properly, remove the motor and follow the following test procedures.

Never operate the cranking motor more than 30 seconds at a time without pausing to allow it to cool for at

least two minutes. Overheating, caused by excessive cranking, will seriously damage the cranking motor.

A general diagnosis is covered in Figs. 6D-1 and 6D-2. Once a problem has been traced to the starter, proceed to disassembly test and reassembly in Figs. 6D-48 through 6D-58.

## OVERRUNNING CLUTCH-J SERIES

1. Test overrunning clutch action. The pinion should turn freely in the overrunning direction. Check pinion teeth to see that they have not been chipped, cracked, or excessively worn. Replace assembly if necessary. Badly chipped pinion teeth may indicate chipped teeth on the ring gear. This should be checked under such conditions and replaced if necessary.
2. Check the overrunning clutch for slipping by leaving the clutch attached to the armature, wrap the armature with a shop towel and clamp the armature in a vice. Using a 12-point deep socket and torque wrench, put the socket on the clutch and turn counterclockwise. The clutch should not slip up to 68 N·m (50 ft.lb.) of torque. If it does, replace the clutch.

## ON CAR SERVICE

Starting motors do not require lubrication except during overhaul.

When the motor is disassembled for any reason, lubricate as follows:

1. The roll type overrunning clutch requires no lubrication. However, the drive assembly should be wiped clean. **Do Not** clean in any degreasing tank or with grease dissolving solvents; this will dissolve the lubricant in the clutch mechanism. Use silicon grease General Electric CG321, Dow Corning 33 Medium or equivalent, on the shaft underneath the overrunning clutch assembly.
2. Avoid excessive lubrication.

## Starter-VIN L-N Series

During the 1987 model year, the 3.0 (VIN L) engine used in the N Series will be equipped with a Permanent Magnet Gear Reduction (PMGR) starter. Initially the PMGR starter will only be serviced as a remanufactured (exchange) assembly. Refer to the WDDGM Service Parts Information Bulletin for more information. Repair procedures will be printed later.

## Starter-C-H-N Series

### Remove

1. Disconnect negative battery lead at battery.

2. Raise car on hoist.
3. Remove starter splash shields and braces which may be in way.
4. Remove the two starter motor-to-engine bolts, then lower the starter.
5. Remove the solenoid wires and battery cable, then remove starter.

**Install**

1. Holding starter motor up attach solenoid wires and battery cable.
2. Secure starter motor to engine two bolts previously removed, and ensure that any shims previously removed are replaced.
3. Replace starter splash shields and braces which may have been removed.
4. Lower car.
5. Connect negative battery lead at battery.

**Remove and Install A Series**

Use the following procedure to remove the starter:

1. Disconnect negative battery lead at battery.
2. From beneath the car, remove three (3) dust cover bolts and pull dust cover back to expose front starter bolt.
3. Remove front starter motor to engine bolt.
4. Pull rear of dust cover backward enough to remove rear starter bolt.
5. Push dust cover back into place and pull starter back and out.
6. Remove solenoid wires and battery cable, and remove starter. To install, reverse the above procedure. Replace any shims that were removed.

**Solenoid****Remove and Install**

Use the following procedure to remove the solenoid from the starter:

1. Disconnect field strap.
2. Remove solenoid to drive housing attaching screws, motor terminal bolt, and remove solenoid by twisting.
3. Install by reversing above procedures.

**Remove and Install****Starter J Series**

Use the following procedure to remove the starter.

1. Disconnect negative battery lead at battery.
2. From beneath the car, remove solenoid wires and battery cable.
3. Remove rear motor support bracket.
4. Remove A/C compressor support rod (where equipped).
5. Remove two starter motor to engine bolts, and remove starter.
6. To replace, reverse the above procedure. Replace any shims that were removed.

**Manual Transmission-Eng. Code "K"****Remove and Install**

1. Disconnect negative battery cable at battery.
2. Remove upper starter to engine block bolt.
3. Raise car on a hoist.
4. To remove rear starter brace, remove bolt from engine block and nut and washer from starter.

5. Remove lower starter to engine block bolt.
6. Remove positive battery cable and solenoid wires and lower starter.
7. To install starter, reverse removal procedure.

**Automatic Transmission-Engine Code "K"****Remove and Install**

1. Disconnect negative battery cables.
2. Remove air cleaner.
3. Remove lower starter to engine block bolt.
4. To remove rear starter brace, remove bolt from engine block and nut from starter.
5. Remove positive cable and solenoid wires.
6. Remove starter to engine block bolt.
7. Raise car on hoist.
8. Disconnect speedometer cable.
9. Push shift cable up, guide starter armature end down between stabilizer bar and engine. (It may be necessary to pry engine block forward.)
10. To install starter, reverse removal procedure.

**Remove and Install-Engine Code "M"**

1. Disconnect negative battery cable at battery.
2. Remove intake manifold support brace.
3. Disconnect wiring to coil and M.A.T. connection in intake manifold.
4. Remove upper starter bolt.
5. Remove bolt from engine harness brackets to intake manifold.
6. Raise vehicle.
7. Remove transmission strut.
8. Remove fuel line to support bracket bolt and loosen fuel lines at least 1/2 turn to gain access to the starter.
9. Remove fuel line support bracket.
10. Remove rear starter bracket, careful not to bend turbo oil feed pipe.
11. Disconnect wiring to solenoid.
12. Remove lower starter bolt and starter.
13. To replace, reverse the above procedure.

**SOLENOID**

Use the following procedure to remove the solenoid from the starter:

1. Disconnect field strap.
2. Remove solenoid to drive housing attaching screws, motor terminal bolt, and remove solenoid by twisting.
3. Install by reversing above procedure.

**Remove and Install (B & G Series Starter)**

Use the following procedure to remove the starter:

1. Disconnect negative battery lead at battery.
2. Raise car.
3. Remove starter braces, shields, etc., that may be in the way.
4. Remove two starter motor to engine bolts, and allow starter to drop down.
5. Remove solenoid wires and battery cable and remove starter.
6. To replace, reverse the above procedure. Insure that any shims removed are replaced.

**Remove and Install (E Series)**

1. Disconnect negative battery cable.
2. Raise car on hoist.

3. Remove starter spalsh shield (2 bolts).
4. Remove two bolts securing starter to engine block.
5. Remove starter solenoid wires and battery cable.
6. To replace, reverse the above procedure and insure that any shims removed are replaced.

**UNIT REPAIR**

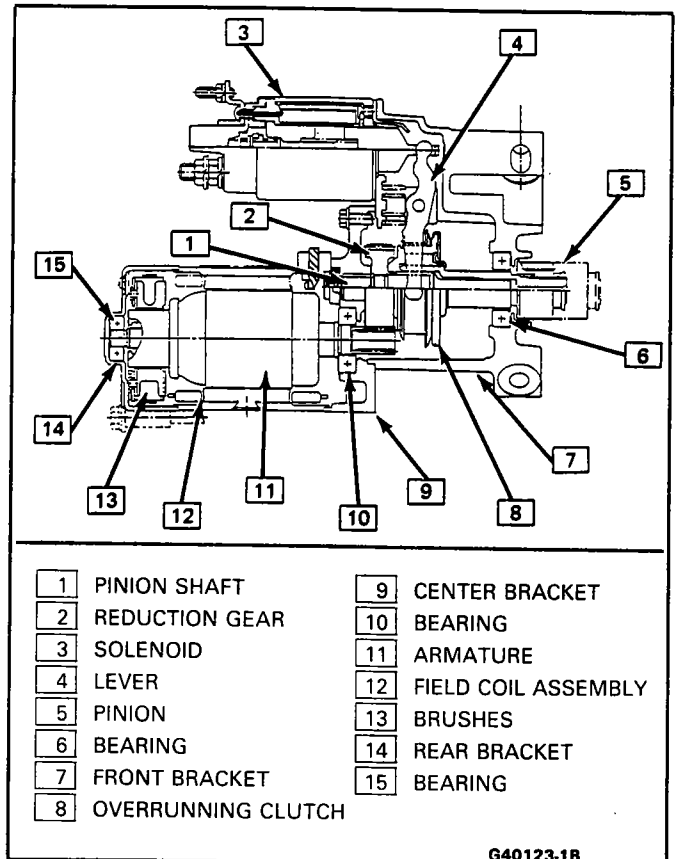

Figure 6D-45 Cross Section "E" Series Starting Motor

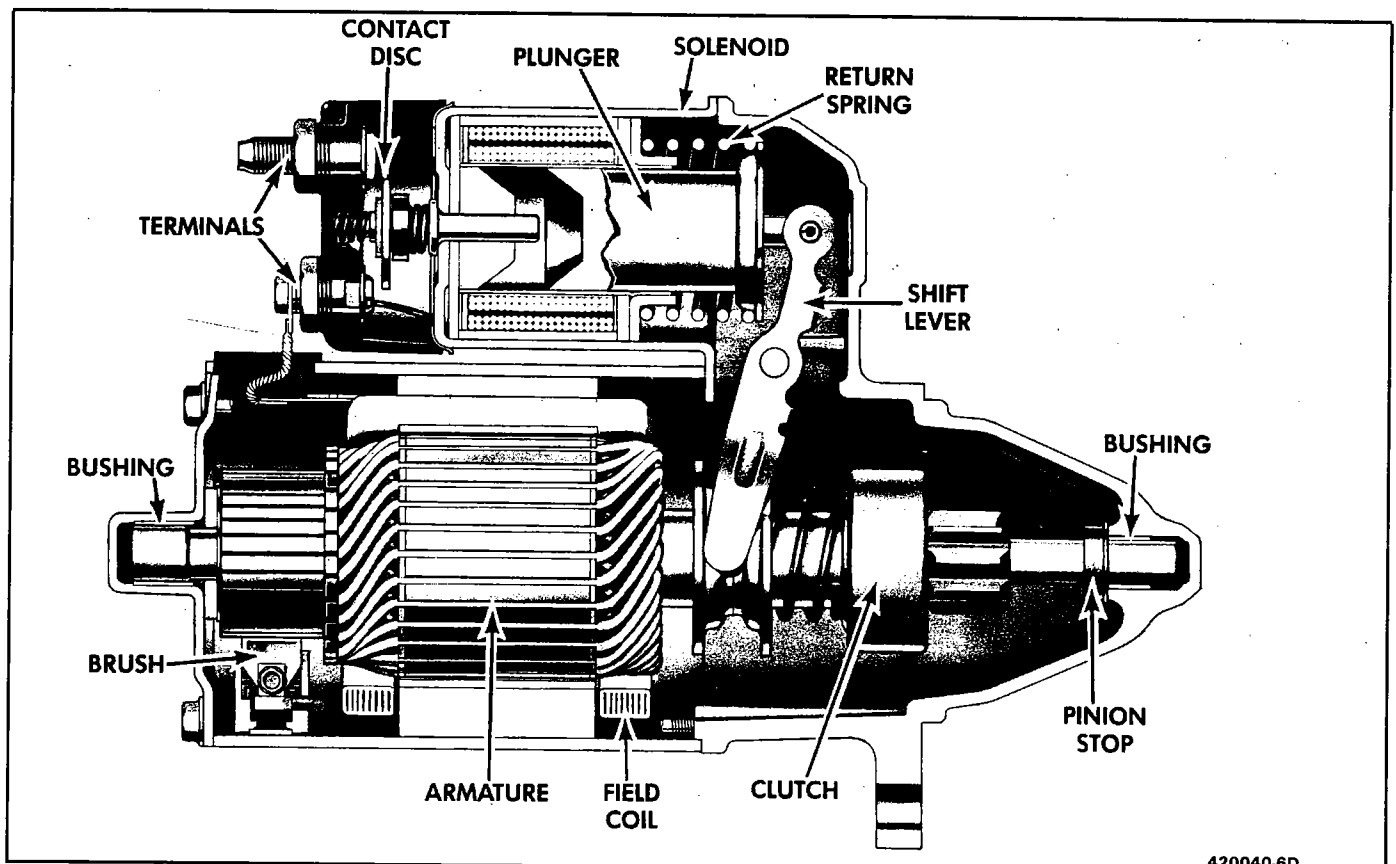
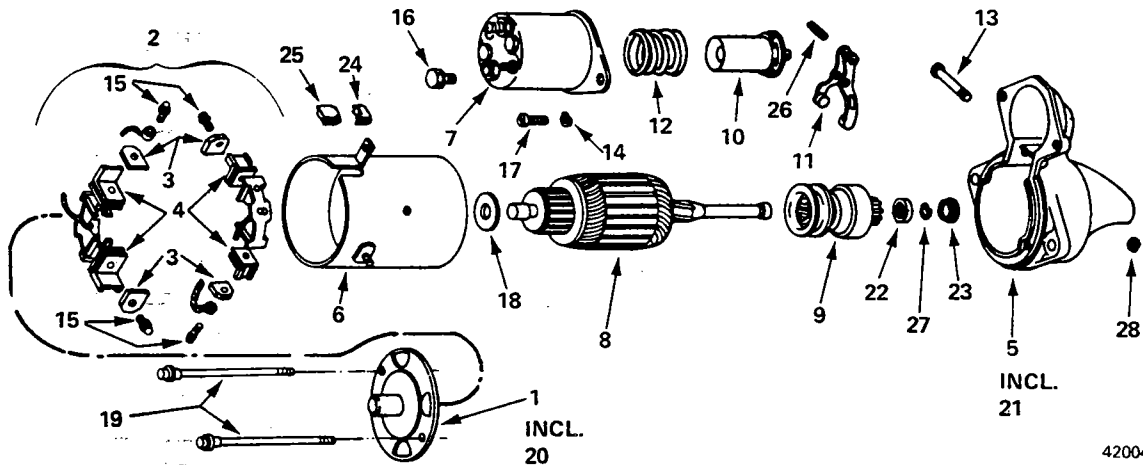

Figure 6D-46 Cross Section of 5MT Starting Motor

420040-6D



420041-6D

- 1. FRAME—COMMUTATOR END
- 2. BRUSH AND HOLDER PKG.
- 3. BRUSH
- 4. BRUSH HOLDER
- 5. HOUSING—DRIVE END
- 6. FRAME AND FIELD ASM.
- 7. SOLENOID SWITCH
- 8. ARMATURE
- 9. DRIVE ASM.

- 10. PLUNGER
- 11. SHIFT LEVER
- 12. PLUNGER RETURN SPRINGER
- 13. SHIFT LEVER SHAFT
- 14. LOCK WASHER
- 15. SCREW—BRUSH ATTACHING
- 16. SCREW—FIELD LEAD TO SWITCH
- 17. SCREW—SWITCH ATTACHING
- 18. WASHER—BRAKE

- 19. THRU BOLT
- 20. BUSHING—COMMUTATOR END
- 21. BUSHING—DRIVE END
- 22. PINION STOP COLLAR
- 23. THRUST COLLAR
- 24. GROMMET
- 25. GROMMET
- 26. PLUNGER PIN
- 27. PINION STOP RETAINER RING
- 28. LEVER SHAFT RETAINING RING

420041-6D

Figure 6D-47 5MT Starting Motor - Exploded View

## 5MT AND 10MT STARTER MOTORS DISASSEMBLY, TEST AND REASSEMBLY (STARTER REMOVED FROM ENGINE)

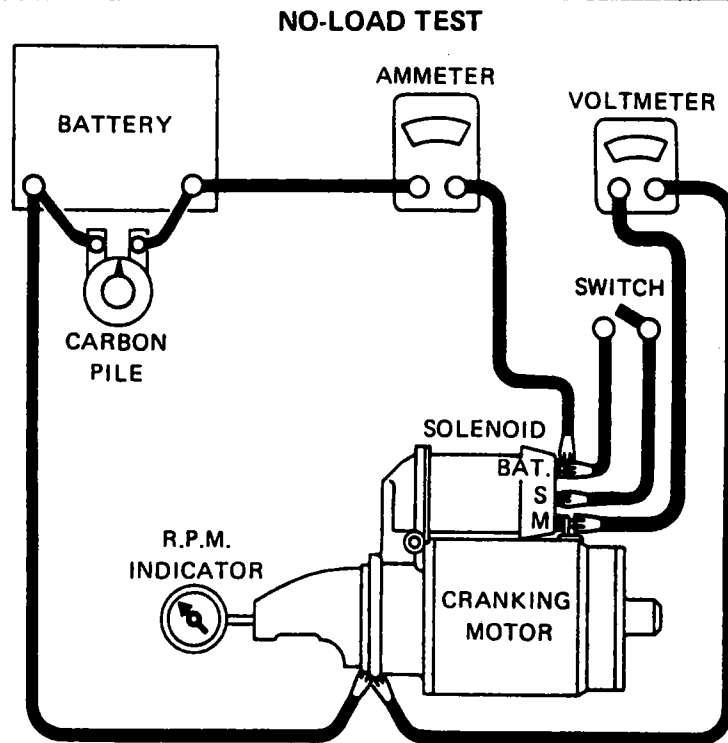

With the starter motor removed from the engine, the pinion should be checked for freedom of operation by turning it on the screw shaft. The armature should be checked for freedom of rotation by prying the pinion with a screwdriver. If the armature does not turn freely, the motor should be disassembled immediately. However, if the armature does rotate freely, the motor should be given a no-load test before disassembly.

Make connections as shown. Close the switch and compare the RPM, current, and voltage readings with the specifications. If the specified current draw does not include the solenoid, deduct from the ammeter reading the specified current draw of the solenoid hold-in winding. Make disconnections only with the switch open. Use the test results as follows:

**1. Rated current draw and no-load speed indicates normal condition of the starter motor.**

**2. Low free speed and high current draw indicates:**

- Too much friction — tight, dirty, or worn bearings, bent armature shaft allowing armature to drag.
- Shorted armature. This can be further checked on a growler after disassembly.
- Grounded armature or fields. Check further after disassembly.

**3. Failure to operate with high current draw indicates:**

- A direct ground in the terminal or fields.
- "Frozen" bearings (this should have been determined by turning the armature by hand).

**4. Failure to operate with no current draw indicates:**

- Open field circuit. This can be checked after disassembly by inspecting internal connections and tracing circuit with a test lamp.
- Open armature coils. Inspect the commutator for badly burned bars after disassembly.
- Broken brush springs, worn brushes, high insulation between the commutator bars or other causes which would prevent good contact between the brushes and commutator.

**5. Low no-load speed and low current draw indicates:**

- High internal resistance due to poor connections, defective leads, dirty commutator and causes listed under Number 4.

**6. High free speed and high current draw usually indicate shorted fields. If shorted fields are suspected, replace the field coil assembly. Also check for shorted armature, using a growler.**

STARTER DISASSEMBLY

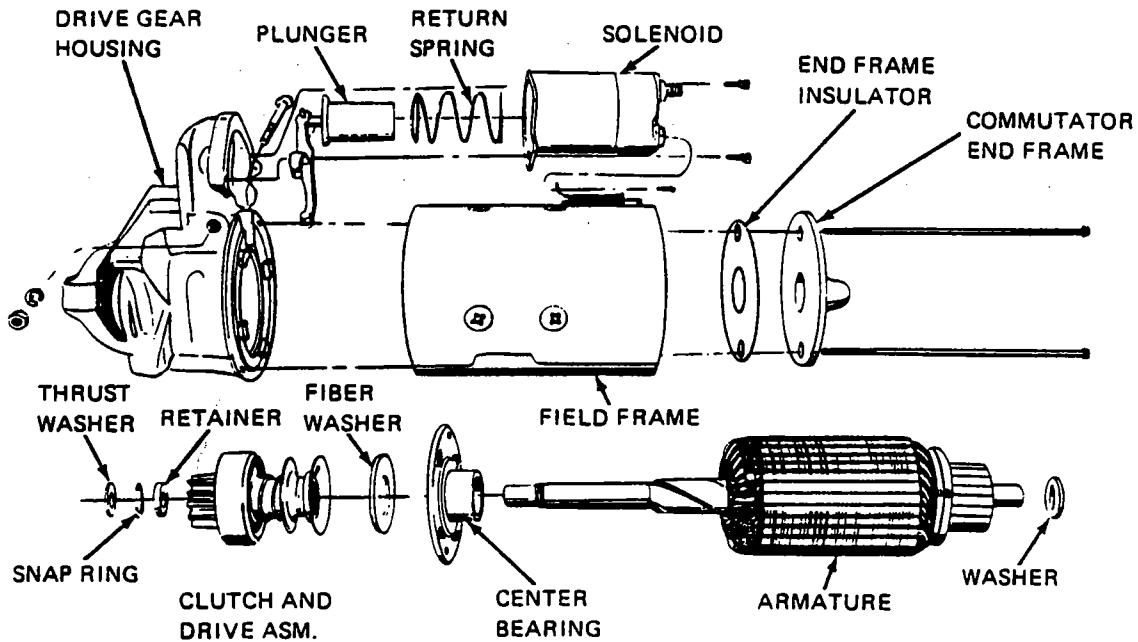

7. Remove screw from field coil connector and solenoid mounting screws. Rotate solenoid 90° and remove along with plunger return spring. Solenoid may now be serviced without further starter disassembly at this time.

8. Remove 2 through bolt, then remove commutator end frame (diesel only, remove insulator) and washer.

9. Remove field frame assembly from drive gear housing. (On diesel starter, armature remains in drive end frame.)

SHIFT LEVER AND PLUNGER REMOVAL

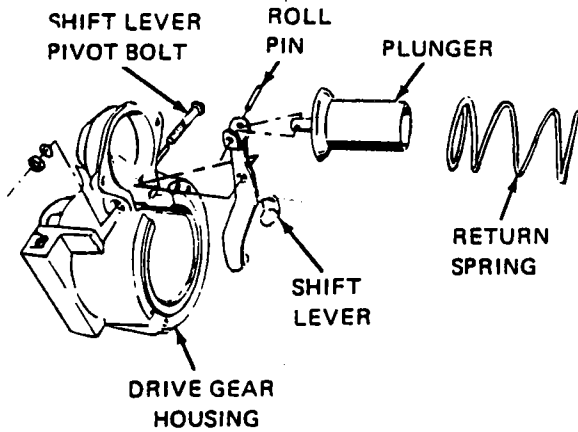

Steps 10 and 11 are required only on diesel starters.

10. Remove shift lever pivot bolt.

11. Remove drive gear housing from armature shaft. Shift lever and plunger assembly will now fall away from starter clutch.

REMOVE DRIVE ASSEMBLY FROM SHAFT

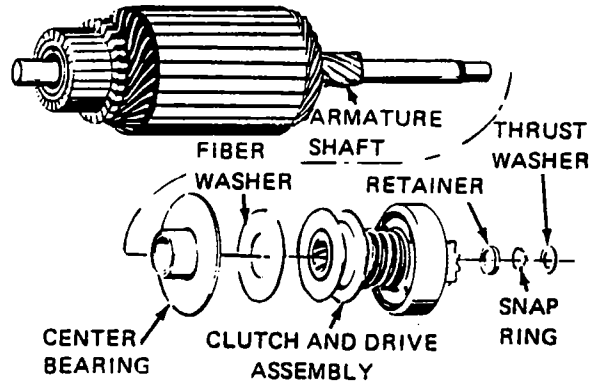

12. If necessary to remove overrunning clutch from armature shaft, proceed as follows:

- a. Remove thrust washer or collar from armature shaft.
- b. Slide a 5/8" deep socket or piece of pipe of suitable size over shaft against retainer as a driving tool. Tap tool to move retainer off snap ring.
- c. Remove snap ring from groove in shaft. If snap ring is distorted, it will be necessary to use a new one on reassembly.
- d. Remove retainer, clutch assembly (also fiber washer and center bearing on diesel) from armature shaft.

13. The shift lever and plunger may be disassembled at this time by removing the roll pin.

Figure 6D-49 Starter Motor Disassembly, Test, and Reassembly 2 of 6

### REPLACE BRUSH HOLDER (STANDARD STARTER) (SMALL 5MT STARTER)

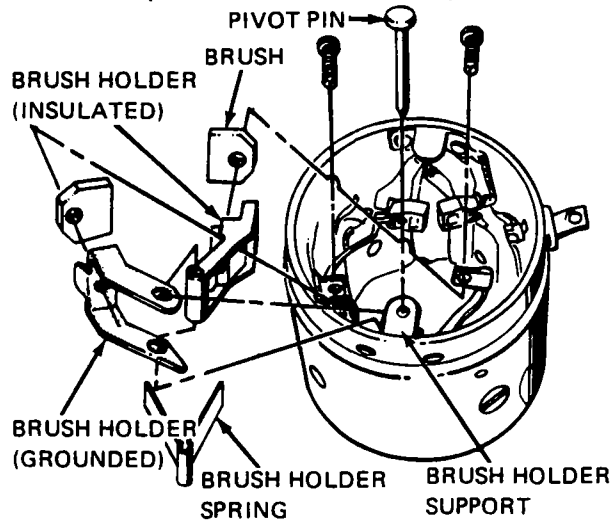

14. If necessary to replace brush holder parts, proceed as follows:
- Remove brush holder pivot pin which positions one insulated and one grounded brush.
  - Remove brush spring.
  - Replace brushes as necessary.

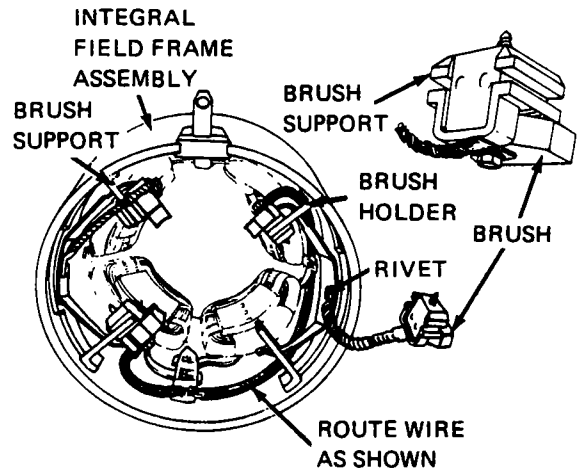

- Remove brush holder from brush support.
- Remove screw from brush holder and separate brush and holder.
- Inspect brush holder for wear or damage.
- Replace brushes and/or holders as necessary.

## CLEANING INSPECTION AND TESTS

### TESTING SHUNT COIL FOR OPEN

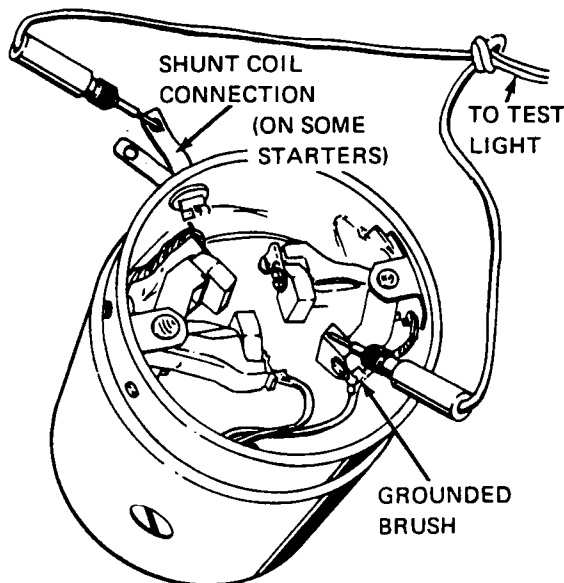

15. Clean all starting motor parts, but **DO NOT USE GREASE DISSOLVING SOLVENTS FOR CLEANING THE OVERRUNNING CLUTCH, ARMATURE, AND FIELD COILS.** solvent would dissolve the grease packed in the clutch and would damage armature and field coil insulation.

16. Inspect armature commutator, shaft and bushings, overrunning clutch pinion, brushes and springs for discoloration, damage or wear. Replace as required.

17. Check fit of armature shaft in bushing in drive housing. Shaft should fit snugly in the bushing. If the bushing is worn, it should be replaced.

18. Inspect armature commutator. If commutator is rough, it should be turned down. Do not undercut or turn to less than 1.650" O.D. Do not turn out-of-round commutators. Inspect the points where the armature conductors join the commutator bars to make sure they have a good connection. A burned commutator bar is usually evidence of a poor connection.

19. If test equipment is available:

- Check the armature for short circuits by placing on growler and holding hack saw blade over armature core while armature is rotated. If saw blade vibrates, armature is shorted. Recheck after cleaning between the commutator bars. If saw blade still vibrates, replace the armature.

- Using a test lamp, place one lead on the shunt coil terminal and connect the other lead to a ground brush. This test should be made from both ground brushes to insure continuity through both brushes and leads. If the lamp fails to light, the field coil is open and will require replacement.

**TESTING SERIES COIL FOR OPEN**

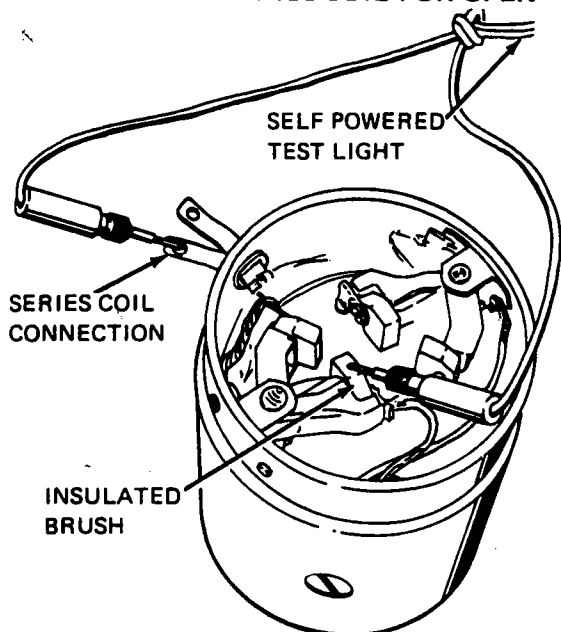

c. Using a test lamp, place one lead on the series coil terminal and the other lead on the insulated brush. If the lamp fails to light, the series coil is open and will require repair or replacement. This test should be made from each insulated brush to check brush and lead continuity.

**TESTING SERIES COIL FOR GROUND**

THESE TWO TERMINALS MUST BE SEPARATED AND NOT TOUCHING A GROUND DURING TEST

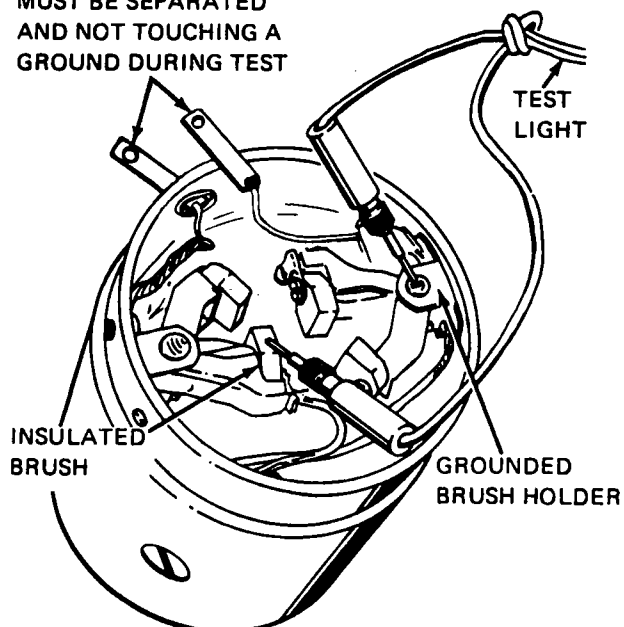

d. On starters with shunt coil, separate series and shunt coil strap terminals during this test. Do not let strap terminals touch case or other ground. Using a test lamp place one lead on the grounded brush holder and the other lead on either insulated brush. If the lamp lights, a grounded series coil is indicated and must be repaired or replaced.

**TESTING SOLENOID WINDINGS**

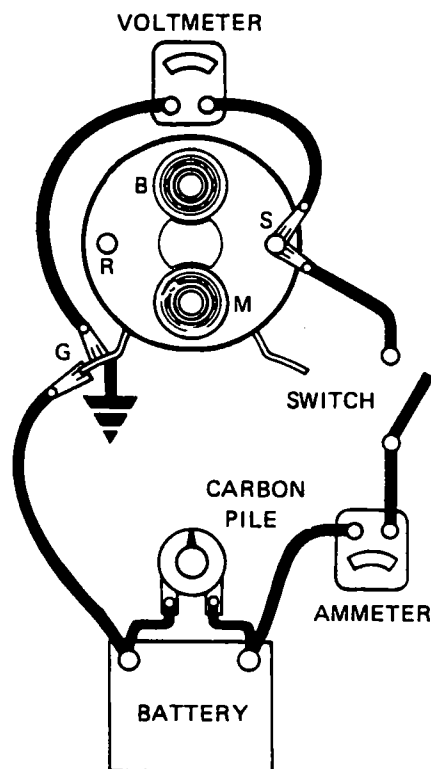

e. Check the current draw of the solenoid winding as follows:

If solenoid is not removed from starting motor, the connector strap terminals must be removed from the terminal on the solenoid before making these tests. Complete tests in a minimum of time to prevent overheating of the solenoid.

To check hold-in winding, connect an ammeter in series with 12-volt battery and the "switch" terminal on the solenoid. Connect a voltmeter to the "switch" terminal and to ground. Connect carbon pile across battery. Adjust the voltage to 10 volts and note the ammeter reading. It should be 14.5 to 16.5 amperes for all starting motors.

To check both windings, connect as for previous test. Ground the solenoid motor terminal. Adjust the voltage to 10 volts and note the ammeter reading. It should be 41 to 47 amperes for all starting motors.

NOTE: Current will decrease as windings heat up.

Current draw readings that are over specifications indicate shorted turns or a ground in the windings of the solenoid and the solenoid should be replaced. Current draw readings that are under specifications indicate excessive resistance. No reading indicates an open circuit. Check connections then replace solenoid if necessary.



## SOLENOID SWITCH DISASSEMBLY

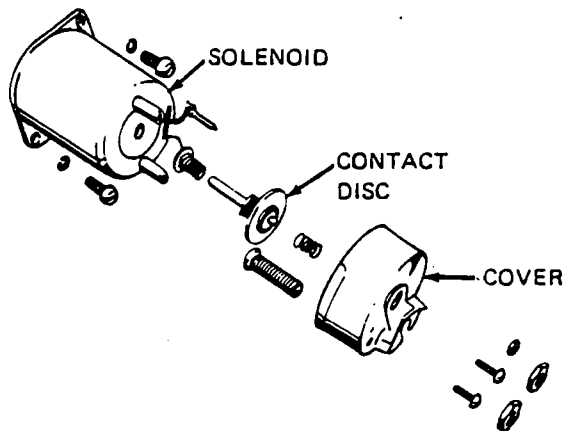

f. The starter solenoid switch is serviced as an assembly. The cover can be removed to inspect the contacts and contact disc if necessary.

## STARTER ASSEMBLY

## INSTALLING RETAINER, WASHER AND RING

20. Assemble the armature and clutch as follows:
  - a. Lubricate drive end of armature shaft with lubricant 1960954 or equivalent.
  - b. Install center bearing (diesel starters) with bearing toward the armature winding. Then install the fiber washer on the armature shaft.
  - c. Slide clutch assembly onto armature shaft with pinion away from armature.
  - d. Slide retainer onto shaft with cupped side facing the end of shaft.
  - e. Install snap ring into groove on armature shaft.
  - f. Install thrust washer on shaft.
  - g. Position retainer and thrust washer with snap ring in between. Using two pliers, grip retainer and thrust washer or collar and squeeze until snap ring is forced into retainer and is held securely in groove in armature shaft.
21. Lubricate drive gear housing bushing with lubricant 1960954 or equivalent.
22. Engage shift lever yoke with clutch and slide complete assembly into drive gear housing.
 

On non-diesel starters the shift lever may be installed in drive gear housing first.
23. Install the shift lever pivot bolt. Tighten securely.
24. Install solenoid assembly.
25. Apply sealer, No. 1050026 or equivalent to solenoid flange where field frame contacts it.

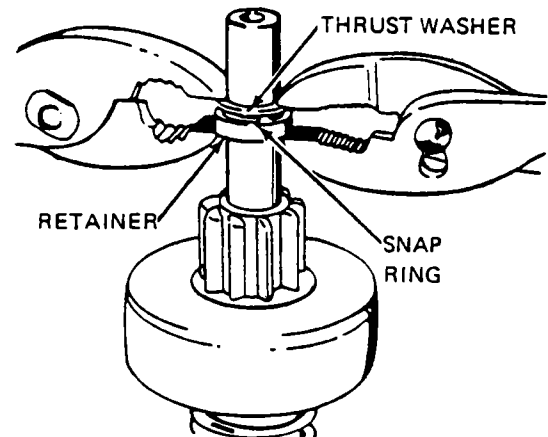

26. Position field frame against drive gear housing on alignment pin using care to prevent damage to brushes.
27. Lubricate commutator end-frame bushing with lubricant 1960954 or equivalent.
28. Install washer on armature shaft and slide end frame onto shaft, then install and tighten through-bolts. On diesel starter, install insulator and then end frame onto shaft. Then install through bolts, making sure they pass through bolt holes in insulator.
29. Connect the field coil connector to the solenoid terminal.
30. Check pinion clearance as outlined under PINION CLEARANCE.

### CHECKING PINION CLEARANCE

PRESS ON CLUTCH TO REMOVE SLACK

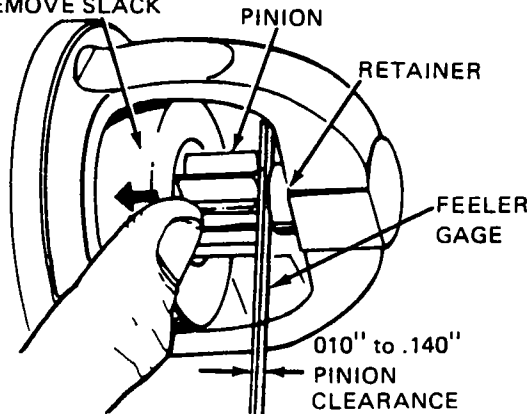

When the starter motor has been disassembled or the solenoid has been replaced, it is necessary to check the pinion clearance. Pinion clearance must be correct to prevent the buttons on the shift lever yoke from rubbing on the clutch collar during cranking.

31. Disconnect the motor field coil connector from the solenoid motor terminal and insulate it carefully.

32. Connect one 12 volt battery lead to the solenoid switch terminal and the other to the starter frame.

33. Flash a jumper lead momentarily from the solenoid motor terminal to the starter frame. This will shift the pinion into cranking position and it will remain so until the battery is disconnected.

34. Push the pinion back as far as possible to take up any movement, and check the clearance with a feeler gage. The clearance should be .010" to .140".

Means for adjusting pinion clearance is not provided on the starter motor. If the clearance does not fall within limits, check for improper installation and replace all worn parts.

420047-6D

Figure 6D-53 Starter Motor Disassembly, Test, and Reassembly 6 of 6

## STARTER DIAGNOSIS AND OVERHAUL

### NO-LOAD TEST

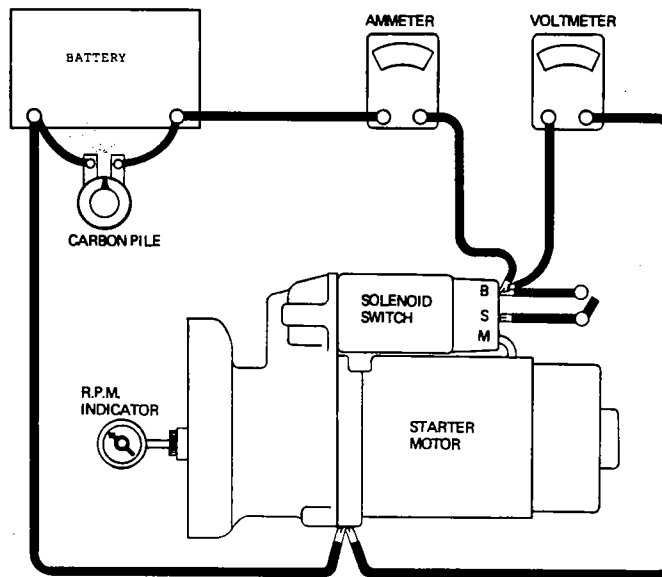

With the starter motor removed from the engine, to determine the cause of abnormal operation, the starter should be given a no-load test before disassembly.

Make connections as shown. Close the switch and compare the RPM, current and voltage readings with the Service Specifications. Make disconnections only with the switch open.

Use the test results as follows:

1. **Rated current draw and no-load speed indicates normal condition of the starter.**

2. **Low free speed and high current draw indicates:**

- Too much friction-tight, dirty or worn bearings.
- Shorted armature. This can be further checked on a growler after disassembly.
- Grounded armature or field. Check further after disassembly.

3. **Failure to operate with high current draw indicates:**

- A direct ground in the terminal or fields.
- "Frozen" bearings.

4. **Failure to operate with no current draw indicates:**

- Open field circuit. This can be checked after disassembly by inspecting internal connections and tracing circuit with a test lamp.
- Open armature coils. Inspect the commutator for badly burned bars after disassembly.
- Broken brush springs. Worn brushes, extreme dirty commutator or other causes which would prevent good contact between the brushes and commutator.
- Open circuit in the switch.

5. **Low no-load speed and low current draw indicates:**

- High internal resistance due to poor connections, defective leads, dirty commutator, burned contact points in the switch and causes listed under Number 4.

6. **High free speed and low current draw usually indicates shorted field. If shorted fields are suspected, replace them as a field frame assembly. Also check for shorted armature using a growler.**

G35178-6D-E-R1

Figure 6D-54 Starter Motor Diagnosis and Overhaul (1 of 7)

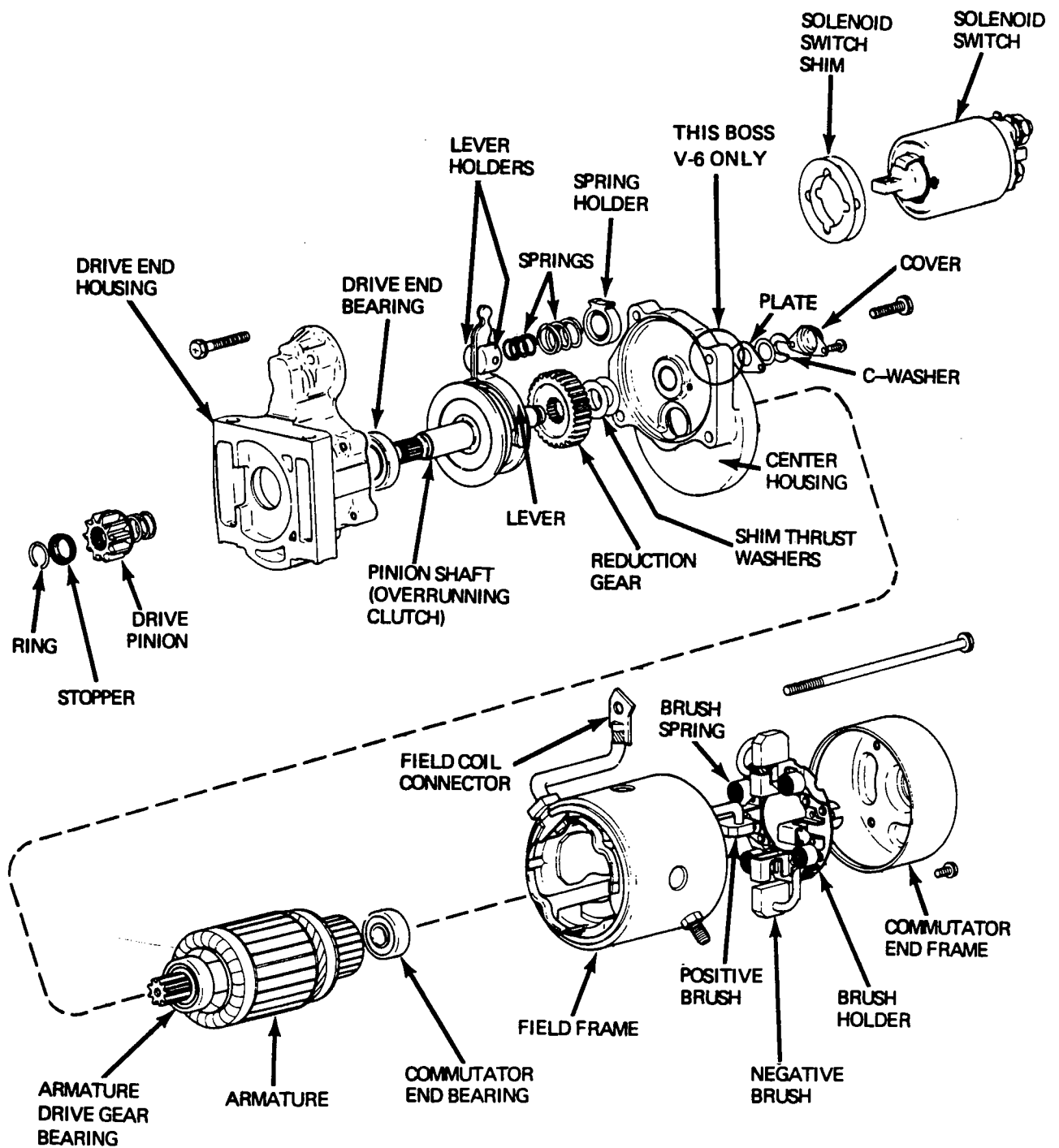
**STARTER DISASSEMBLY**

When repairing the starter, complete disassembly may not be required. However, in this section, the complete overhaul is covered step by step to provide detailed information on each operation.

7. Remove nut from field coil connector and (2) solenoid switch mounting screws. Remove solenoid switch assembly by pulling upward and forward. Some starters may have shims between the solenoid switch and drive end

housing. These shims are used to set drive pinion position. The solenoid switch may be serviced without further starter disassembly at this time.

8. Remove two through bolts and two brush holder retaining screws. Then remove commutator end frame from armature and bearing assembly.

9. Remove field frame assembly and armature from center housing.

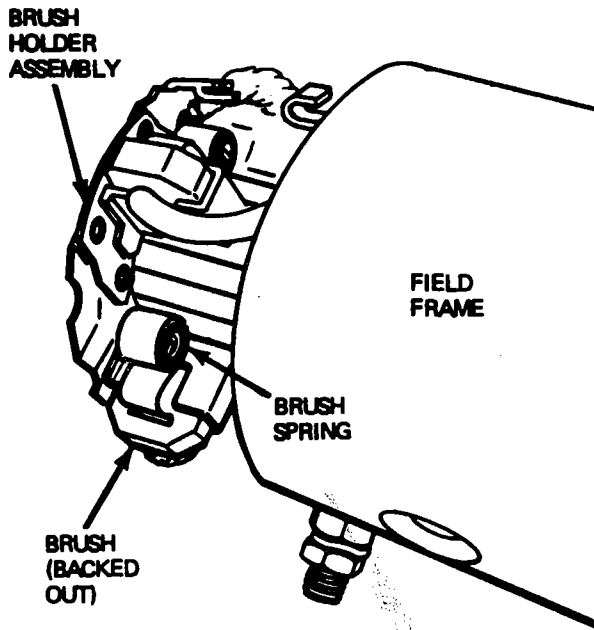

10. Pry back each brush spring so that each brush can be backed away from armature about 1/4". Then release spring to hold brushes in backed out position as shown. Then remove armature from field frame and brush holder.

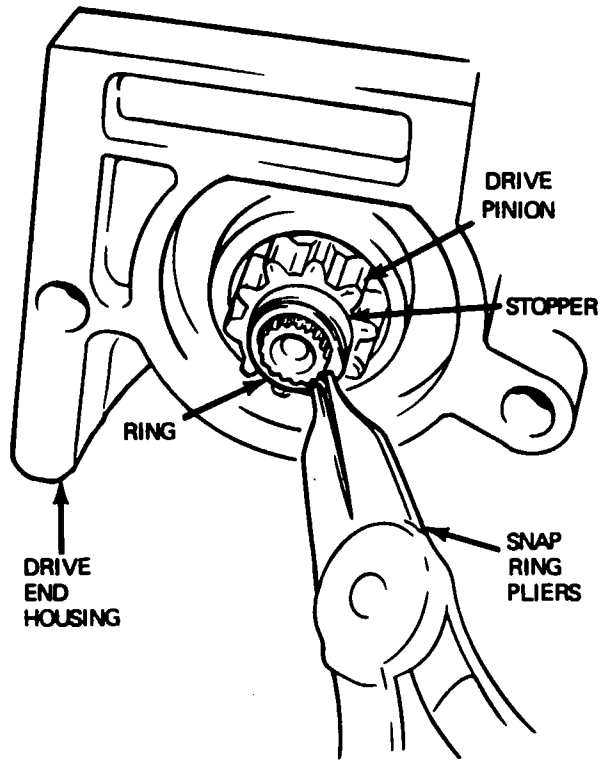

14. To remove drive pinion, proceed as follows:

a. Slide a 16mm (5/8") socket or piece of pipe of suitable size over shaft against stopper as a driving tool. Tap tool to move stopper off ring.

b. Remove ring from groove in shaft (shown above). If ring is distorted, it will be necessary to use a new one on reassembly.

c. Remove stopper and drive pinion.

15. Remove pinion shaft and lever assembly. Note direction of lever and lever holders at this time.

16. Clean all starter parts, but don't use grease dissolving solvents for cleaning the overrunning clutch and ball bearings.

17. Inspect armature commutator, shaft and gear, overrunning clutch pinion, reduction gear, brushes and springs for discoloration, damage or wear. Replace as required.

18. Inspect bearings for wear, dryness, roughness or other damage. Replace damaged bearings with new bearings which are prepacked with proper amount and type of grease.

19. Inspect armature commutator. If commutator is rough, it should be turned down. Don't turn to less than 1.48" O.D.

20. If test equipment is available:

a. Check the armature for short circuits by placing on a growler and holding hack saw blade over a armature core while armature is rotated. If saw blade vibrates, armature is shorted. Recheck after cleaning between the commutator bars. If saw blade still vibrates, replace the armature.

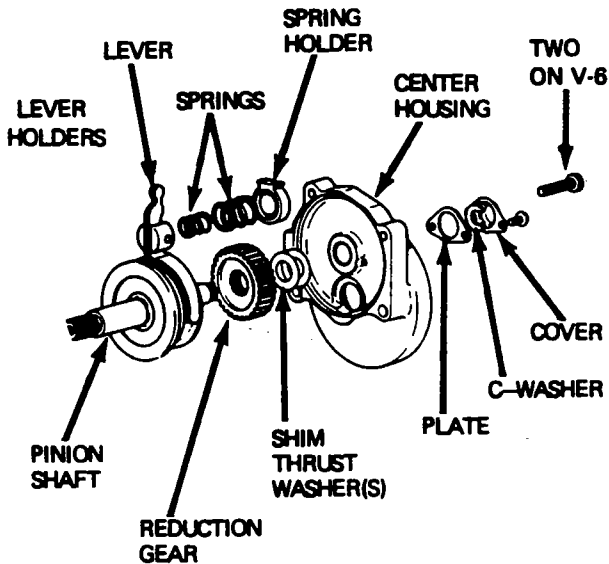

**PINION SHAFT (OVERRUNNING CLUTCH) REMOVAL**

11. Remove shaft cover on center housing by removing 2 screws, then remove C-shaped washer and plate.

12. Remove center housing bolt(s), then remove center housing and shim thrust washer(s). These washers determine pinion shaft end play which must be checked on reassembly of starter.

13. Remove reduction gear, spring holder and two lever springs.

Figure 6D-56 Starter Motor Disassembly (3 of 7)

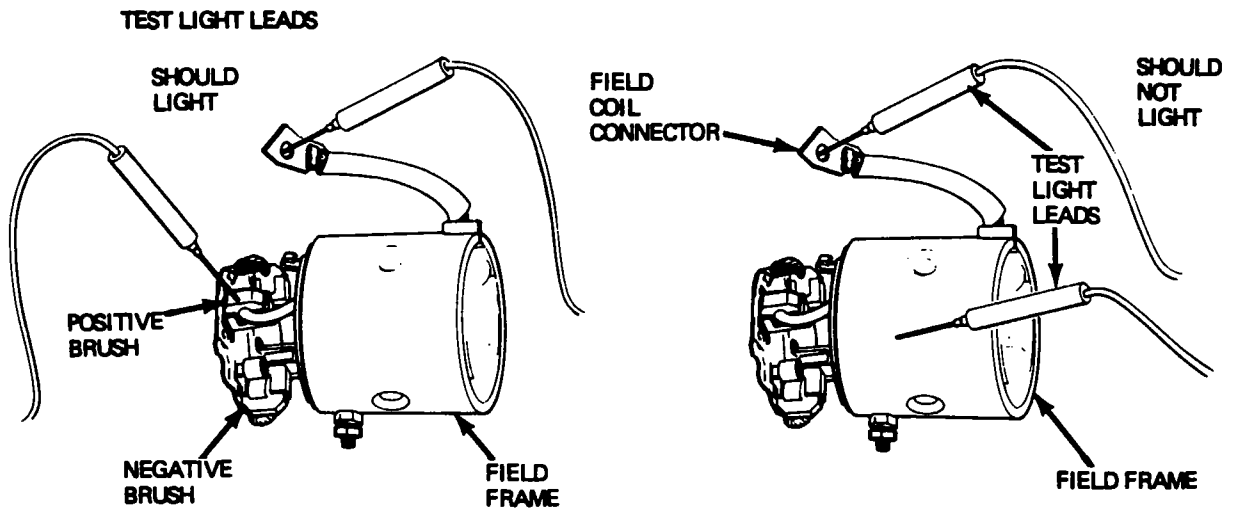
**TESTING FIELD COILS****TESTING FIELD COIL FOR OPEN**

21. With the brush holder assembly still attached to field frame, test the field coils. Using a self-powered test lamp, place one lead on the field coil connector and the other lead on a positive brush. Test lamp should light. If the lamp fails to light field coil is open and should be replaced. Repeat test on other positive brush.

**TESTING FIELD COIL FOR GROUND**

22. Using a self-powered test lamp, place one lead on the field coil connector and the other lead on the field frame. Test lamp should not light. If the lamp lights the field coils are grounded and the field frame assembly must be replaced since the coils are not serviced as a separate item. Visually inspect the coil for obvious signs of insulation breakdown and/or burns.

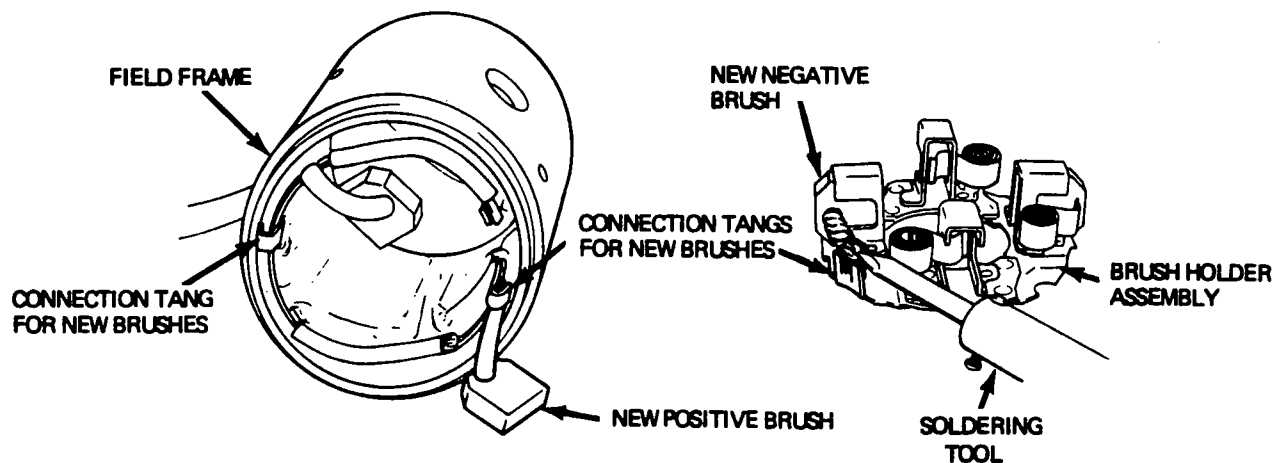
**BRUSH REPLACEMENT**

23. If necessary to replace brushes, proceed as follows:

a. Remove brush holder and negative brush assembly from field frame by removing positive brushes from brush holder.

b. Cut the old positive brush leads from the field coil bar as close to the brush connection point as possible. Cut the negative brush leads from the brush holder plate.

c. Solder new brush leads on the connection tangs

provided for installing new brushes (clean connection tang before soldering). Careful installation of the positive side (insulated) brushes is necessary to prevent grounding of the brush connection point having no insulation. When soldering, make a strong low resistance connection using a high temperature solder.

d. Reinstall positive and negative brushes in brush holder assembly in the backed out position described earlier.

**BEARING REPLACEMENT**

24. If it necessary to replace any bearings, use the following procedures.

**DRIVE END HOUSING BEARING**

25. Press the bearing out of the housing using a 15/16" socket or equivalent driving tool. The bearing should not be reused.

26. To install new bearing, secure housing in a suitable holding fixture and drive bearing into housing using a 1-1/8" socket or equivalent driving tool.

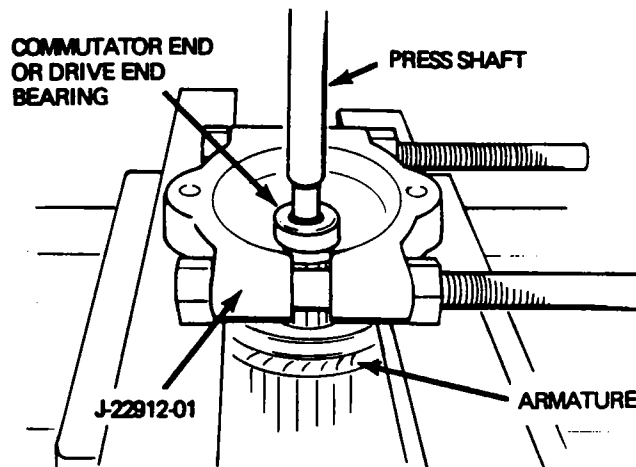
**ARMATURE COMMUTATOR END BEARING**

27. Attach tool J-22912-01 or equivalent as shown and press off armature shaft.

28. To install new bearing secure armature in a suitable holding fixture and drive bearing on armature shaft using 12mm socket or equivalent driving tool.

**ARMATURE DRIVE END BEARING**

29. Attach tool J-22912-01 or equivalent to drive end of armature as shown and remove bearing.

30. To install new bearing secure armature in a suitable holding fixture and drive bearing on armature shaft using 3/4" deep socket or equivalent driving tool.

**STARTER ASSEMBLY**

31. Lubricate the bearing surfaces and the splines on the pinion shaft assembly with lubricant 2960954 or equivalent.

32. Lubricate the nylon lever holders and both ends of lever with lubricant 2960954 or equivalent.

33. Install the lever assembly on the overrunning clutch with correct relation of parts as shown. This is important. If the lever is not properly positioned, pinion travel will be incorrect causing a lock-up in the clutch mechanism. Install the pinion shaft and lever assembly into the drive end housing.

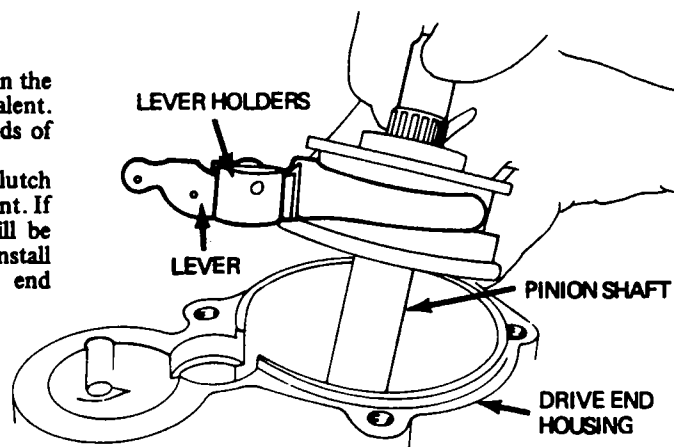

G35182-6D-E

Figure 6D-58 Starter Motor - Bearing Replacement and Assembly (5 of 7)

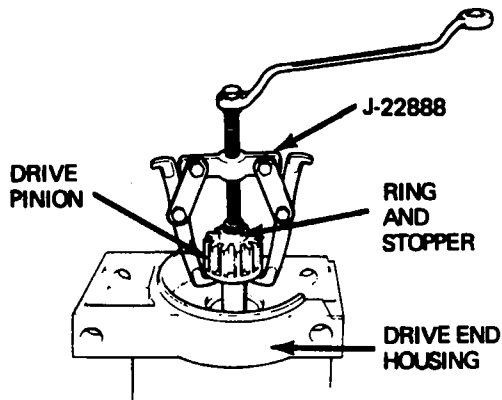

34. To install drive pinion, proceed as follows:

a. Slide spring, drive pinion and stopper over the shaft with the cupped surface of the stopper facing the end of the shaft.

b. While forcing drive pinion and stopper down against the drive end housing, install ring into groove on pinion shaft.

c. To force stopper over ring, use tool J-22888 or equivalent, installed as shown above. While using tool, it may be necessary to tap ring with top end of screwdriver to seat ring in stopper's groove.

35. Install the two lever springs and spring holder into the drive end housing.

36. Lubricate the reduction gear teeth with lubricant 1960954 or equivalent. Install gear and shim thrust washer(s) onto the pinion shaft assembly.

37. Position the center housing to the drive end housing, and install and tighten the two attaching bolts.

38. If either the drive end housing, pinion shaft, reduction gear, shim washer(s), or center housing were replaced it will be necessary to check the end play for the pinion shaft as follows:

a. Install the plate and C-shaped washer onto the end of the pinion shaft.

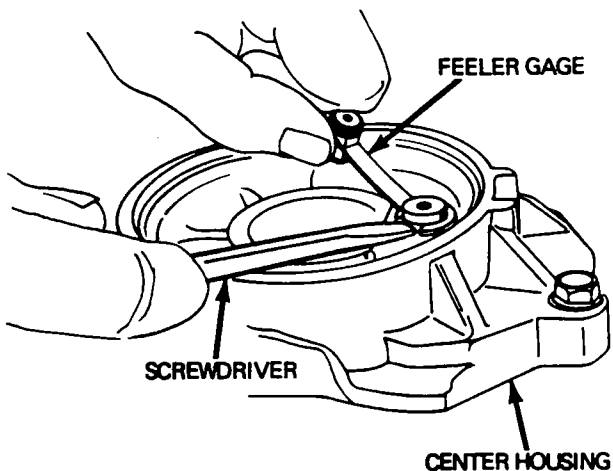

b. With the drive end housing mounted in a suitable holding fixture, measure end play as shown. Insert feeler gage between C-washer and cover plate. Move the pinion shaft in the axial direction with screwdriver to see whether a proper end play of .1 to .5 mm (.004 to .020 inch) is obtained.

c. If the end play does not fall within limits, remove the plate, C-shaped washer and center bracket, and then add or remove the shim thrust washers to adjust the end play and recheck. Shim thrust washers are available in two thicknesses .25 and .5mm (.010 and .020 inches).

d. After adjusting the end play, fill the cap 1/2 full with lubricant 1960954 or equivalent and install the cap. Then install and tighten the two attaching bolts.

39. Install the armature carefully engaging the splines of the shaft with the reduction gear by rotating the armature slightly to engage the splines.

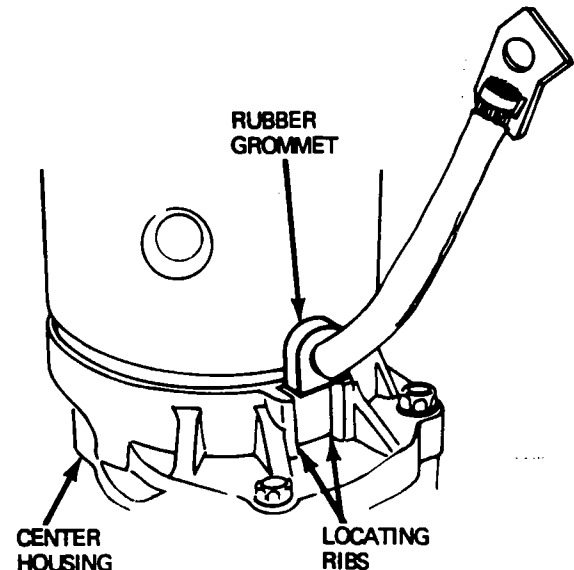

40. Position the field frame and brush holder assembly on the center housing as shown. The rubber grommet for the field coil lead must be installed in the locating ribs.

41. Install brushes in the proper location by prying back on springs to allow brushes to seat against commutator bars.

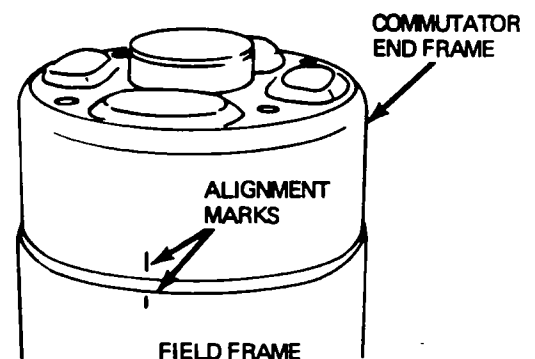

42. Position the commutator end frame onto the field frame so the alignment marks line up as shown. Install and tighten the two brush holder tightening screws. Install and tighten the two through bolts.

43. Install the solenoid switch and shims on the drive end housing, making sure the slot in the plunger engages with the top of the lever. Install and tighten the two bolts.

44. Connect the field coil connector to the solenoid switch terminal.

### CHECKING DRIVE PINION POSITION

When the starter has been disassembled or the solenoid switch has been replaced, it is necessary to check the pinion position. Pinion position must be correct to prevent the top of the lever from rubbing on the clutch collar during cranking.

45. Connect one 12 volt battery lead to the terminal "S" on the switch and momentarily connect the other to the starter frame. This will shift the pinion into cranking position and it will remain so until the battery is disconnected. Do not leave engaged more than 30 seconds at a time.

46. Set up dial indicator as shown with pinion engaged. Push the pinion shaft back by hand and measure the amount of pinion shaft movement. The amount corresponds to pinion clearance of current starters and should be .5 mm to 2.0 mm (.020 to .080 inch).

If the amount does not fall within limit, adjust it by adding or removing the shims which are located between the switch and the front bracket. Adding shims decreases the amount of the movement. Solenoid switch shims are available in two thicknesses .5 mm (.020 inch) and .25 mm (.010 inch).

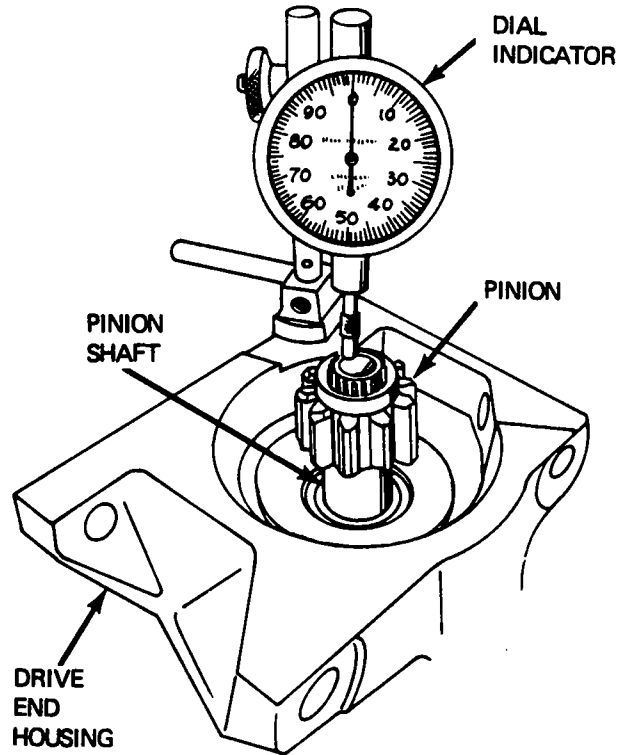

G35177-8D-E-1

Figure 6D-60 Starter Motor Assembly (7 of 7)

### STARTER SPECIFICATIONS

3.8L (VIN 3)

Production Part Number .....	1998545
Type .....	Aluminum Gear Reduction (AL/GR)
No Load Test @ 10 Volts	
Amps - Minimum .....	65
Amps - Maximum .....	90
RPM at Drive Pinion	
Minimum .....	3,500
Maximum .....	5,500