

# SECTION 9C

## TWILIGHT SENTINEL

### CONTENTS

General Description .....	9C-1
Diagnosis .....	9C-1
On-Car Service .....	9C-2

### GENERAL DESCRIPTION

The Twilight Sentinel (optional) provides automatic on-off control of the headlights. It will also keep the lights turned on for a preselected period of time after the ignition is turned off.

The system consists of a light sensitive photocell assembly, electronic amplifier, and a time delay control with an on-off switch. (See Figure 9C-1 and 9C-2.) Connections to the vehicle lights parallel the regular light switch connections, therefore the light switch must be turned off for automatic control.

The photocell assembly is mounted to obtain an unobstructed view of skylight through the windshield. The location is usually under the defroster/speaker grille or under a separate photocell grille on the I/P (see Figures 9C-3 thru 9C-8). The photocell uses its own separate retainer for positioning. The amplifier unit is mounted on the lower IP.

**See Figures 9C-3 thru 9C-8**

The time delay control and on-off switch is below the light switch on "A" series, to the right of the light switch on "G" series, and directly behind and concentric with the light switch knob on other carlines.

The electrical circuit for the Twilight Sentinel is shown in Section 8A.

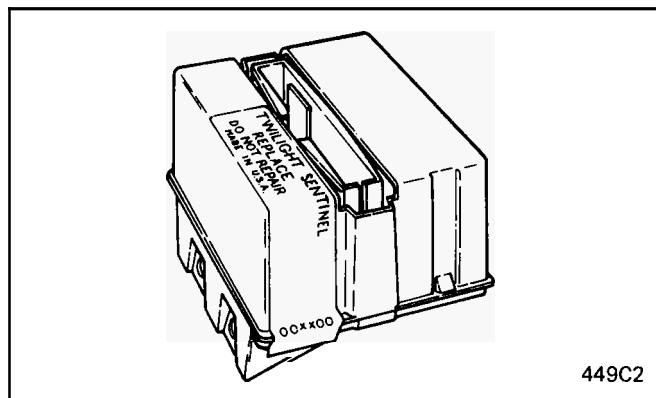

**Figure 9C-2 Twilight Sentinel Electronic Amplifier**

delay is normally 10 to 30 seconds, but in some units it could be as high as 60 seconds. The length of time delay is set in production and cannot be altered.

The variable time delay rheostat adjusts only the time delay during which the lights stay on after the ignition is turned off. This time delay can be adjusted from a few seconds to a maximum of 1-1/2 to 4-1/2 minutes.

### OPERATION - MANUAL

The system can be turned off by setting the time delay rheostat to OFF. This allows non-automatic control of the lights by use of the regular light switch.

If lights are desired during daylight, either of two methods can be used:

1. Lights can be operated with the regular light switch. The headlight switch is wired in parallel with the Twilight Sentinel and can bypass the system whether the rheostat is on or off. If the light switch is turned on lights will remain on after the ignition is turned off; however, when a car is equipped with chime package, a warning chime sounds as a reminder.
2. The photocell can be covered to block out light. This causes the lights to turn on and still enables the system to turn lights off automatically when ignition is turned off. (If the photocell has been exposed to light, the time delay must elapse before the lights will turn on).

### DIAGNOSIS

If a problem is suspected in the Twilight Sentinel System, do the system checks in Section 8A. Troubleshoot the system using the diagnostic tests and schematics also found in Section 8A.

### Headlights Turn On in Daylight when Ignition is Turned On

If the headlights come on in daylight when the ignition is turned on, check for an open in the photocell leads. The

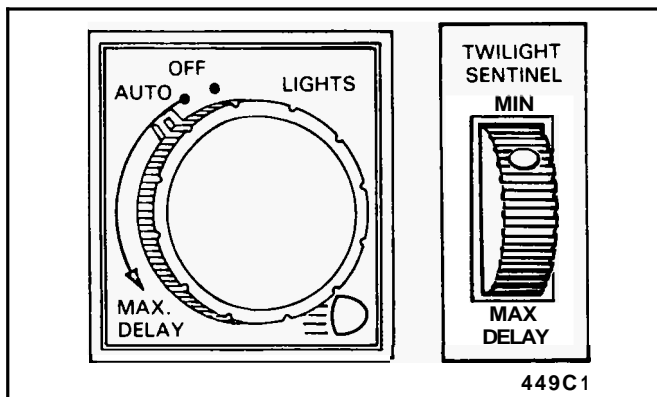

**Figure 9C-1 Typical Sentinel Controls**

### OPERATION - AUTOMATIC

The Twilight Sentinel operates automatically when (1) the ignition switch is on, (2) the headlight switch is off, and (3) the control rheostat (Figure 9C-1) is on (any position away from the OFF position). When these conditions are met, the system turns on lights automatically when road illumination becomes necessary. As daylight increases in the morning and road illumination is no longer necessary, it turns the lights off.

A time delay circuit in the amplifier reduces the chance of undesired switching on or off of lights while passing under viaducts, trees, bright lights, etc. The time

photocell itself may have dropped from its mounting and might be somewhere in darkness under the IP.

There is no timer adjustment on the amplifier for turn-on or turn-off for lights.

### Headlights Turn On Too Late Or Too Early in Evening (Or Off Too Late Or Too Early in Morning)

Refer to Section 8A to diagnose this problem.

### Headlights Turn Off Only When Delay Control Switch Is In The Off Position

If the lights stay on in daylight with the ignition switch off, the most likely cause is an open in the black ground wire to the amplifier. If the black wire is reconnected or repaired, do the system checks in Section 8A to make sure the amplifier is functioning properly.

### Warning Chime Operation

The "lights-on" warning chime sounds when the light switch is on and ignition is off. In this case, the Twilight Sentinel amplifier supplies a voltage signal to the chime module to sound the warning chime.

## ON-CAR SERVICE

### TWILIGHT SENTINEL AMPLIFIER

The amplifier is **not** matched to the photocell; if the amplifier is replaced, the photocell (if functioning properly) does **not** need to be replaced.

### TWILIGHT SENTINEL PHOTOCELL

The photocell is **not** matched to the amplifier; if the photocell is replaced, the amplifier (if functioning properly) does **not** need to be replaced.

#### Removal "A" Series

(See Figure 9C-3)

1. Disconnect negative battery cable.
2. Remove left side hush panel.
3. Remove 2 screws securing amplifier to lower IP assembly. (It may help to remove ashtray.)
4. Disconnect electrical connector; remove amplifier.
5. Access to the photocell unit can be gained by removing the speaker, defroster grille.

#### Installation "A" Series

Reverse removal procedure to install.

#### Removal "B" Series

(See Figure 9C-6)

1. Disconnect negative battery cable.
2. Remove dash top cover.
3. Disconnect electrical connector.
4. Pinch photocell retainer; lift photocell out by rotating retainer.
5. Remove glovebox shell.
6. Remove ashtray.
7. Remove amplifier from IP support.

#### Installation "B" Series

Reverse removal procedure to install.

#### Removal "E" Series

(See Figures 9C-4 and 5)

1. Disconnect negative battery cable.
2. Remove glove box shell.
3. Lower right side of lower dash hush panel to gain access to lower trim panel screws.
4. Remove center trim panel by pulling straight out.
5. Remove right trim panel.
6. Remove amplifier.
7. Remove photocell by disconnecting photocell electrical connector and pop up retainer; rotate retainer to separate from photocell.

#### Installation "E" Series

Reverse removal procedure to install.

#### Removal "G" Series

(See Figure 9C-7)

1. Disconnect negative battery cable.
2. Remove IP top cover.
3. Remove spacer on back side of retainer; then pinch retainer to remove from panel; rotate retainer to separate from photocell.
4. Remove right hush panel.
5. Remove support bracket.
6. Flip glovebox shell down and out of the way.
7. Remove amplifier. and removing (2) 7mm screws.

#### Installation "G" Series

Reverse removal procedure to install.

#### Removal and Installation "C" Series

(See Figure 9C-8)

Procedures to remove and replace the photocell are similar to the "B" Series steps above.

## HEADLAMP SWITCH TWILIGHT SENTINEL RHEOSTAT

#### Removal "A" Series

(See Figure 9C-3)

1. Disconnect negative battery cable.
2. Remove instrument panel and filler panel trim plates.
3. Remove IP left switch cover by removing 3 screws and rocking cover from top to bottom until it releases.
4. Remove rheostat switch, pulling it straight out.

#### Installation "A" Series

Reverse removal procedure to install.

#### Removal "B" Series

(See Figure 9C-6)

1. Disconnect negative battery cable.
2. Remove headlight switch knob and IP trim plate.
3. Remove headlight switch by removing 5/8 nut and pulling switch forward far enough to release rod.
4. Disconnect rheostate electrical connector and remove rheostat.

#### Installation "B" Series

Reverse removal procedure to install.

**Removal "E" Series**

{See Figures 9C-4 and 5}

1. Disconnect negative battery cable.
2. Remove IP trim plate.
3. Remove headlamp switch panel assembly by removing 2 screws.
4. Remove Twilight Sentinel Control Switch Rheostat.
5. Disconnect rheostat electrical connector.

**Installation "E" Series**

Reverse removal procedure to install.

**Removal "G" Series**

{See Figure 9C-6}

1. Disconnect negative battery cable.
2. Remove left hand trim plate.
3. Remove 3 (7mm) screws.
4. Pull switch assembly straight out (headlamp, dimmer, and twilight sentinel switches are all one piece).

**Installation "G" Series**

Reverse removal procedure to install.

**Removal and Installation "C" Series**

{See Figure 9C-8}

Procedures to remove and replace the control rheostat are similar to the "B" Series steps above.

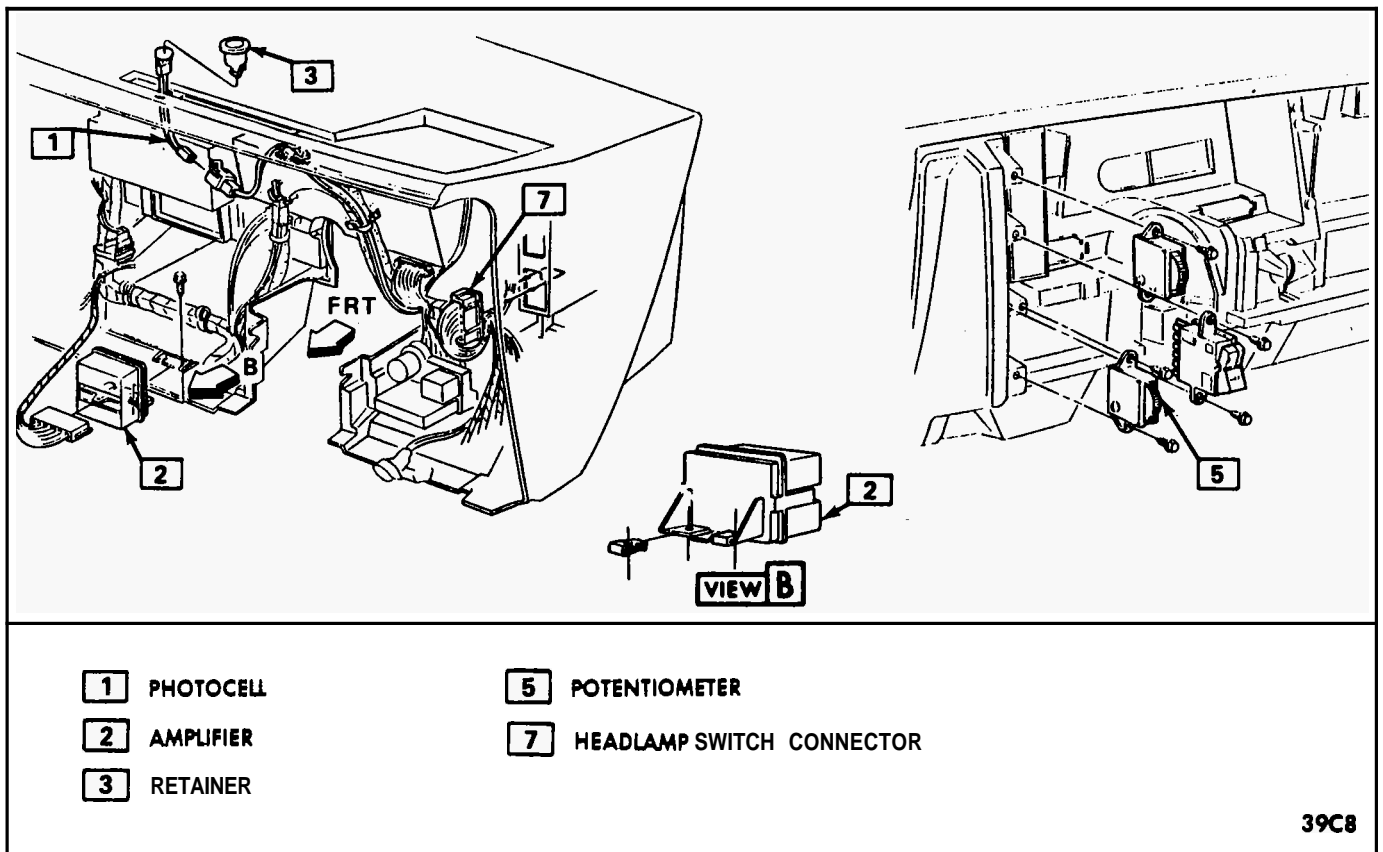

39C8

Figure 9C-3 Twilight Sentinel "A" Series

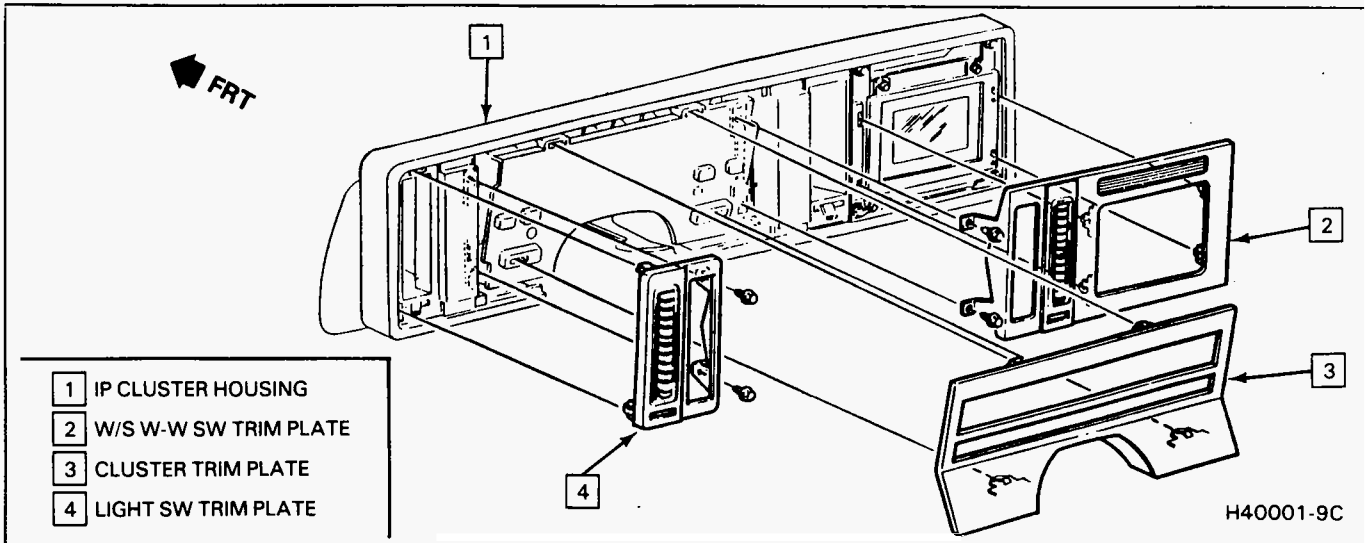

Figure 9C-4 Switch Trim Plates, "E" Series

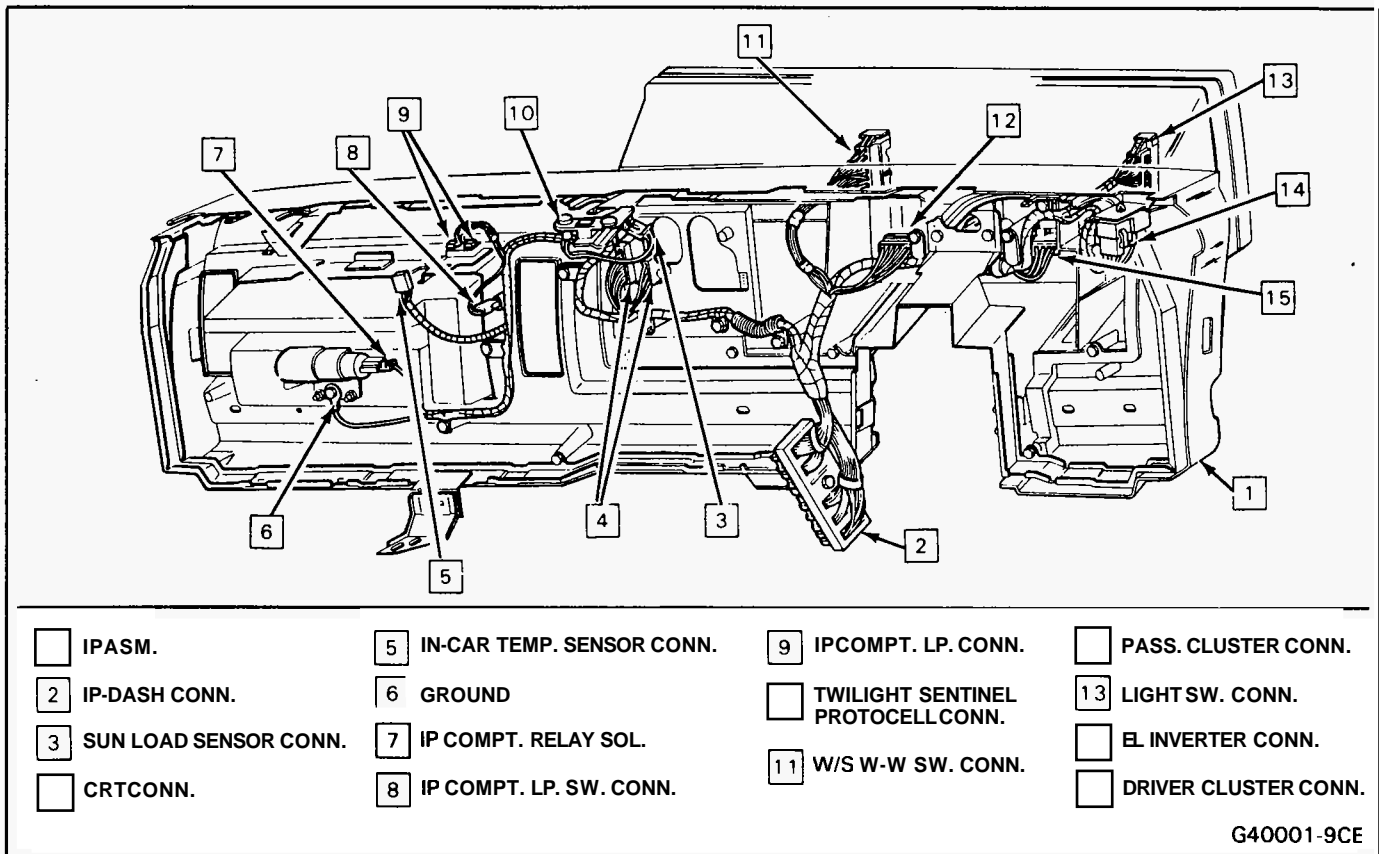
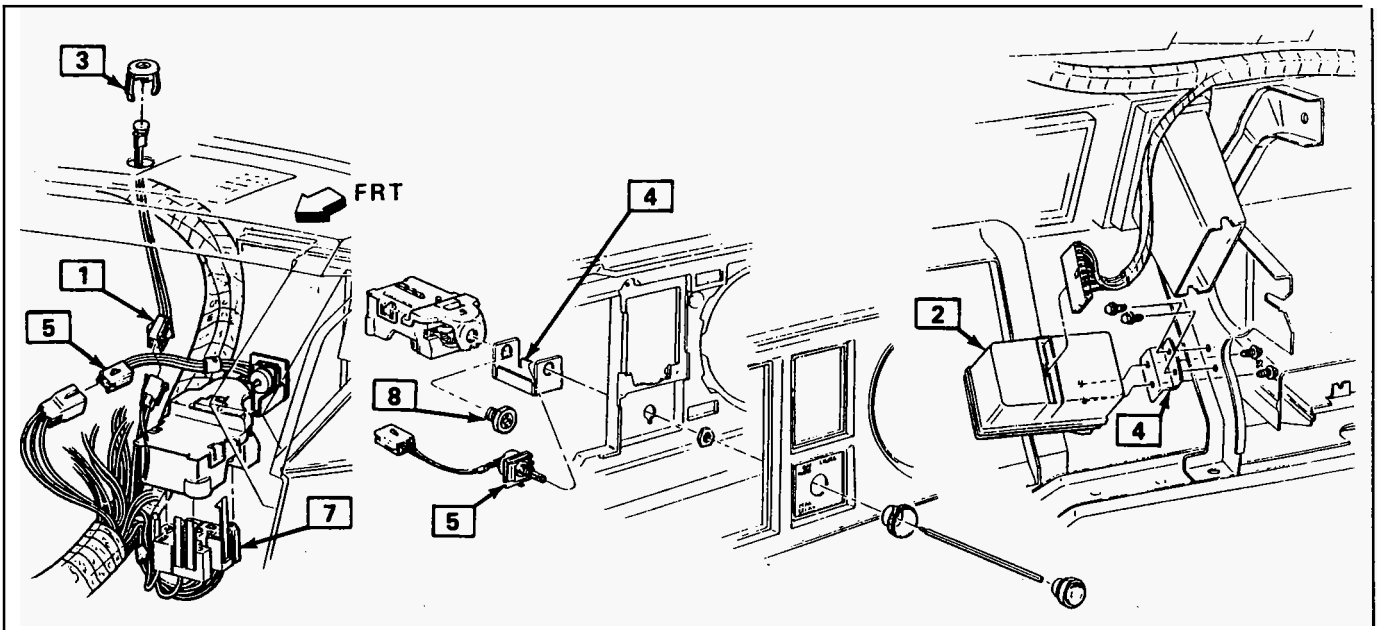

Figure 9C-5 Twilight Sentinel "E" Series



- |                    |                                    |                  |
|--------------------|------------------------------------|------------------|
| <b>1</b> PHOTOCELL | <b>4</b> BRACKET                   | <b>8</b> BUSHING |
| <b>2</b> AMPLIFIER | <b>5</b> POTENTIOMETER             |                  |
| <b>3</b> RETAINER  | <b>7</b> HEADLAMP SWITCH CONNECTOR |                  |

39C9

Figure 9C-6 Twilight Sentinel "B" Series

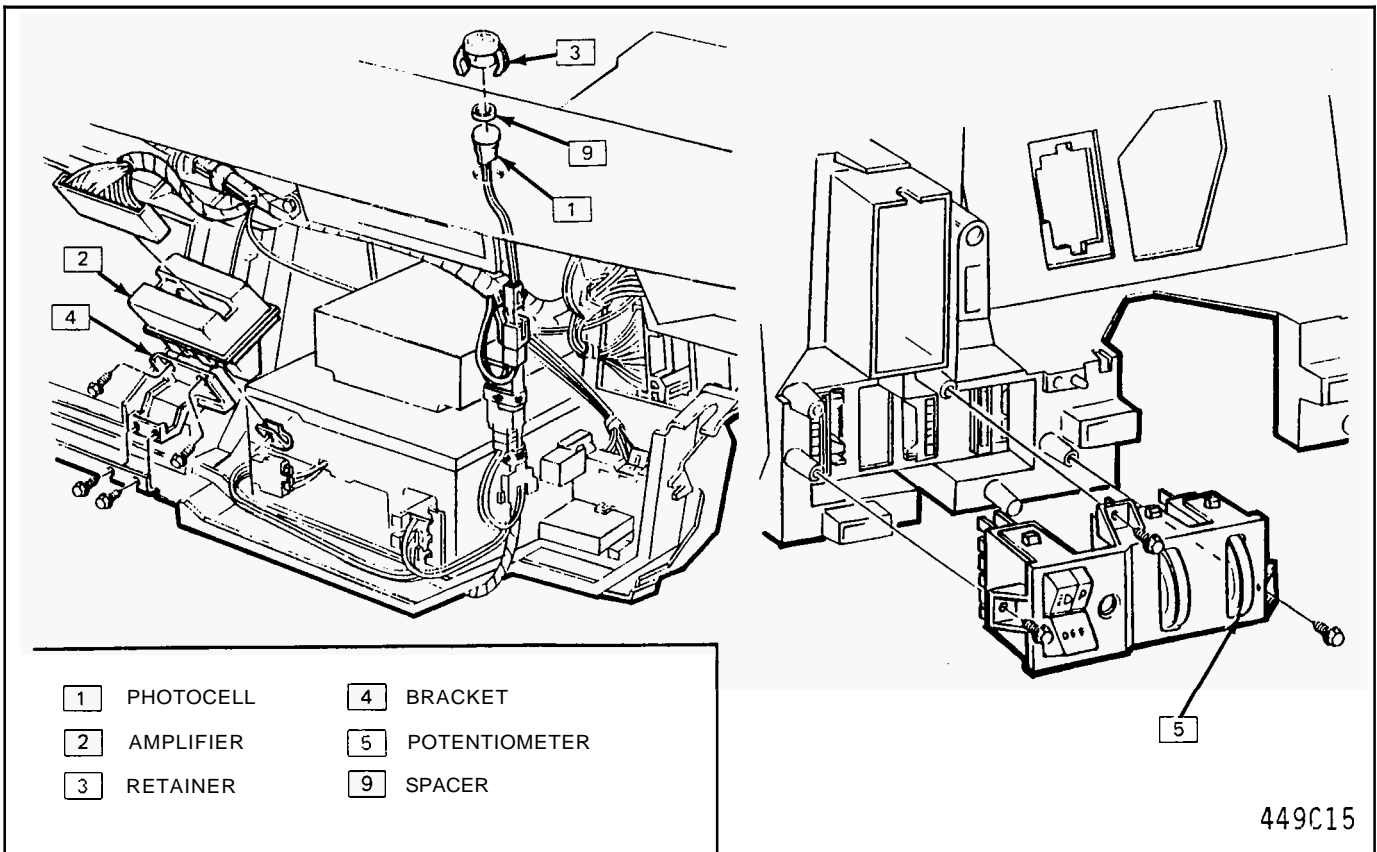

- |                    |                        |
|--------------------|------------------------|
| <b>1</b> PHOTOCELL | <b>4</b> BRACKET       |
| <b>2</b> AMPLIFIER | <b>5</b> POTENTIOMETER |
| <b>3</b> RETAINER  | <b>9</b> SPACER        |

449C15

Figure 9C-7 Twilight Sentinel "G" Series

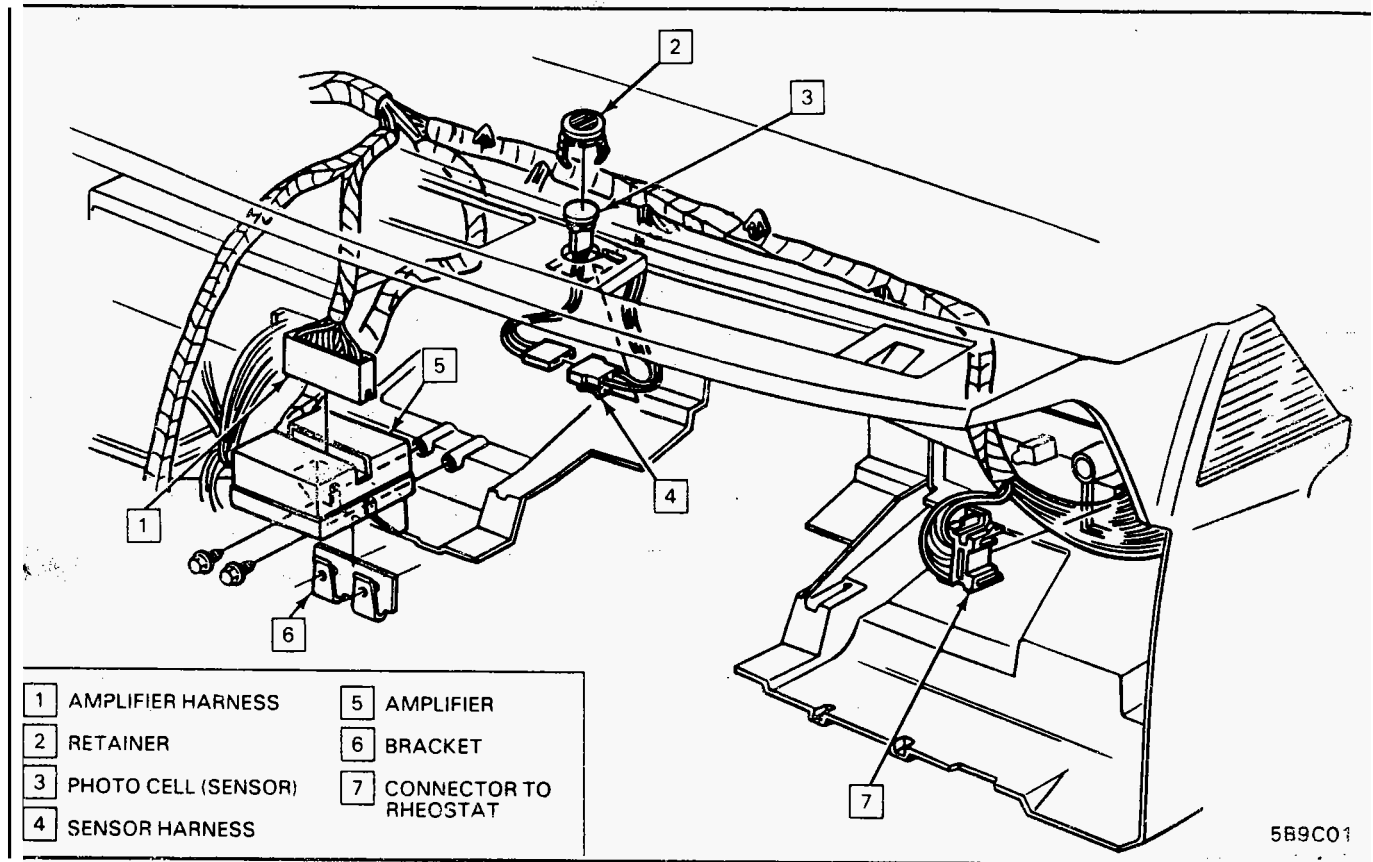

Figure 9C-8 Twilight Sentinel "C" Series