

THEFT DETERRENT SYSTEM

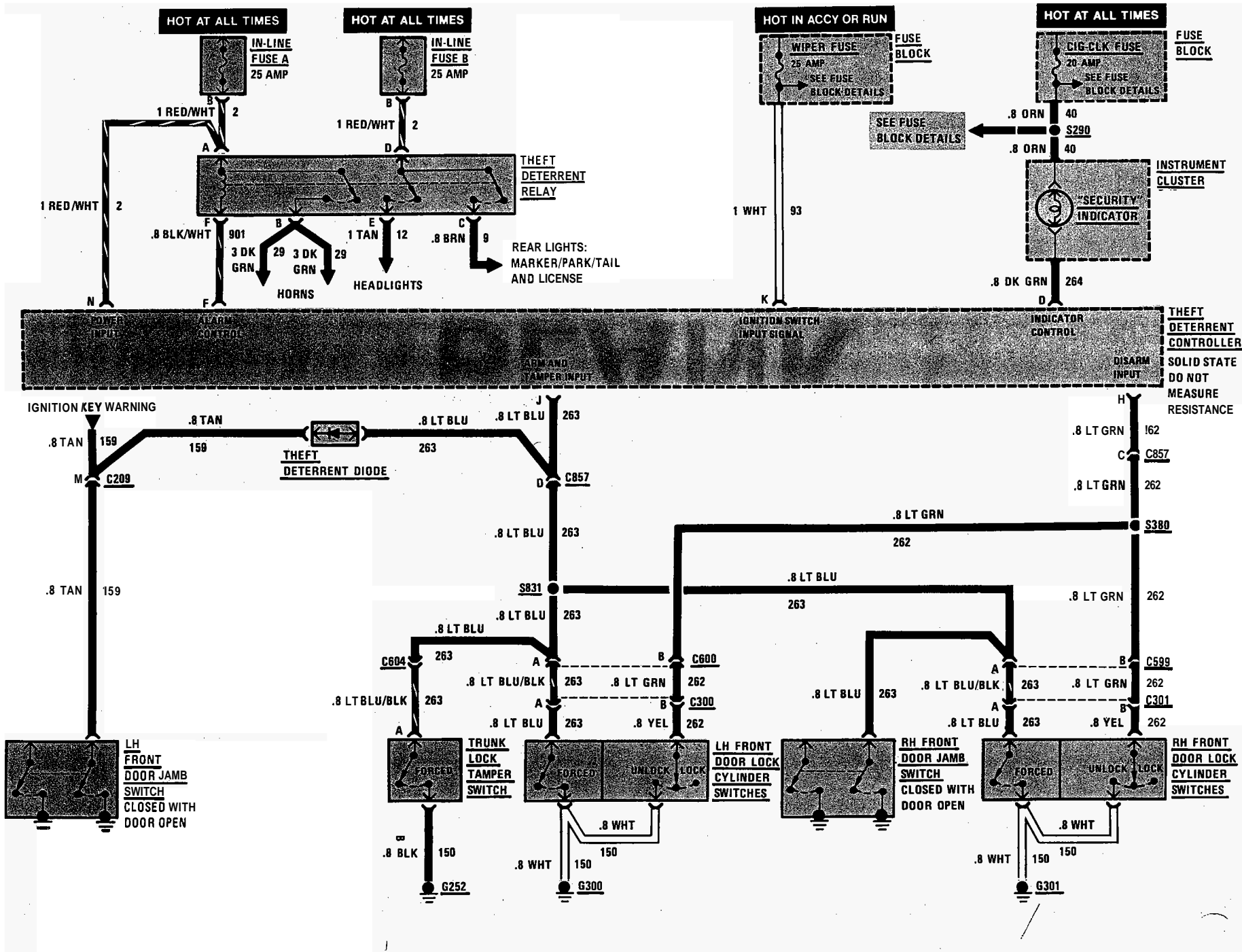

BLANK

THEFT DETERRENT SYSTEM

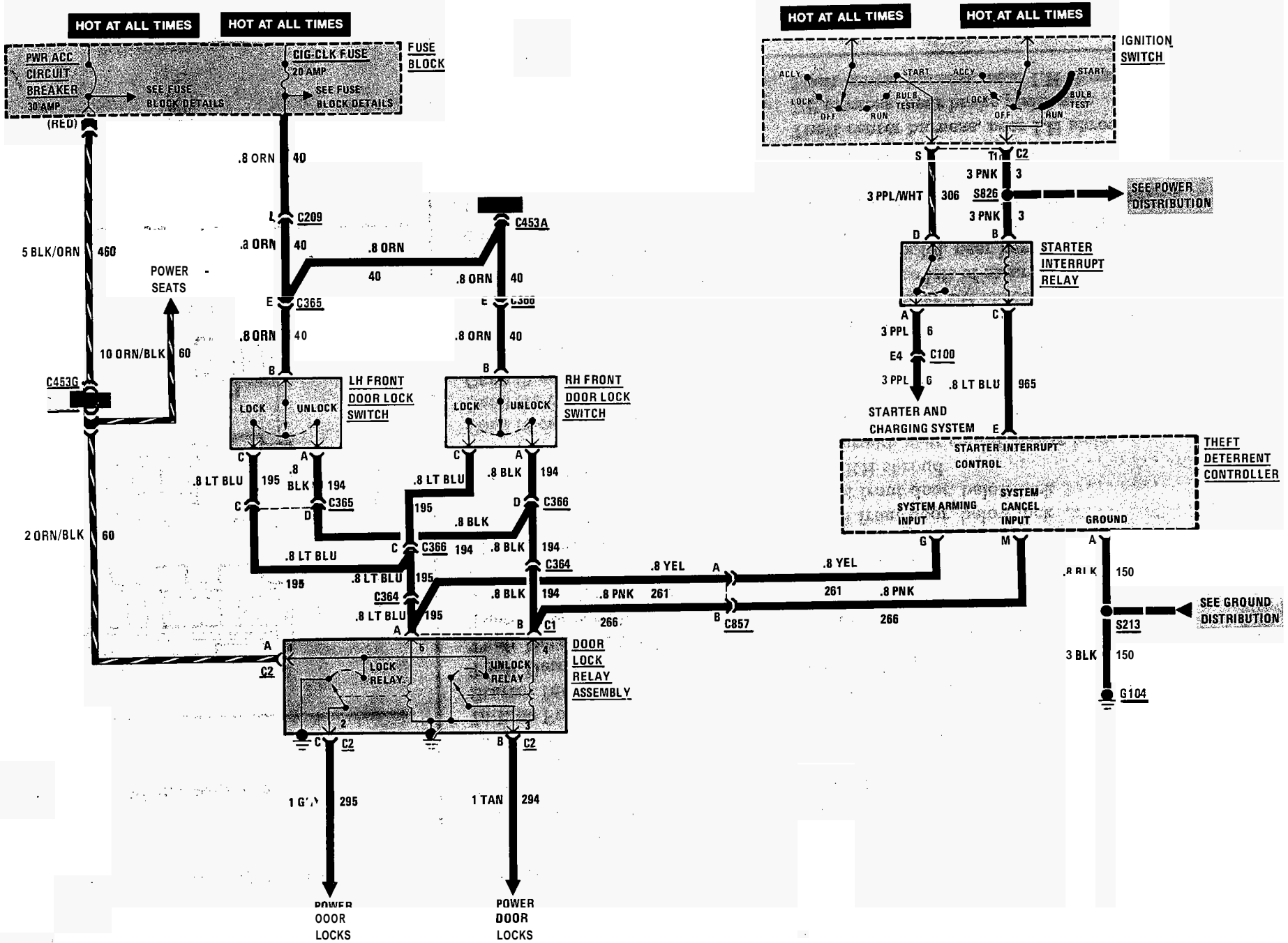

HARNESS CONNECTOR FACES

C100, See Page 202-0

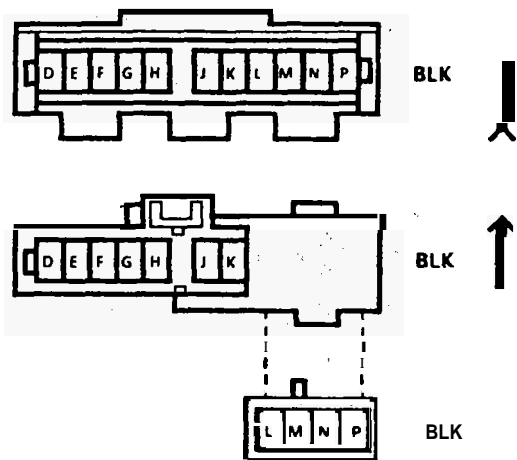

v11002.0
C209

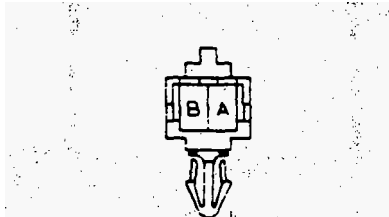

WHT 12010487
C300

COMPONENT LOCATION

Page-Figure

Door Lock Cylinder Switches	In door. near key cylinder	
Door Lock Relay Assembly	Lower RH shroud. at bottom access hole	201-22-E
Fuse Block	Under LH side of I/P	201-12-A
Ignition Switch	Base of steering column	201-13-A
In-Line Fuse A	Taped to I/P harness. behind RH side of cluster	201-11-A
In-Line Fuse B	Taped to I/P harness. behind RH side of cluster	201-11-A
Starter Interrupt Relay	Taped to I/P harness. near fuse block	201-11-A
Theft Deterrent Controller	Behind I/P, near LH shroud	201-11-A
Theft Deterrent Diode	Behind LH side of I/P, in C857	201-11-A
Theft Deterrent Relay	Behind I/P, left of steering column	201-11-A
Trunk Lock Tamper Switch	Rear center of trunk lid. at lid lock cylinder	201-22-C
C100 (45 cavities)	LH rear of engine compartment	201- 9-B
C209 (11 cavities)	Attached to LH side of fuse block	201-13-42
C300 (2 cavities)	In LH front door. below lock	201-23-B
C301 (2 cavities)	In RH front door, below lock	201-23-B
C364 (2 cavities)	Near RH shroud	201-15-B
C365 (6 cavities)	LH shroud. near center access hole	201-23-B
C366 (6 cavities)	RH shroud. near center access hole	201-23-B
C453 (18 cavities)	Behind LH side of I/P, near shroud	201-14-A
C599 (2 cavities)	Below RH side of I/P, at upper RH shroud	201-15-B
C600 (2 cavities)	Below LH side of I/P, at upper LH shroud	201-15-B
C604 (1 cavity)	Base of LH shroud	201-15-B
C857 (4 cavities)	Behind I/P, near LH shroud	201-11-A
G104	Behind I/P, to left of steering column	201-15-A
G252	Rear of trunk lid. near key tumbler	201-22-C
G300	In LH front door. near lock cylinder switch	
G301	In RH front door. near lock cylinder switch	
S213	I/P harness. above radio	201-16-A
S290	I/P harness. above steering column	201-15-A
S380	Theft center harness. near LH shroud	201-11-A
S826	I/P harness. near brake pedal arm	201-12-A
S831	Theft center harness. near LH shroud	201-15-B

THEFT DETERRENT SYSTEM

HARNESS CONNECTOR FACES

C301, See C300

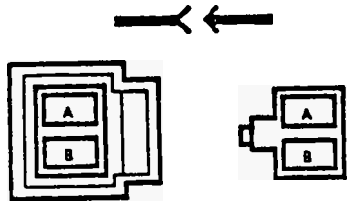

ELK GRY

02977373 GRA
C364

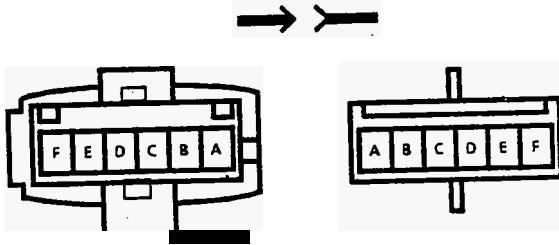

BLK BLK

V06000.3
C365

C366, See C365

C453, See Page 202-1

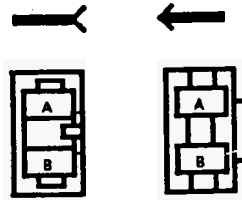

BLK WHT

V02002.3
c599

C600, See C599

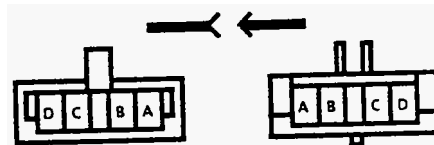

BLK BLK

V04004.2
C857

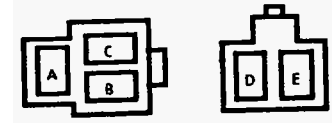

C2 BLK C1 GRY

V00018.0
Door Lock Relay Assembly



BLK 12004155
Door Lock Switch (LH)

Door Lock Switch (RH),
See Door Lock Switch (LH)

THEFT DETERRENT SYSTEM

HARNESS CONNECTOR FACES

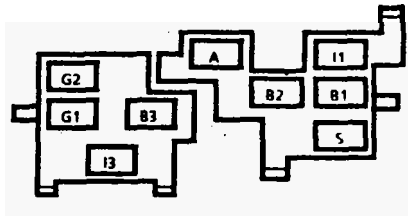

C1 BLK C2 BLU

V00019.0
Igniton Switch



BLK 12010105
In-Line Fuse (A) Fuse Holder

In-Line Fuse (B) Fuse Holder,
See In-Line Fuse (A)
Fuse Holder

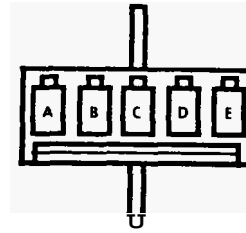

BLK
V000013.1
Starter Interrupt Relay

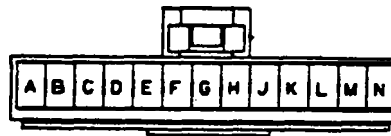

BLK 12015130
Theft Deterrent Controller

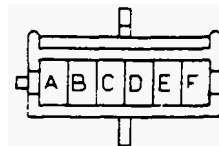

BLK 8917540
Theft Deterrent Relay



BLK 8900863
Trunk Lock Tamper Switch

THEFT DETERRENT SYSTEM

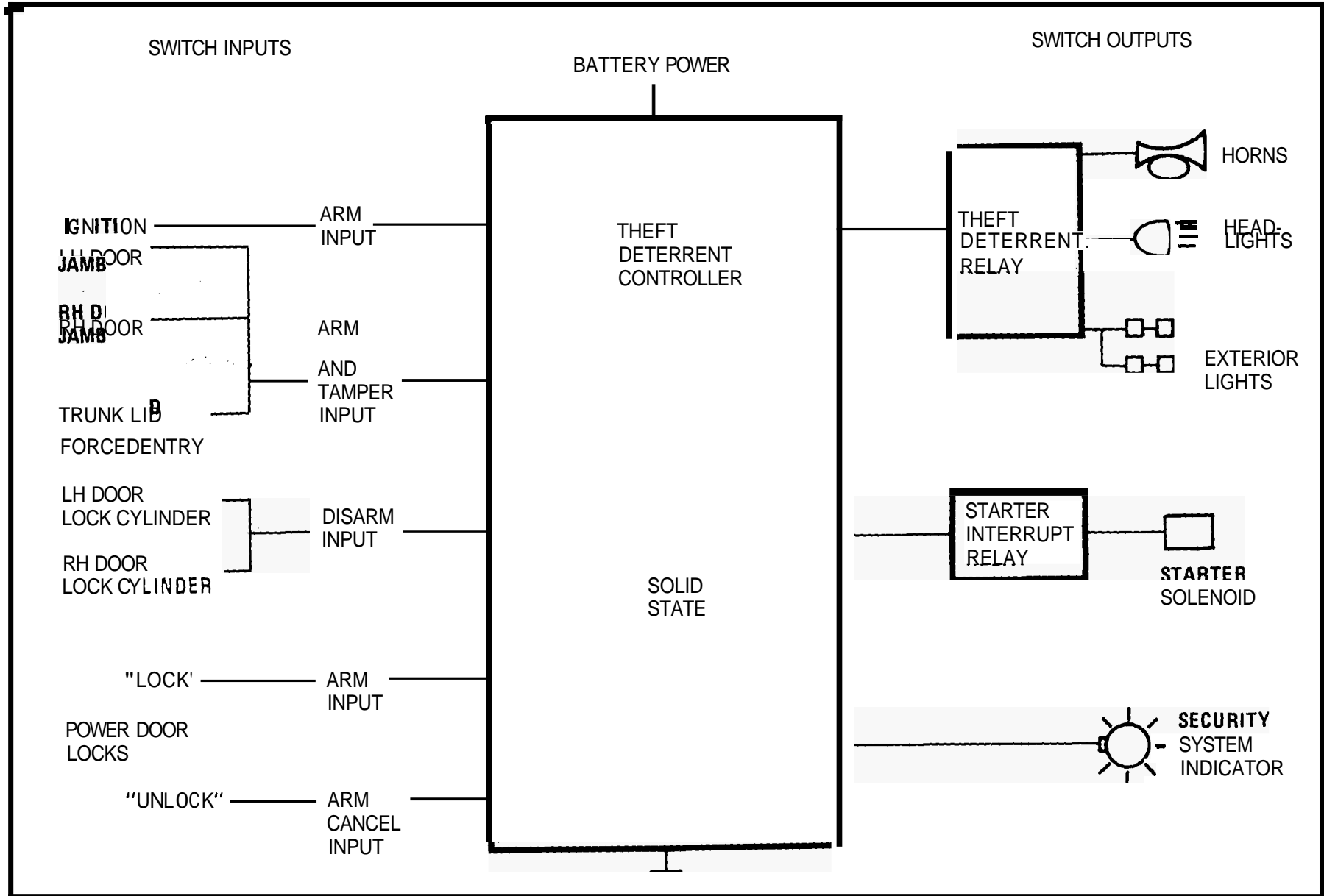

THEFT DETERRENT SYSTEM

TROUBLESHOOTING HINTS

- Try the following checks before doing the System Check.
- 1. Check the Wiper Circuit Breaker by operating the Windshield Wiper.
- 2. Check the PWR ACC Circuit Breaker by operating Defogger.
- 3. Check the CLK-CIG Fuse by operating the Glove Box Light.
- 4. Visually check In-Line Fuses A and B.
- 5. If the Ignition Key Warning is set off by all doors, replace the Theft Deterrent Diode (see schematic).
- 6. If the Horns are sounding without the lights coming on, replace the Theft Deterrent Relay.
- Go to System Check for a guide to normal operation.
- Go to System Diagnosis for diagnostic tests.

SYSTEM CHECK

- Use the System Check Table as a guide to normal operation.

NOTE: To reduce alarm noise, muffle the vehicle horns with rags. Put all windows fully down before testing.

ACTION	NORMAL RESULT
Turn the Ignition Switch to RUN and then to Off Open the driver's door	SECURITY Indicator flashes
Move the front Door Lock Switch to the LOCK position (LH door open)	SECURITY Indicator remains on
Close the door (stay in the car)	SECURITY Indicator goes out (system is armed)
Unlock the LH door using the Door Lock Post, then open the door	Horns pulse on and off, Headlights flash on and off, and Exterior Lights flash on and off These alarms cycle on and off approximately once a second for two to four minutes
While alarms are operating, turn the Ignition Key to START	Starter does not operate (Engine does not start)
Disarming the System	
Get out of the car Using the Key, unlock the LH door	Alarms stop
Rearm the system using the RH Front Door Lock Switch Get out of the car and close the door	System is armed
Unlock the RH door with the key and open it	Alarms do not sound (the key unlock disarms the system)
Rearm the system while remaining in the car	System is armed
Put the key in the Ignition and turn it to RUN	System is disarmed
Unlock the LH door using the Door Lock Post and open the door	Alarms do not sound
Rearm the system and unlock the RH door using the Door Lock Post	System is armed
Open and close the RH Door	Alarms sound
After alarms stop in about three minutes, open RH door	Alarms sound
Unlock RH door using the key	Alarms stop

THEFT DETERRENT SYSTEM

While remaining in the car, lock each door using the Door Lock Posts of the outside Key Lock and close all doors (do not use the Power Door Locks)	SECURITY Indicator goes off when the last door is closed (System is not armed)
Unlock the LH door using the Door Lock Post and open the door	Alarms do not sound

SYSTEM DIAGNOSIS

- Diagnostic steps for the symptoms listed in the following table are listed after the table.

SYMPTOM TABLE

- A: System won't arm; Indicator flashes after Door Switch **is** locked
- B: System won't arm; Indicator stays on after door is closed
- C: System won't cancel arming when Door Lock Switch **is** unlocked
- D: System won't disarm with Door Key
- E: **Alarms** won't operate; system arms
- F: Only the Horn or some lights operate when alarm is activated (Horn and **all** lights work when operated from their switches)
- G: Starter Interrupt doesn't work; Alarms operate
- H: Security Indicator doesn't work
- I: Alarm sounds when **no** tamper inputs are present
- J: Starter Motor will not operate

- If the system does not have one of the symptoms listed, do all of the following tests.

A: SYSTEM WON'T ARM; INDICATOR FLASHES AFTER DOOR SWITCH IS LOCKED

Measure: TEST LAMP		
At: THEFT DETERRENT CONTROLLER (Disconnected)		
Condition:		
• Ignition Switch: ACCY or RUN		
Connect Between	Correct Display	For Diagnosis
K (WHT) & Ground	Test Lamp on	See 1
• All Doors closed		
K (WHT) & Ground	Test Lamp off	See 2
• Each Door Open (one at a time)		
K (WHT) & J (LT BLU)	Test Lamp on	See 3
• Hold each Lock Switch in the LOCK Position		
G (YEL) & Ground	Test Lamp on	see 4

(Continued in next column)

(Continued from previous column)

- If **all** tests yield the correct lamp response, replace the Theft Deterrent Controller.
- 1. Check the WHT (93) wire for an open (see schematic).
- 2. Check the Door Jamb Switches, Door Lock Cylinder Switches, TAN (159) wire and LT BLU (263) wire for a short to ground (see schematic).
- 3. Check the LT BLU (263) wire, TAN (159) wire and Door Jamb Switches for an open (see schematic).
- 4. Check the YEL (261) wire for an open (see schematic).

B: SYSTEM WON'T ARM; INDICATOR STAYS ON AFTER DOOR IS CLOSED

Connect: SELF POWERED TEST LAMP		
At: THEFT DETERRENT MODULE CONNECTOR (Disconnected)		
Condition:		
• Both doors close		
Connect Between	Correct Result	For Diagnosis
J (LT BLU) & Ground	Test lamp off	See 1
J (LT BLU) & Ground	Test Lamp on	See 2

STAYS ON AFTER DOOR IS CLOSED
Continued on next page)

THEFT DETERRENT SYSTEM

(B: SYSTEM WON'T ARM, INDICATOR STAYS ON AFTER DOOR IS CLOSED continued from previous page)

- If all tests yield the correct lamp response, replace the Theft Deterrent Controller.
1. Check the Door Jamb Switches, Door Lock Cylinder Switches, TAN (159) wire and LT BLU (263) wire for a short to ground (see schematic).
 2. Check the Door Jamb Switches, the LT BLU (263) wire and the TAN (159) wire for an open.

C: SYSTEM WON'T CANCEL ARMING WHEN DOOR LOCK SWITCH IS UNLOCKED

Connect: TEST LAMP At: THEFT DETERRENT CONTROLLER CONNECTOR (Disconnected) Condition: <ul style="list-style-type: none"> • RH or LH Front Door Lock Switch: UNLOCK 		
Connect Between	Correct Display	For Diagnosis
M (PNK) & A (ORN/BLK)	Test Lamp on	See 1

D: SYSTEM WON'T DISARM WITH DOOR KEY

Connect: TEST LAMP At: THEFT DETERRENT CONTROLLER CONNECTOR (Disconnected) Condition: <ul style="list-style-type: none"> • Ignition Switch: ACCY 		
Connect Between	Correct Display	For Diagnosis
K (WHT) & K (WHT)	Test Lamp on	See 1
<ul style="list-style-type: none"> • Key in UNLOCK position in either door 		
H (LT GRN) & K (WHT) Ground	Test Lamp on	See 2
<ul style="list-style-type: none"> • If all tests yield the correct lamp response, replace the Theft Deterrent Controller. <ol style="list-style-type: none"> 1. Check the WHT (93) wire for an open (see schematic). 2. Check the LT GRN (262) wire and Door Lock Cylinder Switches for an open (see schematic). 		

E: ALARMS WON'T OPERATE; SYSTEM ARMS

Connect: TEST LAMP At: THEFT DETERRENT CONTROLLER CONNECTOR (Disconnected)		
Connect Between	Correct Display	For Diagnosis
r (BLK/WHT) & Ground	Test Lamp on	See 1
J (LTBLU) & N (RED/WHT)	Test Lamp on	See 2

THEFT DETERRENT SYSTEM

F: ONLY THE HORNS OR SOME LIGHTS OPERATE WHEN ALARM IS ACTIVATED (HORNS AND ALL LIGHTS WORK WHEN OPERATED FROM THEIR SWITCHES)

Connect: TEST LAMP At: THEFT DETERRENT RELAY (Disconnected)		
Connect Between	Correct Display	For Diagnosis
D (RED/WHT) & Ground	Test Lamp on	See 1
D (RED/WHT) & B (DK GRN)	Test Lamp on	see 2
D (RED/WHT) & E (TAN)	Test Lamp on	see 3
D (RED/WHT) & C (BRN)	Test Lamp on	See 4
<ul style="list-style-type: none"> If all tests yield the correct response, replace the Theft Deterrent Relay. <ol style="list-style-type: none"> Check the RED/WHT (2) wire and Fuse B for an open (see schematic). Check the DK GRN (29) wire for an open (see schematic). Check the TAN (12) wire for an open (see schematic). Check the BRN (9) wire for an open (see schematic). 		

G: STARTER INTERRUPT DOESN'T WORK, ALARMS OPERATE

Connect: TEST LAMP At: STARTER INTERRUPT RELAY CONNECTOR (Disconnected)		
Conditions: • Ignition Switch: RUN		
Connect Between	Correct Display	For Diagnosis
B (PNK) & Ground	Test Lamp on	see 1
• Alarms sounding		
B (PNK) & C (LT BLU)	Test Lamp on	See 2
<ul style="list-style-type: none"> If the lamp lights in both tests, replace the Starter Interrupt Relay. <ol style="list-style-type: none"> Check the PNK (3) wire and Ignition Switch for an open (see schematic). Check the LT BLU (865) wire for an open, then replace the Theft Deterrent Controller. 		

H: SECURITY INDICATOR DOESN'T WORK

Connect: VOLTMETER At: THEFT DETERRENT CONTROLLER CONNECTOR (Disconnected)		
Connect Between	Correct Voltage	For Diagnosis
N (RED/WHT) & Ground	Battery	See 1
N (RED/WHT) & A (BLK)	Battery	See 2
• If the lamp lights in all the tests, replace the Theft Deterrent Controller.		
K (WHT) & A (BLK)	Battery	See 3
D (DK GRN) & A (BLK)	Battery	See 4
<ol style="list-style-type: none"> Check: the RED/WHT (2) wire for an open (see schematic). Check the BLK (150) wire for an open (see schematic). Check the WHT (93) wire for an open (see schematic). Check the Security Indicator bulb and the DK GRN (264) wire for an open. 		

(Continued on next page)

THEFT DETERRENT SYSTEM

(Continued from previous page)

I: ALARM SOUNDS WHEN NO TAMPER INPUTS ARE PRESENT (TABLE 1)

Connect: TEST LAMP At: THEFT DETERRENT RELAY CONNECTOR (Disconnected) Conditions: <ul style="list-style-type: none"> Theft Deterrent System: ARMED All doors: CLOSED 		
Connect Between	Correct Display	For Diagnosis
A (RED/WHT) & F (BLK/WHT)	Test Lamp off	See 1
<ul style="list-style-type: none"> If the lamp does not light, replace the Theft Deterrent Relay. <ol style="list-style-type: none"> Check BLK/WHT (901) wire for a short, then go to Table 2. 		

I: ALARM SOUNDS WHEN NO TAMPER INPUTS ARE PRESENT (TABLE 2)

Connect: TEST LAMP At: THEFT DETERRENT CONTROLLER CONNECTOR (Disconnected) Condition: <ul style="list-style-type: none"> All doors closed 		
Connect Between	Correct Display	For Diagnosis
J (LTBLU) & N (RED/WHT)	Test Lamp off	See 1
A (BLK) & N (RED/WHT)	Test Lamp on	See 2
<ul style="list-style-type: none"> If all tests give the correct response, there is still the possibility of intermittent shorts. Check LT BLU (263) wire and all door switches for exposed wiring or a faulty switch, then replace the Theft Deterrent Controller. <ol style="list-style-type: none"> Check the Door Jamb Switches and LT BLU (263) wire for shorts (see schematic). Check BLK (150) wire for an open. 		

J: STARTER MOTOR WILL NOT OPERATE

Connect: FUSED JUMPER At: STARTER INTERRUPT RELAY CONNECTOR (Disconnected) Condition: <ul style="list-style-type: none"> (Hold) Ignition Switch in the START position 		
Connect Between	Correct Result	For Diagnosis
D (PPL/WHT) & A (PPL)	Starter Motor cranks the engine	See 1
<ul style="list-style-type: none"> If the Starter Motor cranks the engine, replace the Starter Interrupt Relay. <ol style="list-style-type: none"> The problem is not in the Theft Deterrent System. Refer to Cell 30 (Start/Charging). 		

THEFT DETERRENT RELAY

CIRCUIT OPERATION

When the Theft Deterrent System has been turned on, or armed, it will automatically operate alarms. It sounds the vehicle horns, flashes the exterior lights, and interrupts the starter circuit. This happens when any of the doors are opened, or forced entry switches on the door locks and/or any of the trunk locks are closed.

Alarms

The light and horn alarms are operated by the Theft Deterrent Relay. The coil of this relay is grounded by the Solid State Theft Deterrent Controller to turn on the relay. When the relay contacts close, battery voltage is supplied to the headlights, exterior lights, and the horn. The controller then opens the relay coil circuit to turn off the alarms. They will pulse on and off every second for 2 to 4 minutes after the system has been triggered by tampering or forced entry.

Starter Interrupt

The starter circuit is disabled by the Starter Interrupt Relay. This relay coil is also grounded by the Theft Deterrent Controller when the alarms have been set off. The relay is energized when the Ignition Switch is in RUN, BULB TEST, or START. Its contacts then open and break the circuit to the Starter Solenoid. This prevents the engine from starting.

Arming

The arming sequence begins with the Ignition Switch turned off. This removes battery

voltage at terminal K, the Ignition ON Input. If either Door Lock Switch is moved to LOCK, and at least one door is open, momentary battery voltage is applied at terminal G, the System Disarming Input. At the same time, the open door places a ground at terminal J. The arming sequence is completed by closing the last door, which removes the ground signal from terminal J.

Cancellation

The arming sequence can be cancelled. This is done by moving a Front Door Lock Switch to the UNLOCK position before the door is closed to complete the arming of the system. Battery voltage is applied momentarily to terminal M with the door switch in UNLOCK. This cancels the arming.

Disarming

When one of the doors is unlocked with a key, a grounding switch in the Front Door Lock Cylinder closes. This grounds terminal H of the controller, the Disarm Input. The system is disarmed and no alarms will operate when a door is opened.

The system can be disarmed from inside the vehicle with the key. Turning the Ignition Switch to RUN applies battery voltage to terminal K of the controller, the Ignition ON Input.

Tampering

The alarms are set off when terminal J, the Tamper Input, is grounded. The door jamb switches close to ground, the Tamper Input, with the door open. In addition, the Forced

Entry switches close when there is motion between a door or the trunk and its switch. This happens when a door lock is forced or removed. The Forced Entry switches then ground the Tamper Input and set off the alarms.

The Theft Deterrent Diode isolates the LH Front Door Jamb Switch. The Voice or Alarm Information System also uses this switch. The diode prevents the other switches in the Theft Deterrent System from operating the information system.

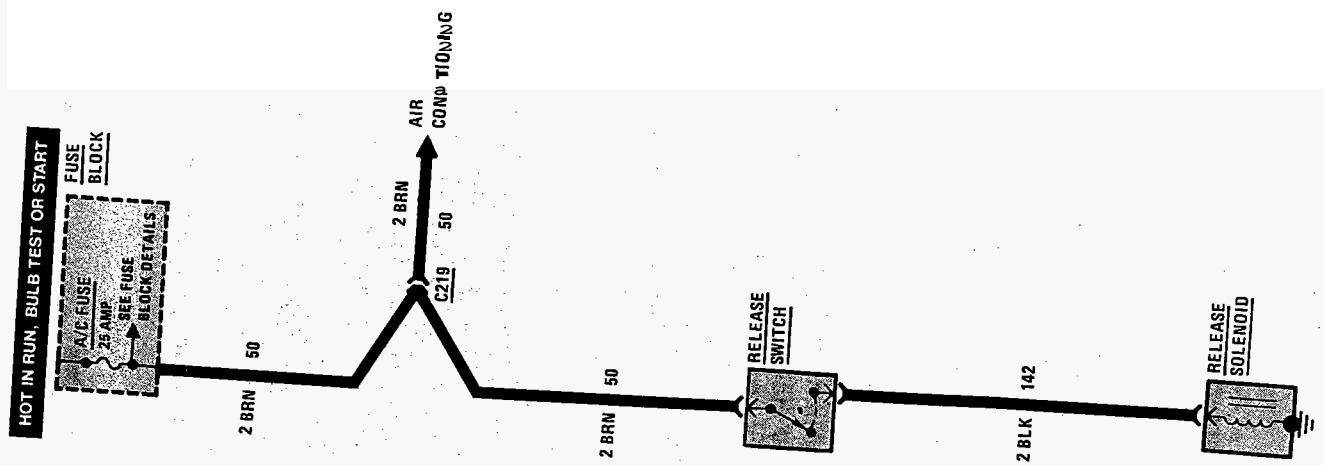

TRUNK RELEASE

B

TRUNK RELEASE

TROUBLESHOOTING HINTS

- Try the following checks before doing the System Check.
- 1. Check the A/C Fuse by operating the Heater.
- 2. Check that the Trunk Release Solenoid case ground is clean and tight.
- Go to System Check for a guide to normal operation.
- Go to System Diagnosis for diagnostic tests.

SYSTEM CHECK

- Use the System Check Table as a guide to normal operation.

SYSTEM CHECK TABLE

ACTION	NORMAL RESULT
With Ignition Switch in RUN, press Trunk Release Button	Trunk lid unlatches

- Refer to System Diagnosis if a result is not normal.

SYSTEM DIAGNOSIS

- Make the measurements given in the following Tables if the Trunk Release does not operate properly.

COMPONENT LOCATION

Page-Figure

Fuse Block.	Under LH side of I/P.	201-12-A
Release Solenoid	Rear center of trunk lid.	201-22-B
C219 (1cavity).....	Behind I/P, near control head.	201-17-A

At: TRUNK RELEASE SOLENOID CONNECTOR (Disconnected) Condition: • Ignition Switch: RUN		
Measure Between	Correct Voltage	For Diagnosis
BLK & Ground	0 Volts	See 1
• Press and hold the Trunk Release button		
BLK &	Battery	See 1
• If both voltages are correct, repair/replace Trunk Release Solenoid . 1. Go to Table 2.		

Measure Between	Correct Voltage	For Diagnosis
BRN & Ground	Battery	See 1
• If both voltages are correct, repair/replace the Trunk Release Switch. 1. Check/repair the BRN (50)wire. 2. Check/repair the BLK (142)wire.		

CIRCUIT OPERATION

With the Ignition Switch in RUN, BULB TEST, or START, voltage is applied through the A/C Fuse to the Trunk Release Switch, With the Switch closed, voltage is applied to the Trunk Release Solenoid, releasing the trunk lock.

POWER SEATS: THREE MOTORS

LH SEAT

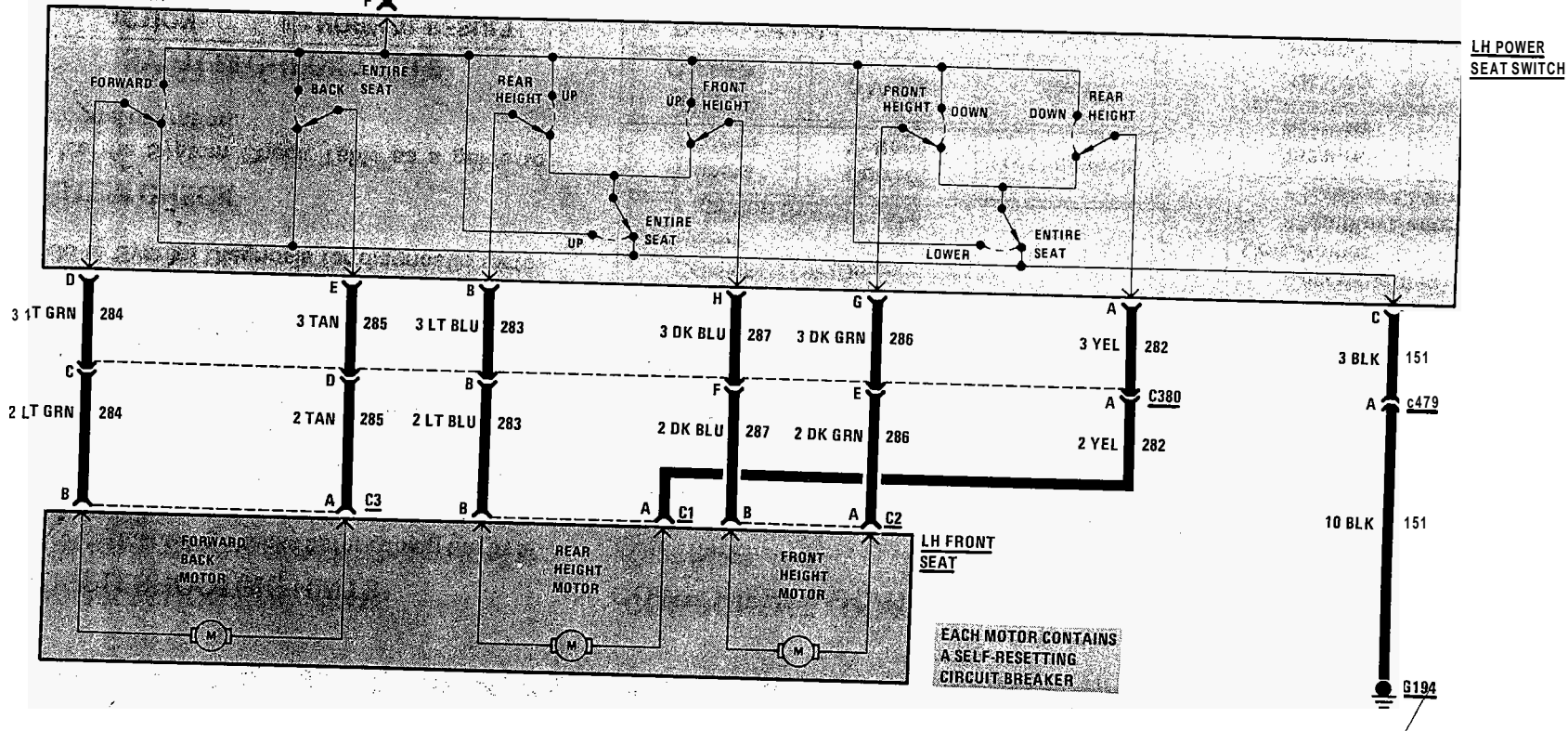
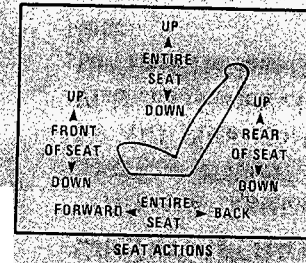
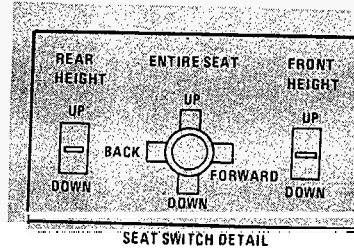
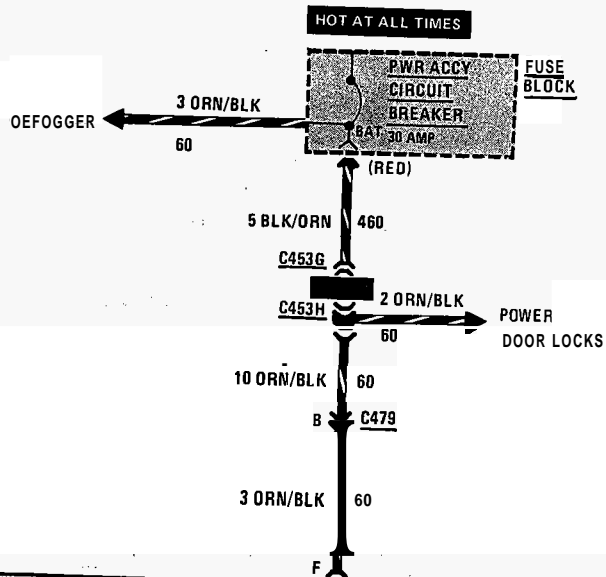

POWER SEATS: THREE MOTORS

HARNESS CONNECTOR FACES

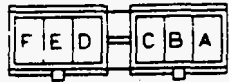

BLK 12004677
C380

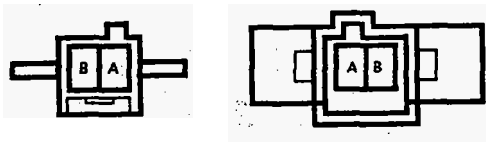

WHT

WHT

V02003.0
c479

COMPONENT LOCATION

Page-Figure

Fuse Block.	Under LH side of I/P.	201-12-A
C380 (6 cavities)	Under LH front seat	
C453 (18 cavities)	Behind LH side of I/P, near shroud	201-14-A
C479 (2 cavities)	Under LH front seat.	201-24-A
G194	On floor pan, near LH front door sill	201-24-A

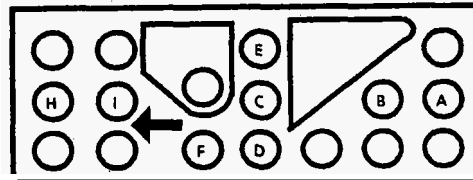

WHT

V00037.0
LH Seat Switch

C453, See Page 202-1

POWER SEATS: THREE MOTORS

TROUBLESHOOTING HINTS

- Try the following checks before doing the System Diagnosis.
- 1. **If none of the Seat Functions operate**, check the PWR/ACC Circuit Breaker, by operating the power door **locks**.
- 2. **If the Rear or Front height does not function**, but the entire seat moves up and down, replace the Seat Switch.
- 3. **If the entire seat moves up and down**, but the rear or front height does not, replace the Seat Switch.
- Go to System Check for a guide to normal operation.
- Go to System Diagnosis for diagnostic tests.

SYSTEM CHECK

- Use the System Check Table as a guide to normal operation.

ACTION	NORMAL RESULTS
Move Rear Height switch up and down	Rear of seat moves up and down
Move Front Height switch up and down	Front of seat moves up and down
Move the Entire Seat switch up and down	Entire seat moves up and down
Move the Entire Seat switch Forward and Back	Entire seat moves forward and back

- Refer to System Diagnosis when a result is not normal.

SYSTEM DIAGNOSIS

- Diagnostic steps for the symptoms listed in the following table are listed after the table.

SYMPTOM TABLE

A: None of the seat functions work
B: Some, but not all seat functions work

A: NONE OF THE SEAT FUNCTIONS WORK

Connect: TEST LAMP At: POWER SEAT SWITCH CONNECTOR (Connected)		
Connect Between	Correct Display	For Diagnosis
ORNBLK (60) & Ground ORN/BLK (60) & BLK (151)	Test Lamp ON	See 1
	Test Lamp ON	See 2
<ul style="list-style-type: none"> • If lamp lights in both tests, check Connector C380 then replace the Seat Switch. 1. Check the PWR/ACCY Fuse and the ORNBLK (151) wire (see schematic). 2. Check Ground G194 and BLK (151) wire (see schematic). 		

B: SOME, BUT NOT ALL SEAT FUNCTIONS WORK

Connect: TEST LAMP At: POWER SEAT SWITCH CONNECTOR (Connected) Condition: • Entire Seat Switch in the Forward and Back position		
Connect Between	Correct Display	For Diagnosis
LT GRN (284) & TAN (285)	Test Lamp ON	See 1
• Rear Height Switch in either position		
LT BLU (283) & YEL (282)	Test lamp ON	see 1
DK BLU (287) & DK GRN (286)	Test Lamp ON	see 1
<ul style="list-style-type: none"> • If lamp lights in all tests, test the wires leading to the appropriate Motor for an open, then replace the Motor (see schematic). 1. Replace the Seat Switch. 		

POWER SEATS: THREE MOTORS

CIRCUIT OPERATION,

There are three reversible motors that operate the Power Seats. The front and back of a seat are operated by different motors. They can be raised or lowered independently of each other. When the Entire Seat Switch is pushed to the UP or DOWN position, both motors run to move the front and back of the seat at the same time.

The Forward-Back Motor is operated by the Entire Seat Switch. When it is held in the FORWARD position, battery voltage is applied through the switch contacts to the LT GRN wire and the Forward-Back Motor. The motor is grounded through the TAN wire and the contact of the Back Switch to G194. The motor runs to drive the seat forward until the switch is released.

In the BACK position, the TAN wire receives battery voltage and the LT GRN wire is grounded. This reversed polarity causes the motor to run in the opposite direction and drive the seat backward.

The Front Height Motor works in a similar way when the Front Height Switch is operated.

To raise the entire seat, the Entire Seat Switch is held in the UP position. This applies battery voltage to both the LT BLU and DK BLU wires, and both the Front Height and Rear Height Motors. The YEL and the DK GRN wires are grounded through the Height Switches and Entire Seat Down Switch that was not operated. Both motors run to drive the entire seat up. A similar action occurs to move the entire seat down.

Each motor contains a self-resetting circuit breaker to protect it from overload.

RADIO

AM/FM/MONO

HOT IN ACCY OR RUN

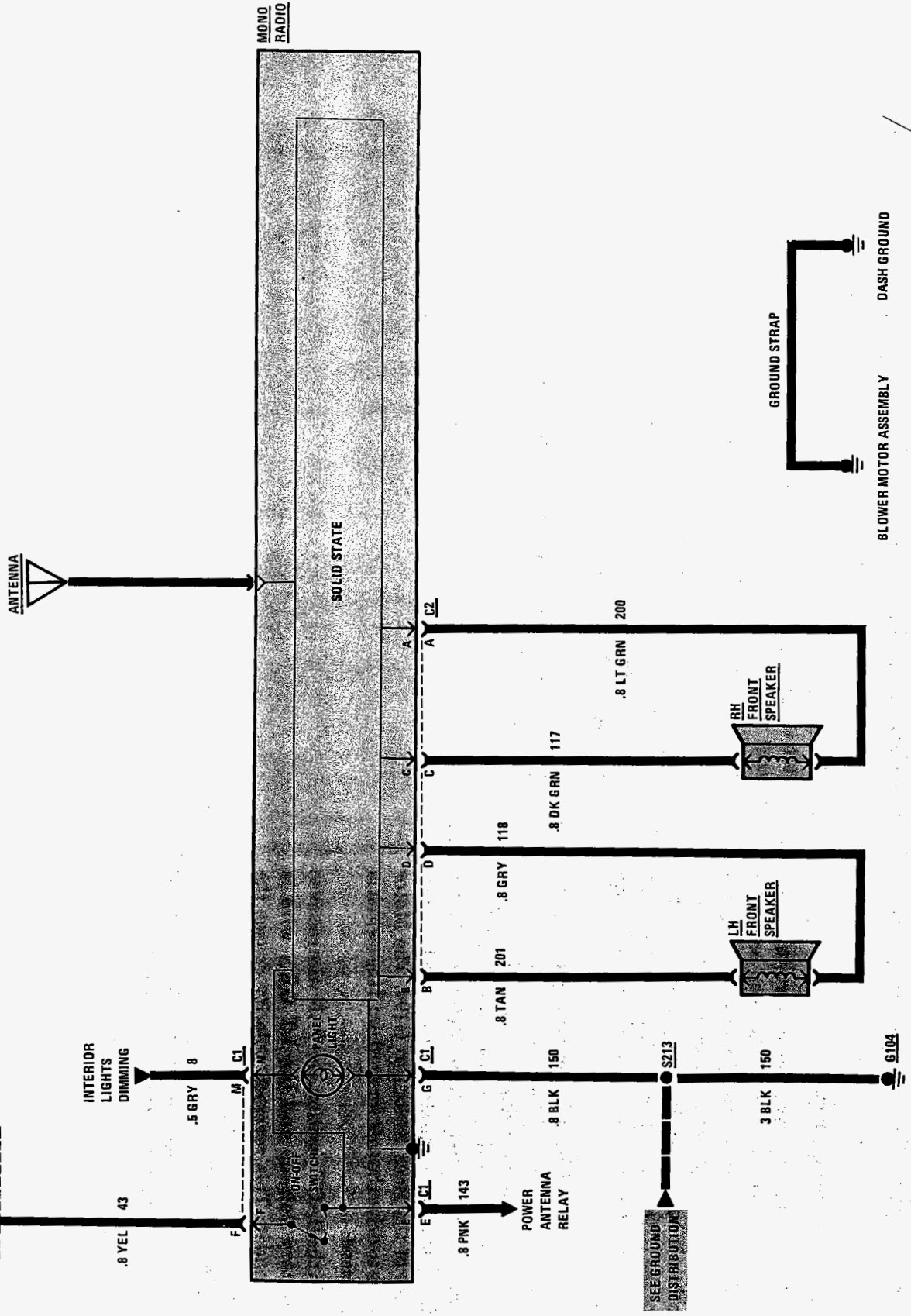

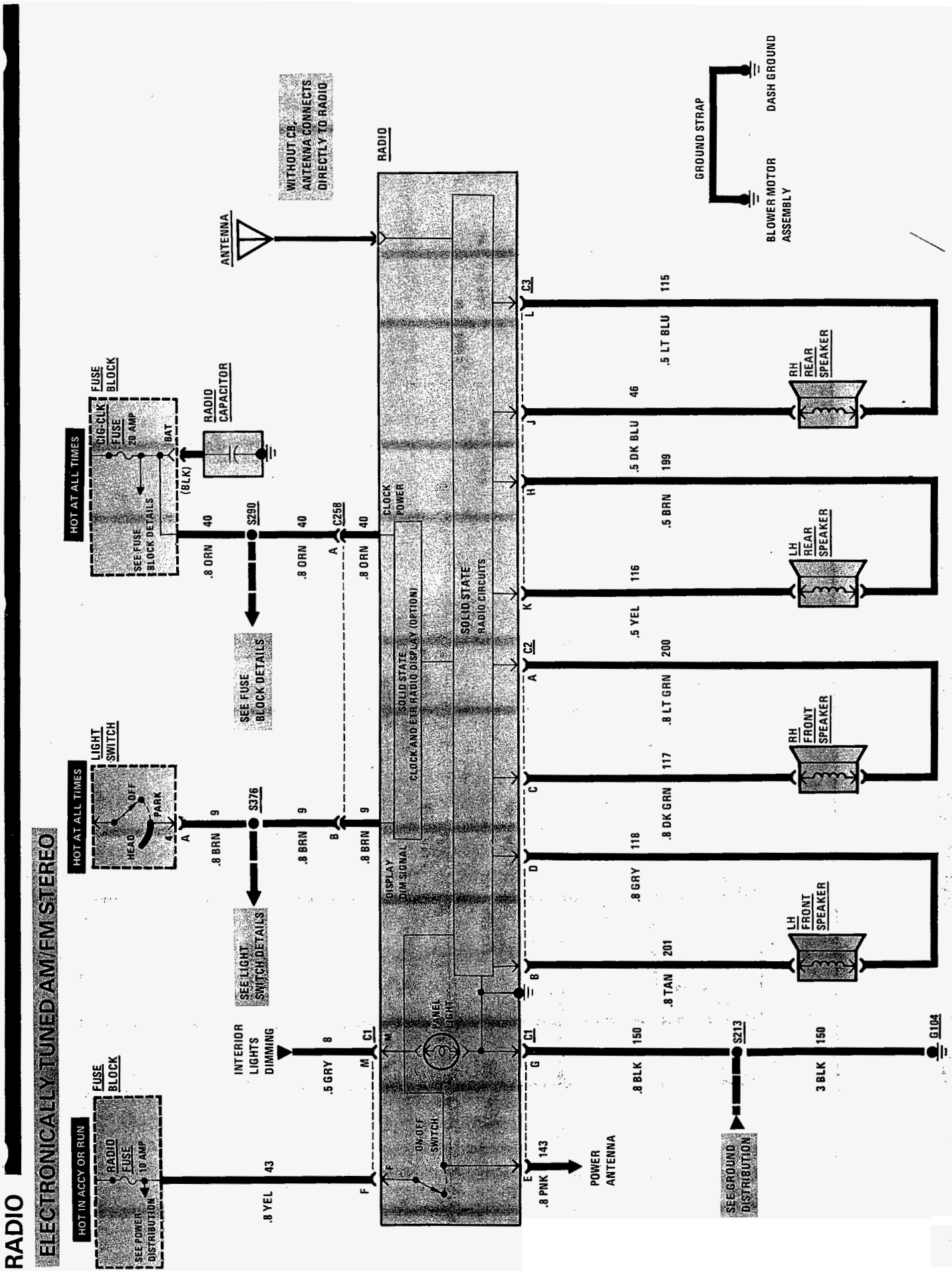

WADIO: 6 SPKWR SYSTEM

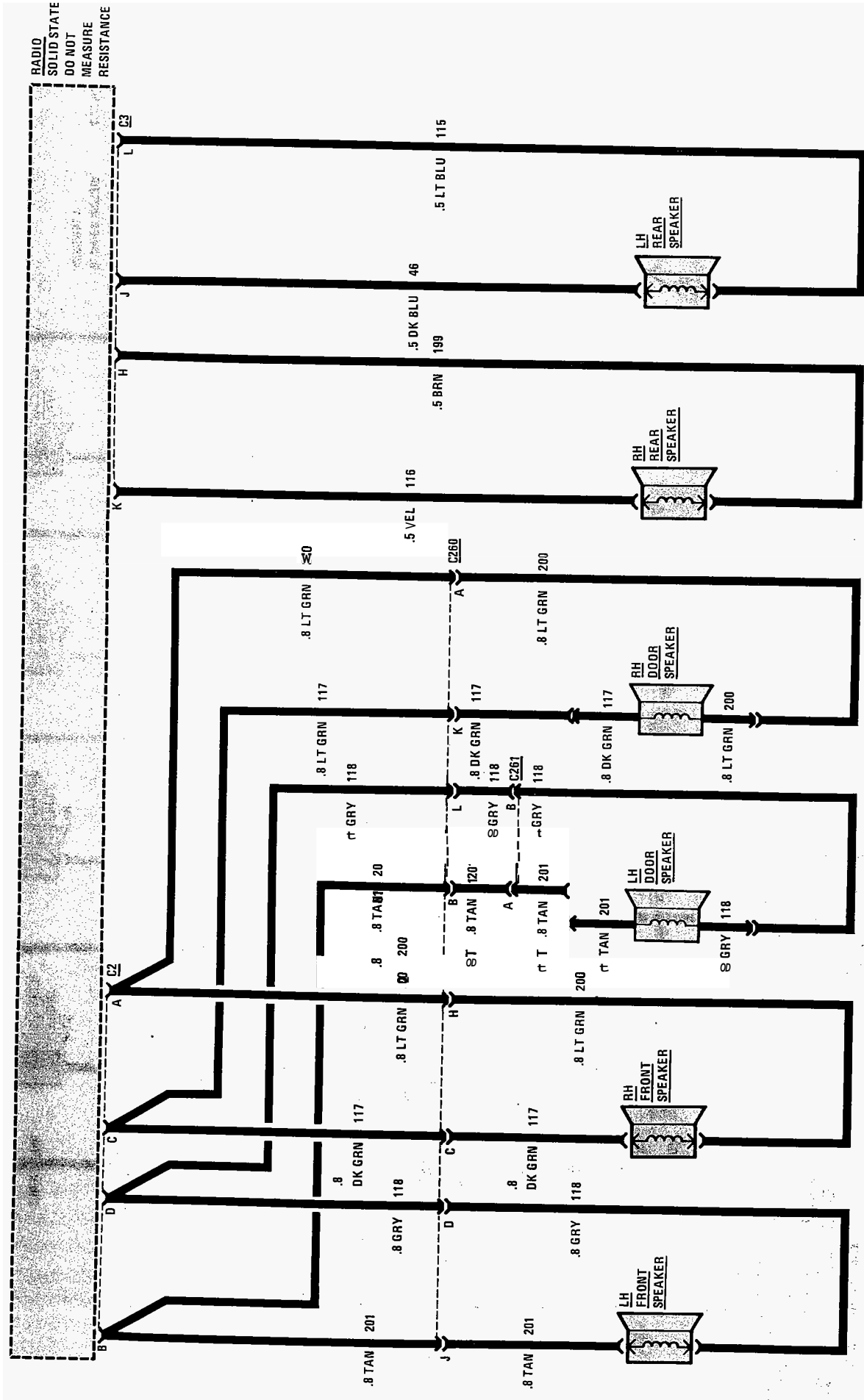

RADIO

HARNES CONNECTOR FACES

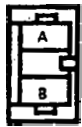

BLK

V00031.0
C258

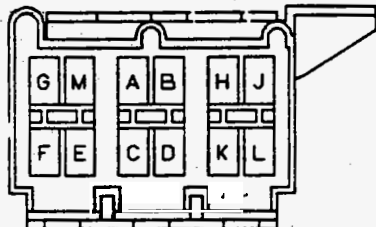

BLK.12010175
C260

COMPONENT LOCATION

Page-Figure

Fuse Block.	Under LH side of I/P.	201-12-A
Radio Capacitor	Lower LH corner of fuse block	201-1342
C258 (2 cavities)	Behind radio	201-15-A
C260 (12 cavities)	Behind radio	201-15-A
C261 (2 cavities)	Behind RH side of radio	
G104	Behind I/P, to left of steering column.	201-15-A
S213.	I/P harness, above radio.	201-16-A
S290.	I/P harness, above steering colum	201-13-B
S376.	I/P harness, above fuse block..	201-13-B

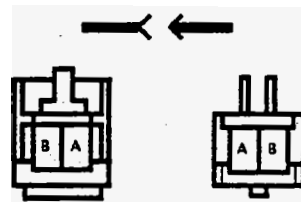

BLK

BLK

v02011.2
C261

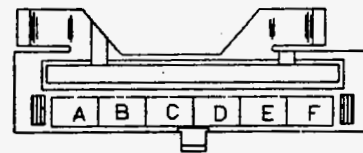

WHT 12020031
Light Switch

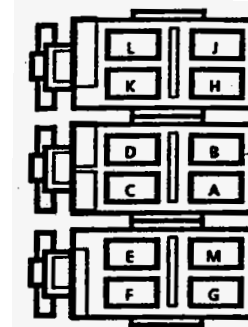

C3 BLU

C2 WHT

C1 BLK

V00010.0
Radio

TROUBLESHOOTING HINTS

- Try the following checks before doing the System Check.

RADIO

1. Check the Radio Fuse.
2. (Electronically Tuned Radio) Check the CIG-CLK Fuse by operating the Front Cigar Lighter.
3. Check that the antenna connector and coaxial cable are properly connected.
4. Adjusting the Radio controls will change the operation of the sound system. Consult the Delco Sound Service Guide for information regarding the operation of these controls.

SPEAKER

Before troubleshooting a suspect speaker, check all connections to that speaker.

NOISE

1. For proper diagnosis, take the car outside where signals are strong. Close the hood, and keep away from metal buildings or sources of radio interference.
2. Ignition noise on FM may indicate a possible defective Ignition system.
3. Coated screws or bolts can cause a poor ground condition. Scrape ground screw clean of any paint or varnish.
 - Go to System Check for a guide to normal operation.
 - Go to System Diagnosis for diagnostic tests.

SYSTEM CHECK

- Use the System Check Table as a guide to normal operation.
- Refer to System Diagnosis for a list of symptoms and diagnostic steps.

SYSTEM CHECK TABLE

	NORMAL RESULT
With the Ignition Switch in RUN, turn the Radio ON	The display comes on (Electronically Tuned Radio) The Digital Clock operates Sound comes from all four speakers
Operate the Radio controls	Consult the Delco Sound Service Guide for information regarding the operation of the controls
Turn Headlight Switch to PARK	The Panel Light comes on (Electronically Tuned Radio) The Digital display dims

- Refer to System Diagnosis when a result is not normal.

SYSTEM DIAGNOSIS

- Do the tests listed for your symptom in the Symptom Table below.
- Tests follow the Symptom Table.

SYMPTOM TABLE

SYMPTOM	FOR DIAGNOSIS
Radio does not appear to work (no display lights, no sound)	Do Test A
Clock (if equipped) does not operate	Do Test B
Panel Light does not come on	Do Test C
Display Dimming function will not operate (Electronically Tuned Radio)	Do Test D
No sound or distorted sound comes from a speaker	Do Test E
Excessive noise comes from all speakers	Do Test F

RADIO

A: RADIO POWER INPUT TEST

Measure: VOLTAGE At: RADIO CONNECTOR C1 (Disconnected) Condition: • Ignition Switch: RUN		
Measure Between	Correct Voltage	For Diagnosis
F (YEL) & Ground	Battery	See 1
F (YEL) & G (BLK)	Battery	See 2
<ul style="list-style-type: none"> If the voltages are correct, remove Radio for service. <ol style="list-style-type: none"> Check YEL (43) wire for an open. Check BLK (150) wire for an open to ground. 		

B: CLOCK TEST

Measure: VOLTAGE At: RADIO CONNECTOR C258 (Disconnected)		
Measure Between	Correct Voltage	For Diagnosis
A (ORN) & Ground	Battery	See 1
<ul style="list-style-type: none"> If the voltage is correct, remove Radio for service. <ol style="list-style-type: none"> Check ORN (40) wire for an open (see schematic). 		

C: PANEL LIGHT TEST

Measure: VOLTAGE At: RADIO CONNECTOR C1 (Disconnected) Conditions: • Light Switch: PARK • Dimming Switch: HI		
Measure Between	Correct Voltage	For Diagnosis
M (GRY) & Ground	10Volts	See 1
<ul style="list-style-type: none"> If the voltage is correct, remove Radio for service. <ol style="list-style-type: none"> Check GRY (8) wire for an open (see schematic). 		

D: DISPLAY DIMMING TEST

Measure: VOLTAGE At: RADIO CONNECTOR C258 (Disconnected) Condition: • Light Switch: PARK		
Measure Between	Correct Voltage	For Diagnosis
B (BRN) & Ground	Battery	See 1
<ul style="list-style-type: none"> If the voltage is correct, remove Radio for service. <ol style="list-style-type: none"> Check BRN (9) wire for an open (see schematic). 		

Action	Correct Result	For Diagnosis
Connect Ohmmeter across speaker terminals	Speaker "pops"	See 1

Measure: A C Voltage At: RADIO OUTPUT FOR SUSPECT SPEAKER Conditions: • Ignition Switch: RUN • Radio: ON (High Volume)		
Action	Correct Voltage	For Diagnosis
Connect volt-meter across outputs for suspect speaker with Radio tuned to a strong signal	Varying around 1 Volt AC	See 1
<ul style="list-style-type: none"> If the voltage is correct, repair the wires between the Radio and the suspect speaker. <ol style="list-style-type: none"> Remove Radio for service. 		

(Continued on next page)

(Continued from previous page)

F: NOISE DIAGNOSIS TEST

Unplug the Antenna at the back of the Radio.

- If the noise disappears, it was being picked up by the Antenna. Consult the Delco Sound Service Guide for Antenna noise diagnosis.
- If the noise persists, it is coming in the Radio wiring. Refer to the following chart for a possible cause and corrective action.

SYMPTOM	POSSIBLE CAUSE	REPAIR ACTION
Harsh popping noise that changes with engine rpm	Ignition noise	Perform the steps under Ignition Noise p. 150-7.
High whine (like a siren) rpm	Generator noise	Add filter package 1224205 to 14 volt and/or memory lead to the Radio. See Fig. 2, p. 150-7. By-pass the generator output and/or the bi-field wire of the generator with 250 MFD 100 v capacitor. See Fig 3, p. 150-7. Exchange the defective Radio with a good Radio. If the noise disappears, send the defective Radio for repair. Install a dedicated ground strap on the Radio. See Fig. 1, p. 150-7. Run a direct wire from battery + to generator. Replace generator.
Noise occurs only when an accessory is on	Condition in that accessory	Install filter package 1224205 in the power lead(s) to that accessory. See Fig. 2, p. 150-7. Install a .5 MFD by-pass capacitor at the power lead to that accessory. Consult Delco Sound Service Guide.
All stations weak, noisy, both AM and FM	Defective antenna or lead-in wire	Temporarily replace the antenna with another one. Repair/replace the defective one if the radio reception improves. Check at the antenna Coax Lead-In and the connector.
AM only, weak, noisy	AM alignment	Remove Radio for repair.
FM only, weak, noisy	FM alignment	Remove Radio for repair.
Noise present with engine not running	ECM or Digital Cluster	Install filter package 1224205 in the power leads to the Electronic Control Module (ECM) Instrument Panel Digital Cluster.
Noise that stops when antenna is unplugged from back of Radio	Antenna noise	Replace defective antenna with a good antenna. If noise disappears repair or replace the defective antenna. Check antenna ground, Coaxial Cable Braid, and grounds at connectors. If noise persists with replacement antenna, the problem must be repaired at the source of noise (generator, ignition system, accessory, etc.). See the Delco Sound Service Guide for noise "snifting" procedures.

For more detailed noise repair procedures consult the Delco Sound Service Guide. Service procedures are given for:

- Accessory noises
- CB antennas and noise
- Computer noise
- Windshield antennas
- Shielding of wiring and components
- Locating vehicle noise

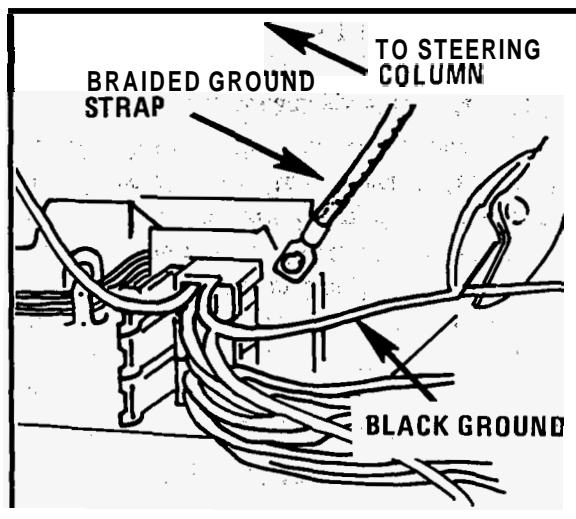

Figure 1 - Cut the black (ground) wire from the black plug at the back of the Radio and run a braided ground strap from the case of the Radio to good, unpainted body ground.

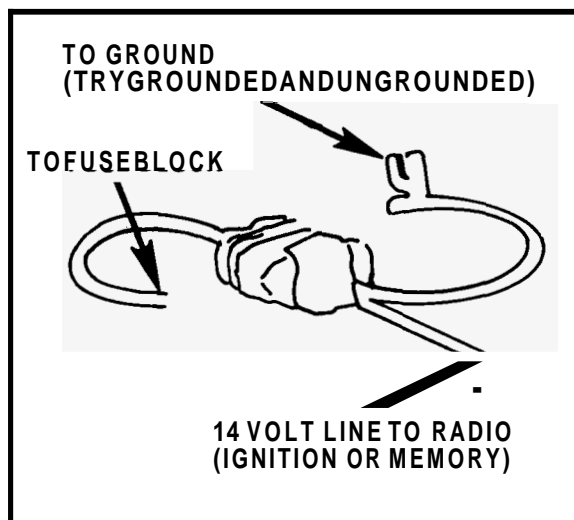

Figure 2 - Install a 1224205 filter package.

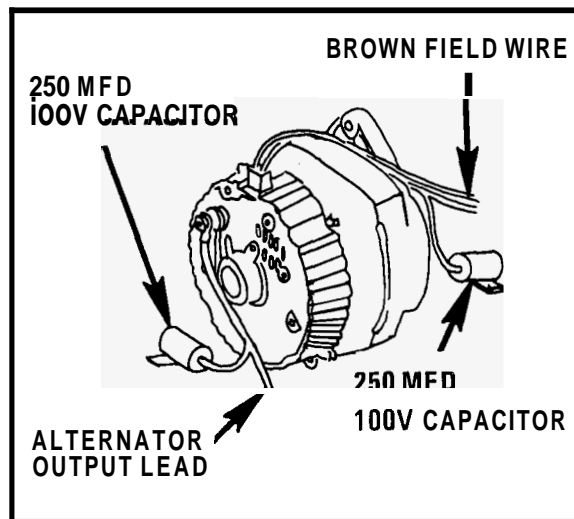

Figure 3 - Install a 250 MFD 100V capacitor on the alternator output lead and/or the brown field wire of the alternator to ground.

IGNITION NOISE

Try the following fixes in the given order.

1. Check for loose or defective spark plug wire.
2. Check for defective spark plug.
3. Move all wiring away from Ignition System and spark plug wires.
4. Reroute spark plug wires laying against anything that could possibly transmit noise to the Radio (car wiring or sensor leads that travel into the passenger compartment).
5. Replace distributor cap and rotor.
6. Check the ground from engine to firewall; install a braided ground strap if necessary.
7. Install a braided ground strap on the hood.
8. Check heater core ground; clean or install braided ground strap if necessary.
9. Check air conditioner accumulator ground; clean or install a braided ground strap if necessary.

(Continued on next page)

(Continued from previous page)

CIRCUIT OPERATION

The Radio Fuse provides main power to the Radio and to the Power Antenna. With the Ignition Switch in ACCY or RUN, voltage is applied through the Radio Fuse and the YEL wire to the ON-OFF switch in the Radio. The circuit is grounded at G104. With the ON-OFF switch closed, voltage is applied through the Radio Fuse, Radio switch (Power Antenna), and the Solid State Radio circuits to ground.

Two wires connect each speaker to the Radio.

The ETR Radio has two inputs that other models do not have: Dim Display Signal and Battery Power.

The ETR model is an AM/FM radio that changes stations electronically. The frequencies of preselected stations can be stored in the electronic memory. The ETR model also provides a digital display of time or station frequency. As in other models, the Light Switch controls panel light dimming. In the ETR model, dimming is also controlled by the Radio itself by means of the Dim Display Input Signal.

The ETR model's clock memory and Radio memory functions are powered at all times through the CIG-CLK Fuse. If power to the ETR model is cut off by disconnecting the Battery, for example, the operator must reset the memory functions when power is restored.

BLANK

POWER ANTENNA

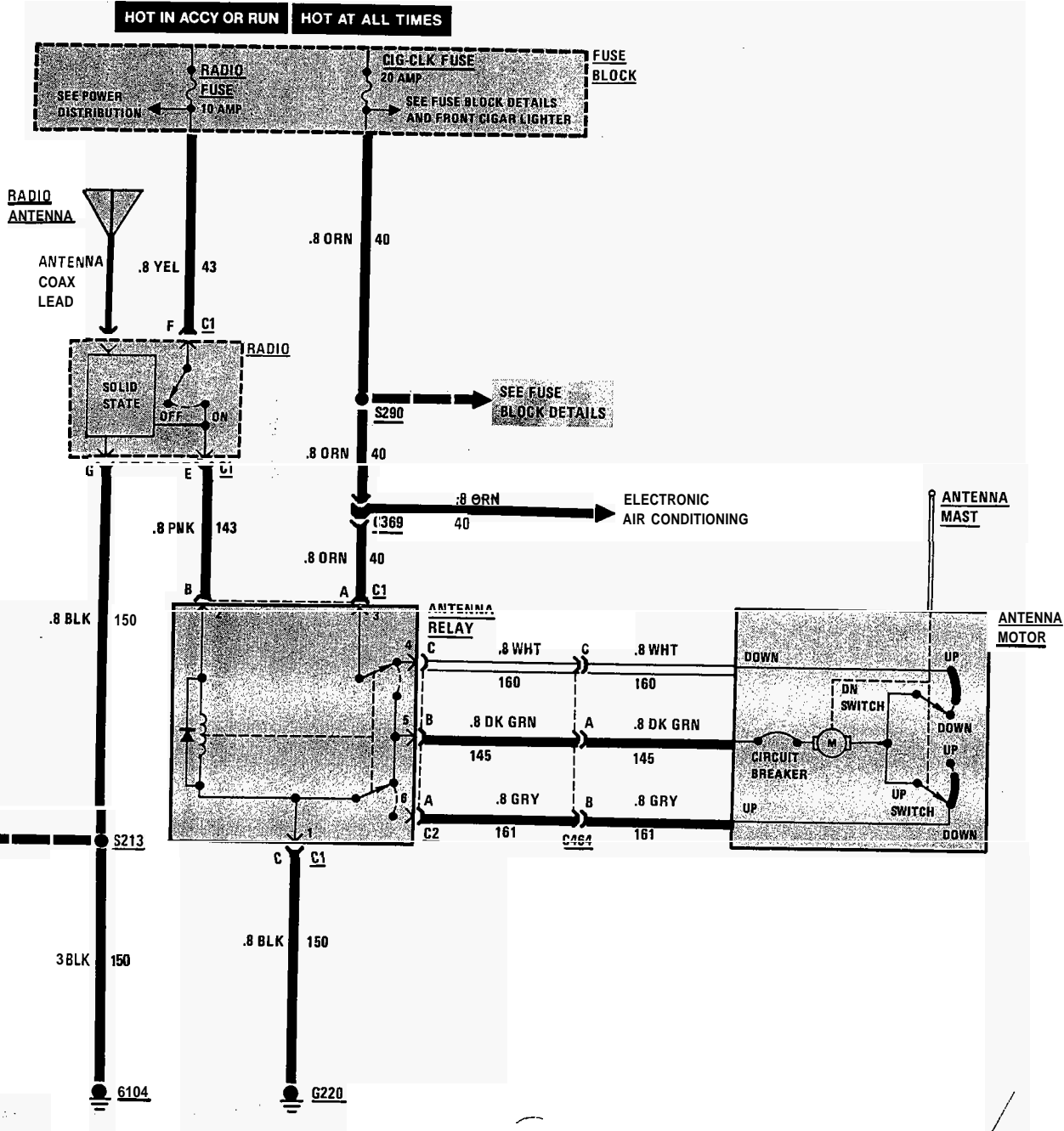

POWER ANTENNA

HARNES CONNECTOR FACES

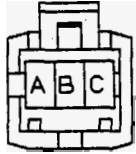

BLK 8917543
Antenna Motor (C464)

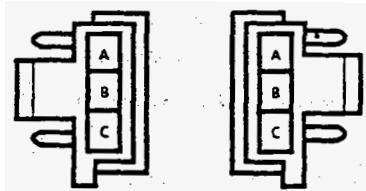

C1 BLK C2 GRY
V00011.0
Antenna Relay

COMPONENT LOCATION

Page-Figure

Antenna Motor	Inside RH front fender	201-23-E
Antenna Relay	Behind RH side of I/P, right of glove box	201-17-D
Fuse Block.	Under LH side of I/P.	201-12-A
C369 (1 cavity)	Behind I/P, near RH shroud.	201-16-C
C464 (3 cavities)	RH rear of engine compartment, near power antenna motor.	201-23-F
G104	Behind I/P, to left of steering column.	201-15-A
G220	Bottom RH side of I/P, underneath glove box. .	201-17-D
S213.	I/P harness, above radio.	201-16-A
S290.	I/P harness, above steering column	201-15-A

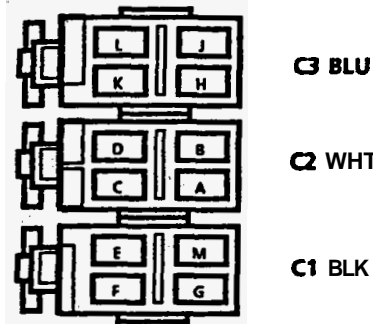

V00010.0
Radio

TROUBLESHOOTING HINTS

- Try the following checks before doing the System Check.
- 1. Check the Radio Fuse by turning the Radio ON and noting that the display lights come on.
- 2. Check the CIG/CLK Fuse by operating the Front Cigar Lighter.
- 3. Power Antenna goes up or down part way.
 - Check Power Antenna mast for bent condition or dirt. If mast is dirty and/or bent, straighten the mast and clean off the dirt. Lube with light oil and check operation. If the mast is straight and clean, replace the Antenna Motor.
- Go to System Check for a guide to normal operation.
- Go to System Diagnosis for diagnostic tests.

SYSTEM CHECK

- Use the System Check Table as a guide to normal operation.

SYSTEM CHECK TABLE

With the Ignition Switch in RUN, turn Radio ON	NORMAL RESULT
Turn Radio OFF	Antenna mast extends to full height Radio receives strong broadcast signals
Turn Radio OFF	Antenna retracts into fender

- Refer to System Diagnosis when a result is not normal.

SYSTEM DIAGNOSIS

- Make the measurements given in the following tables if the Antenna does not operate.

Measure: VOLTAGE At: ANTENNA RELAY CONNECTOR C1 (Disconnected) Conditions: • Ignition Switch: RUN • Radio: ON		
Measure Between	Correct Voltage	For Diagnosis
A (ORN) & Ground	Battery	See 1
A (ORN) & C (BLK)	Battery	See 2
B (PNK) & Ground	Battery	See 3
<ul style="list-style-type: none"> • If all voltages are correct, go to Table 2. 1. Check ORN (40) wire for an open. 2. Check BLK (150) wire for an open to ground. 3. Check PNK (143) wire for an open to the Radio. Remove the Radio for repair if wire is OK (see schematic). 		

A: ANTENNA DOES NOT OPERATE (TABLE 2)

Connect: FUSED JUMPERS At: ANTENNA RELAY CONNECTOR SC1 & C2 (Disconnected)		
Jumper Between	Correct Result	For Diagnosis
C1/A (ORN) to C2/B (DK GRN) and C2/A (GRY) to C1/C (BLK)	Antenna Mast Extends	See 1
C1/A (ORN) to C2/C (WHT) and C2/B (DK GRN) to C1/C (BLK)	Antenna Mast Retracts	See 1
<ul style="list-style-type: none"> • If all results are correct, replace the Antenna Relay. 1. Reconnect Antenna Relay connectors and go to Table 3. 		

**A: ANTENNA DOES NOT OPERATE
(TABLE 3)**

Measure: VOLTAGE At: ANTENNA MOTOR CONNECTOR C464 (Disconnected) Conditions: <ul style="list-style-type: none"> • Ignition Switch: RUN • Radio: ON 		
Measure Between	Correct Voltage	For Diagnosis
A (DK GRN) & Ground	Battery	See 1
A (DK GRN) & B (GRY)	Battery	See 2
<ul style="list-style-type: none"> • Turn the Radio OFF. 		
C (WHT) & Ground	Battery	See 3
<ul style="list-style-type: none"> • If the voltages are correct, replace the Antenna Motor. <ol style="list-style-type: none"> 1. Check DK GRN (145) wire (see schematic). 2. Check GRY (161) wire (see schematic). 3. Check WHT (160) wire (see schematic). 		

When the Radio or ignition is turned off, the circuit through the Antenna Relay coil opens. The contacts open to the position shown in the schematic, applying battery voltage to the WHT wire. The DK GRN wire is now grounded. Since the DN Switch at the Antenna is now making contact to the WHT wire, the voltage to the motor has reversed polarity. It runs in the opposite direction and drives the antenna down. At the end of the travel, the DN Switch opens the circuit. Both sets of switches are now in the positions shown in the schematic with the Radio off and the Antenna down.

The Antenna is connected to the Radio by a coaxial cable.

CIRCUIT OPERATION

When the Radio is turned on, voltage is applied from the PNK wire to the Antenna Relay coil. The Antenna Relay contacts close, and battery voltage is supplied to the DK GRN wire and then to the Antenna Motor. The other motor terminal is grounded through the UP Switch, the GRY wire, and the relay contacts. The motor drives the Antenna up. At the end of its travel, the Up Switch opens and the motor stops.

COMPONENT LOCATION VIEWS

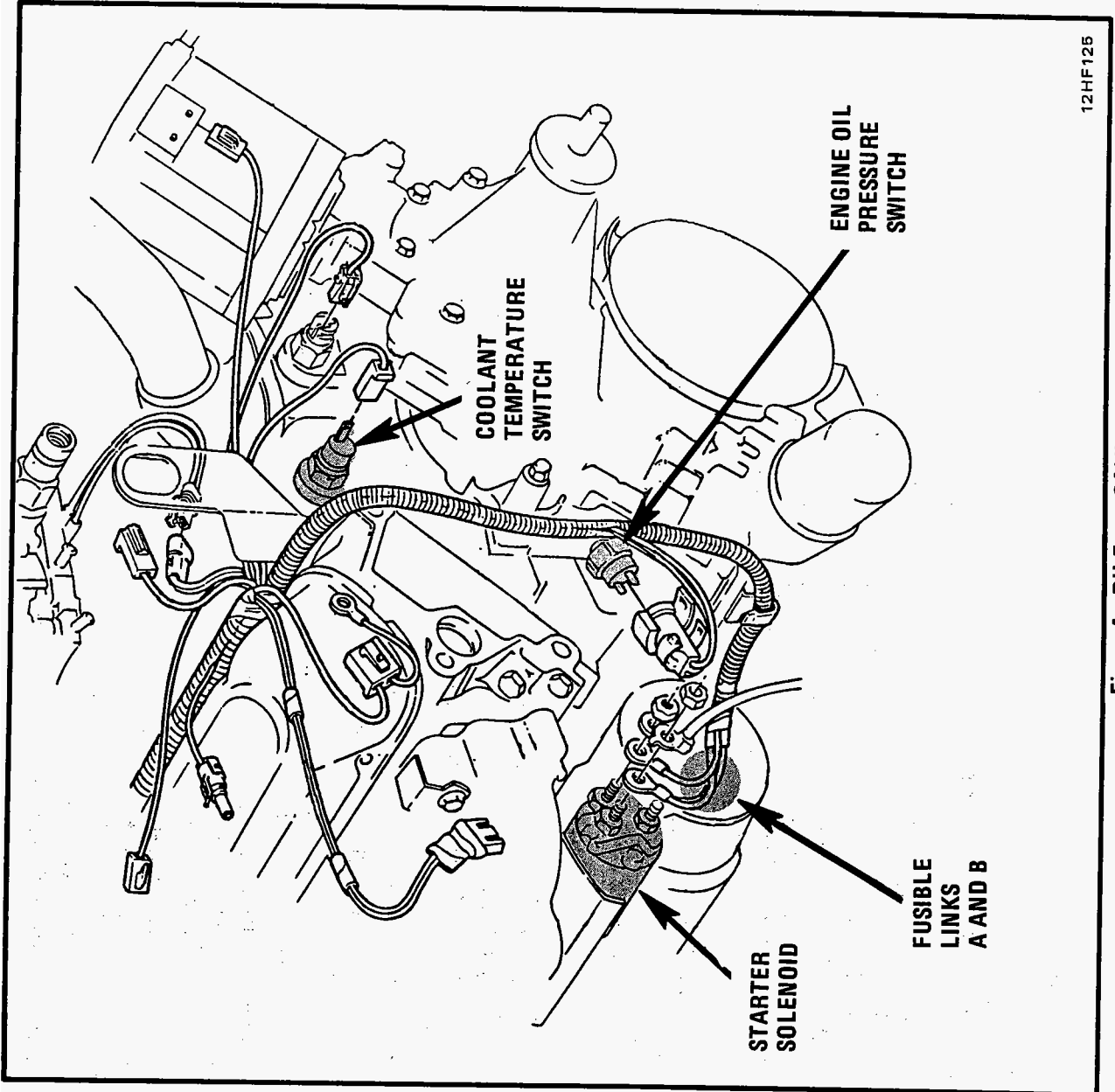

Figure A - RH Front of VIN A Engine

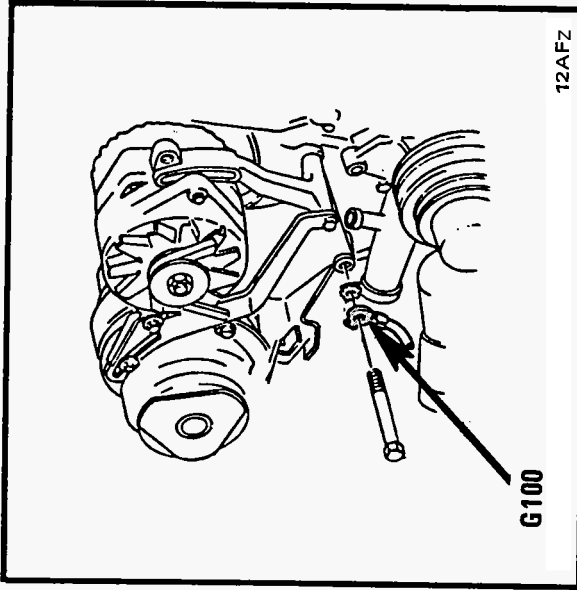

Figure B - RH Front of VIN A Engine

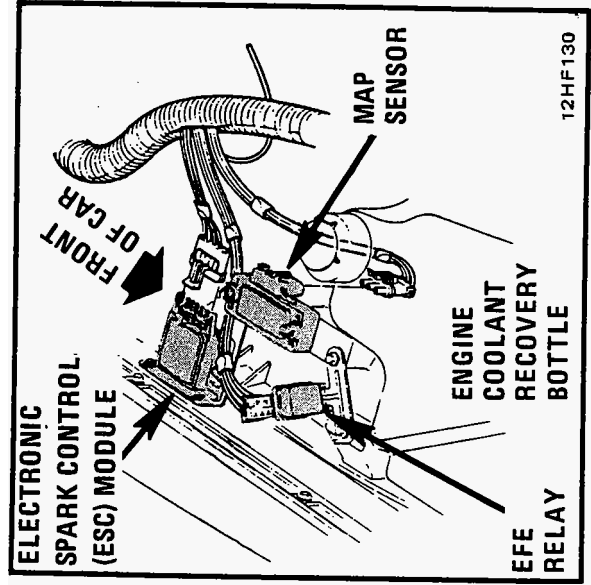

Figure C - Middle of RH Front Fender (VIN A)

COMPONENT LOCATION VIEWS

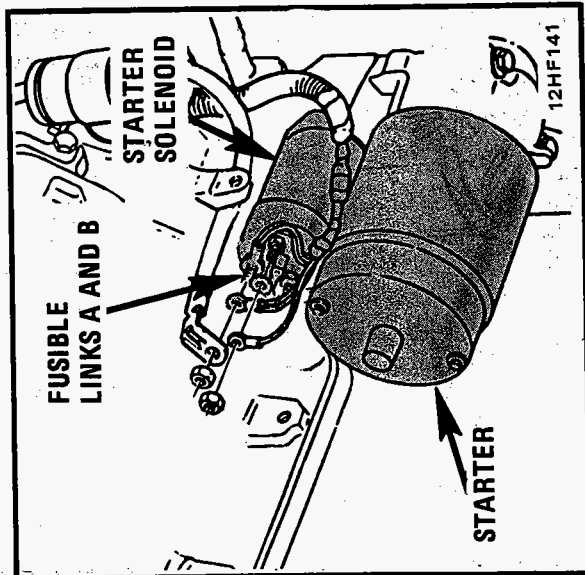

Figure A - LH Rear Of VIN Y Engine

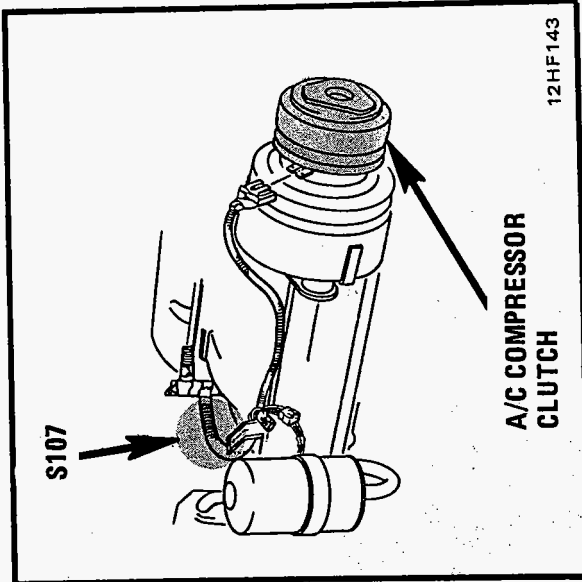

Figure C - RH Side Of VIN Y Engine

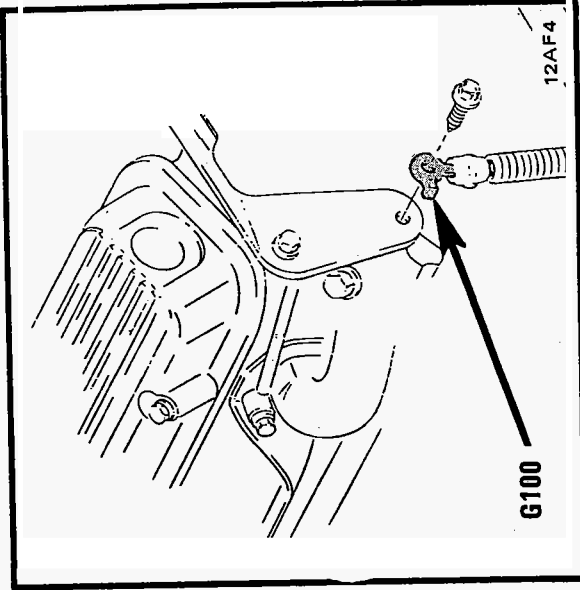

Figure E - RH Front Of VIN 7 Engine

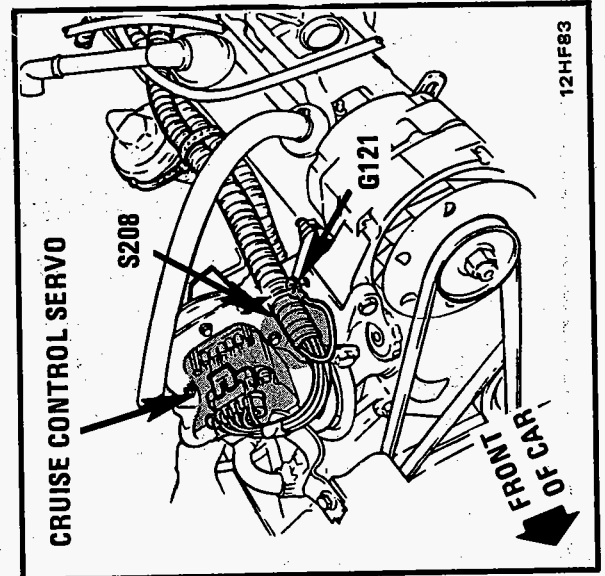

Figure B - Front Center Of Engine (VIN Y)

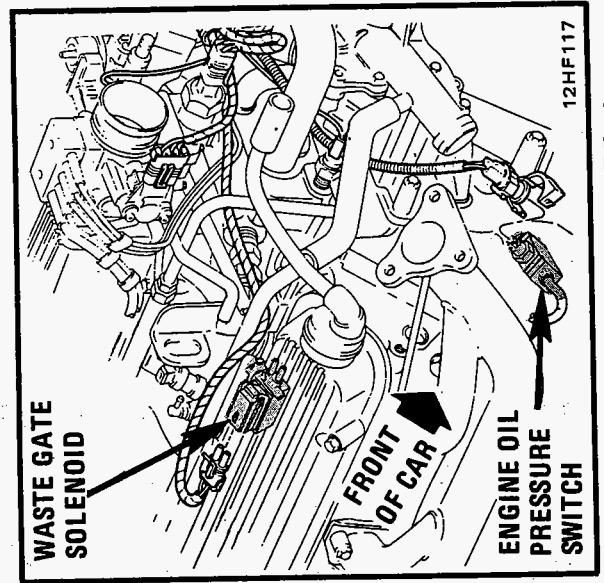

Figure D - RH Front Of VIN 7 Engine

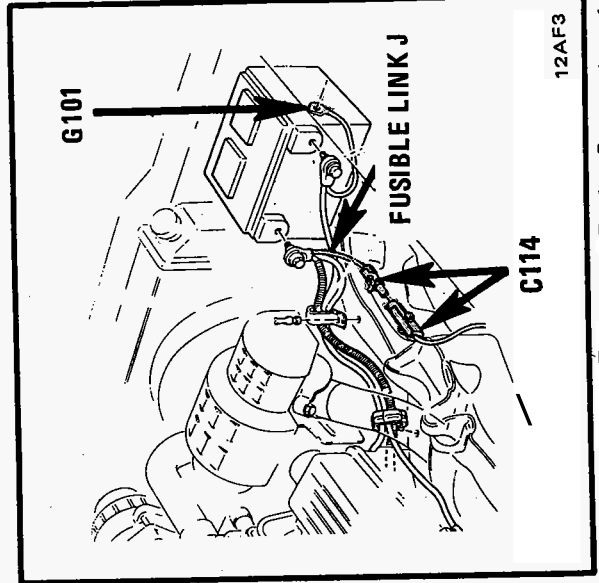

Figure F - RH Front Of VIN T Engine Compartment

COMPONENT LOCATION VIEWS

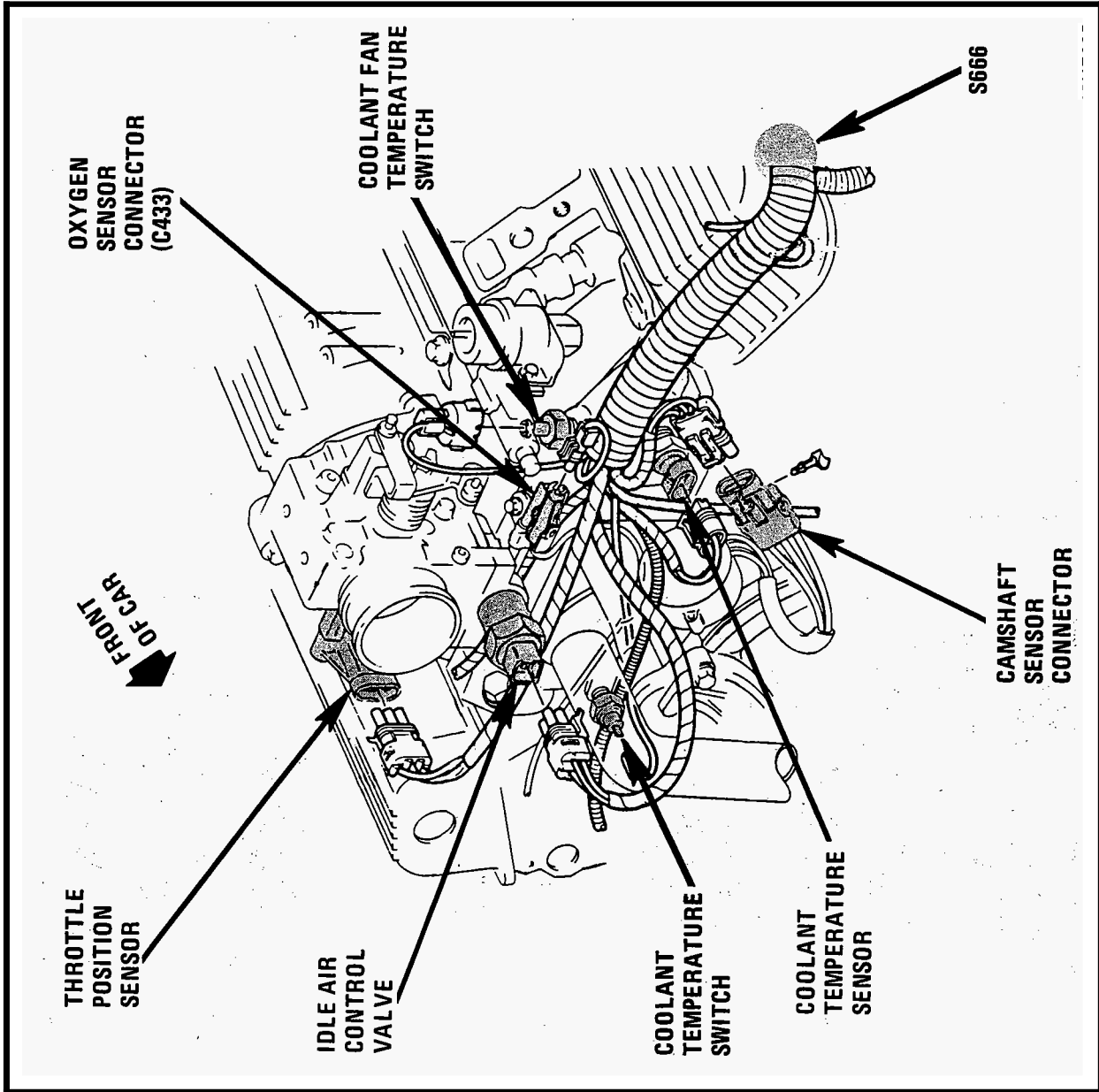

Figure A - Front Of VIN 7 Engine

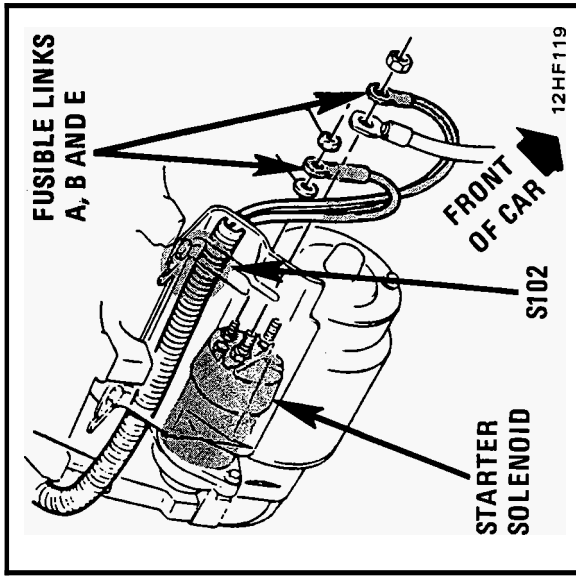

Figure B - Rear Of VIN 7 Engine

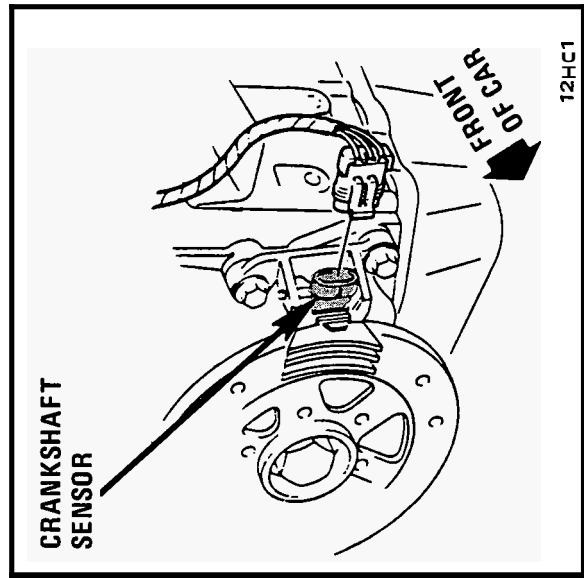

Figure C - LH Front Of VIN 7 Engine

COMPONENT LOCATION VIEWS

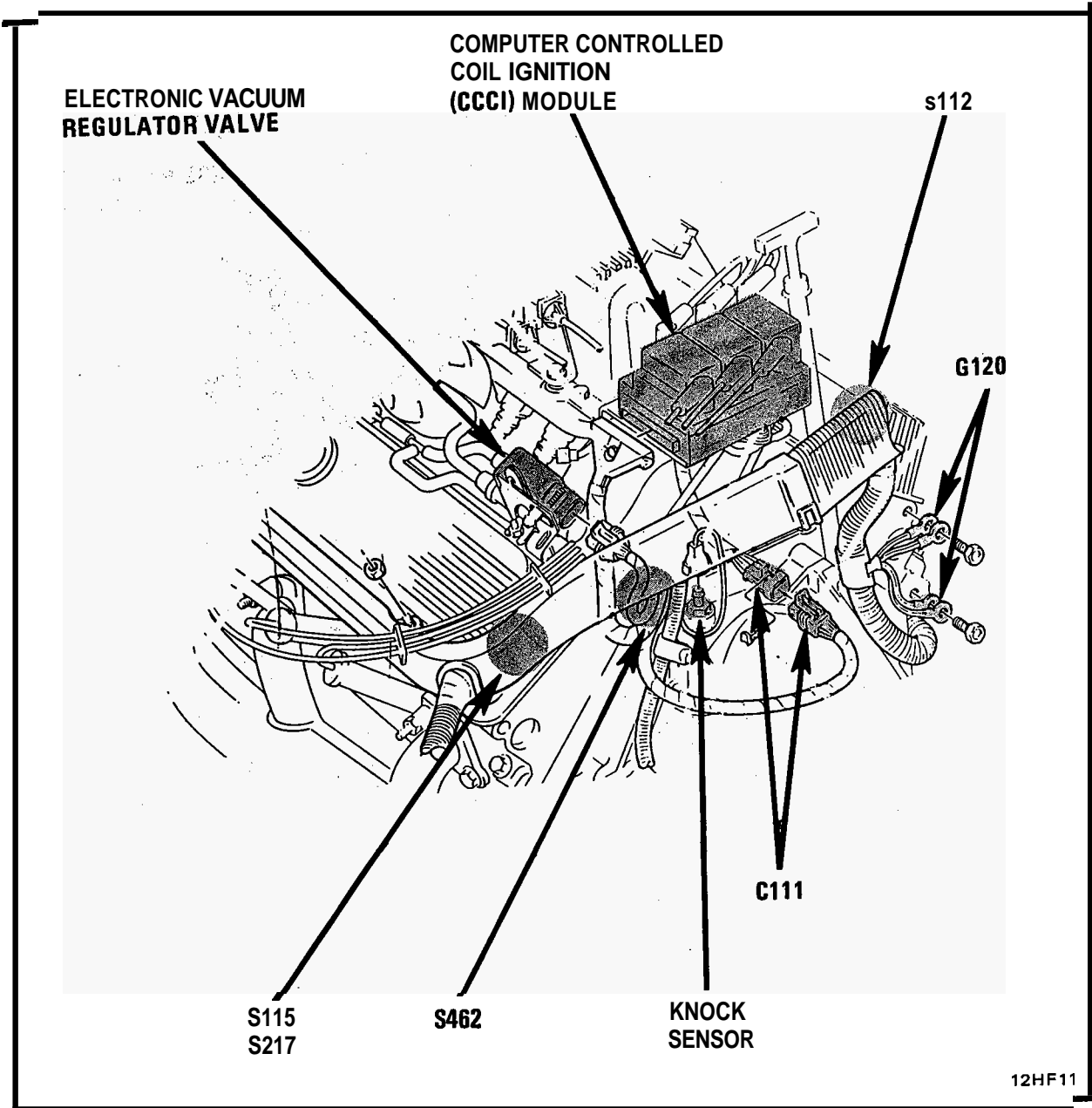

Figure A - Top Rear Of VIN 7 Engine

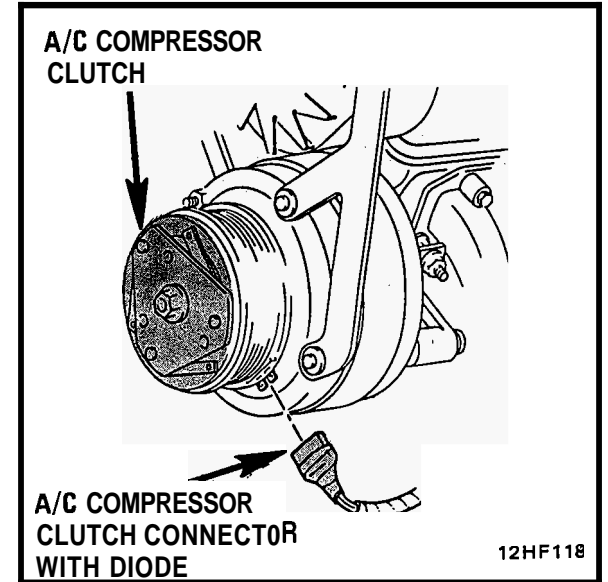

Figure B - Lower LH Front Of VIN 7 Engine

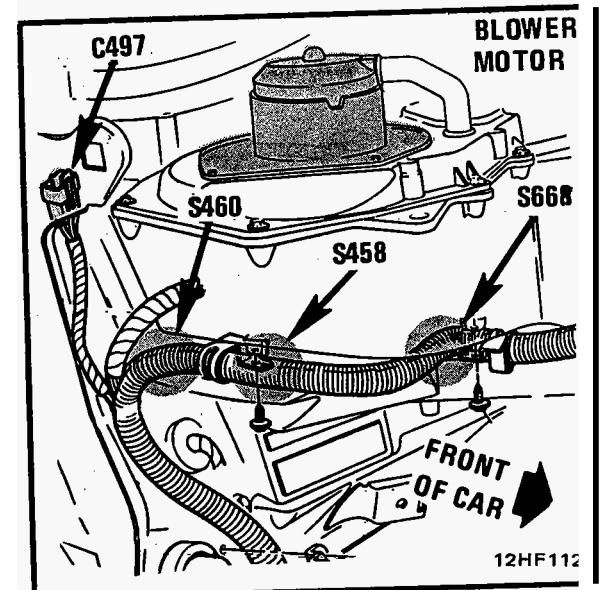

Figure C - RH Rear Corner Of VIN 7 Engine Compartment

COMPONENT LOCATION VIEWS

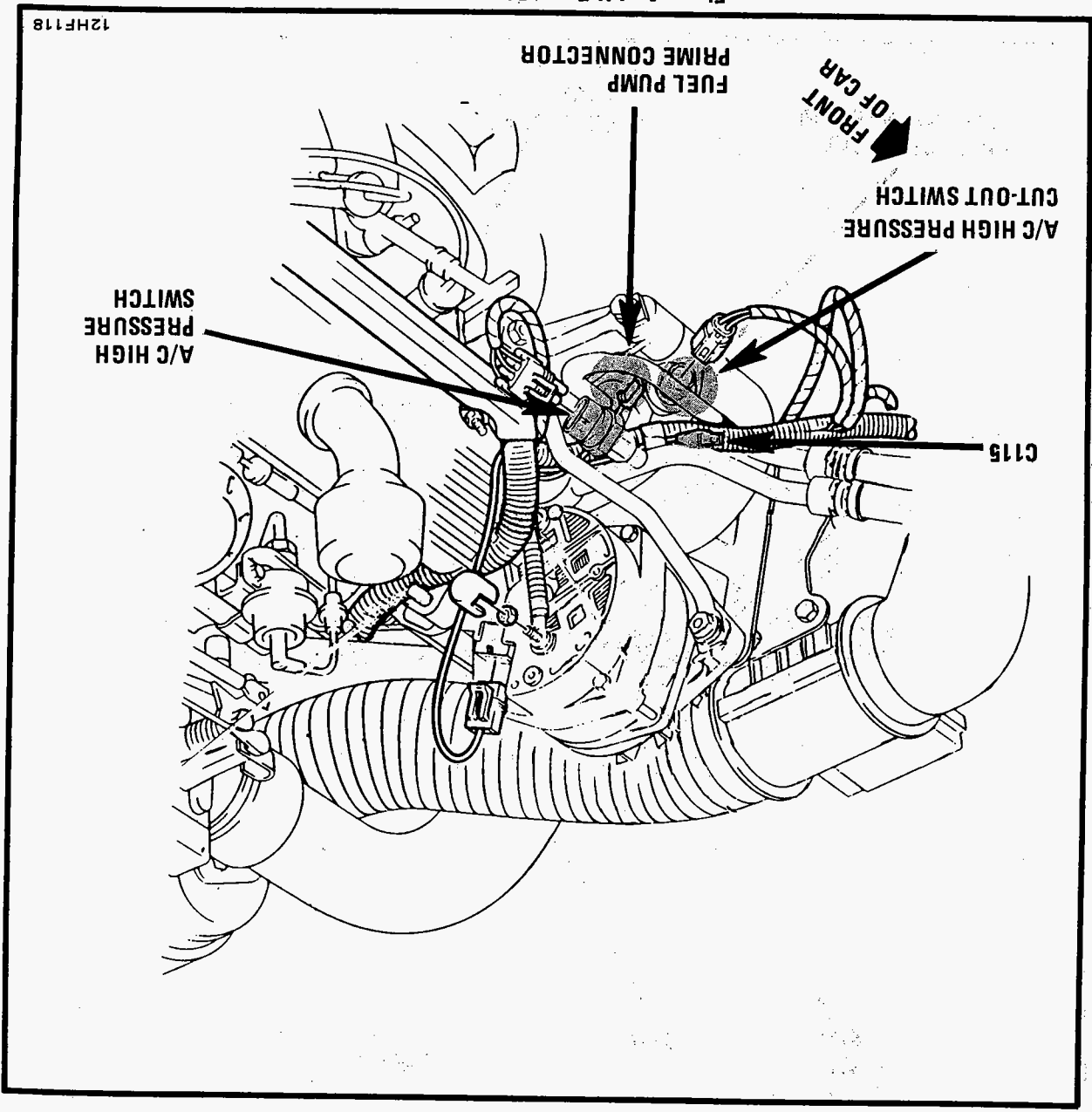

Figure A - LH Front Of VIN 7 Engine

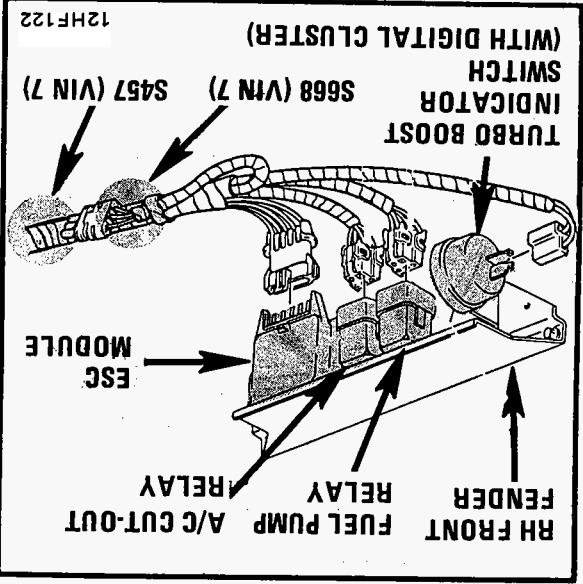

Figure B - RH Inner Fender Panel, Above Wheel Well (VIN 7)

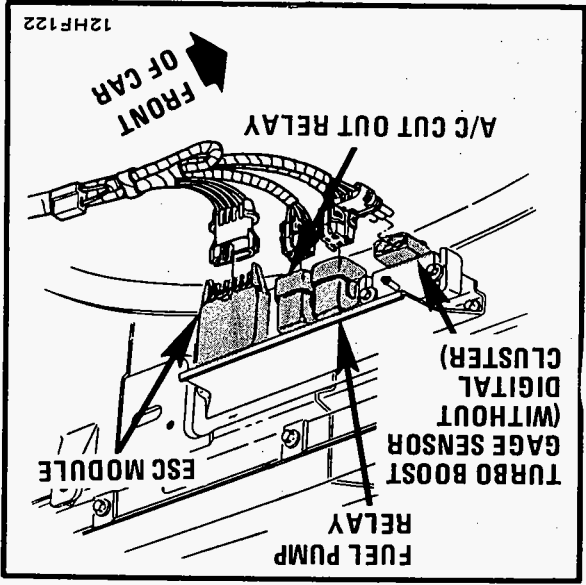

Figure C - RH Inner Fender Panel, Above Wheel Well (VIN 7)

COMPONENT LOCATION VIEWS

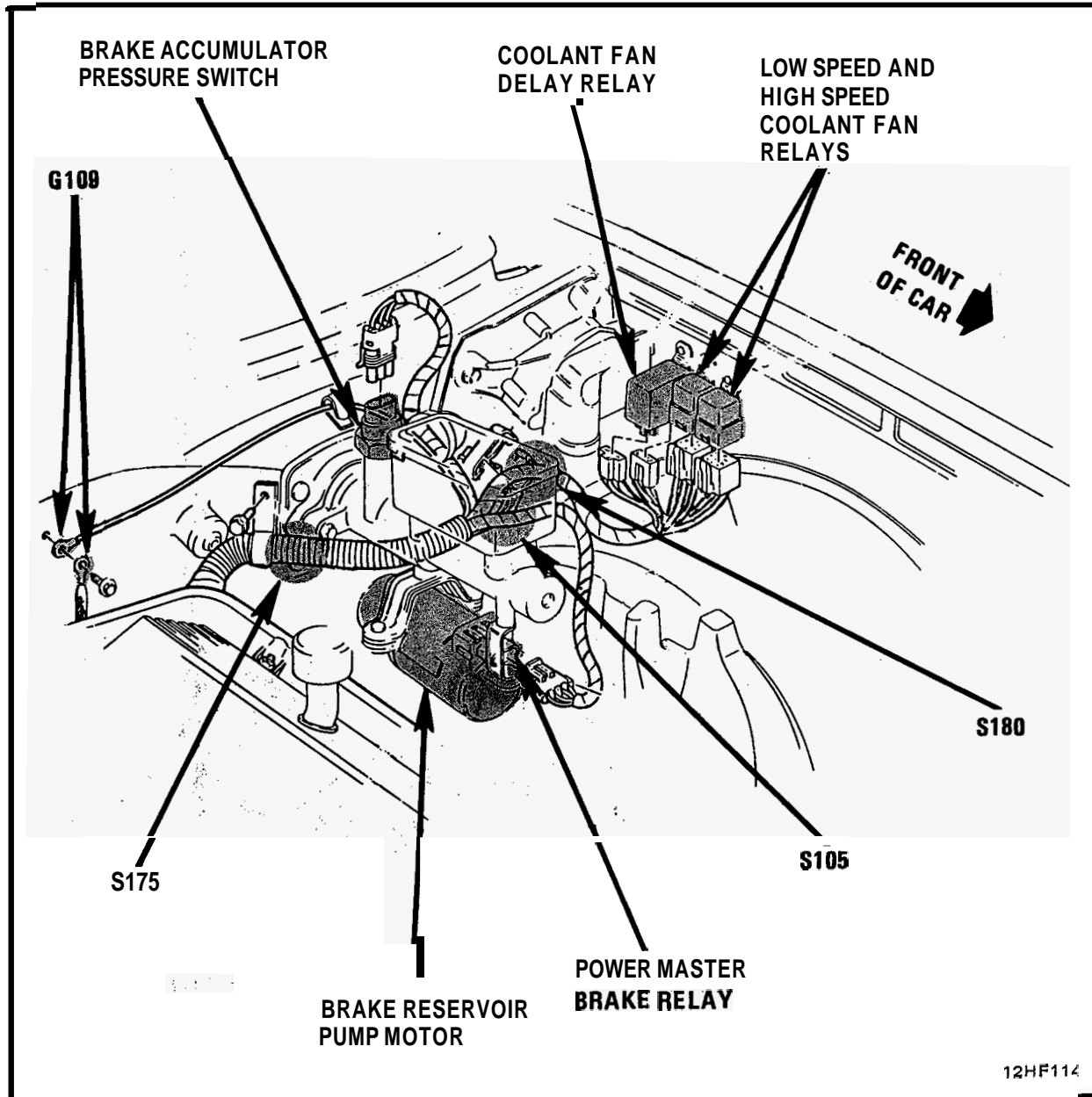

Figure A - LH Rear Of VIN 7 Engine Compartment

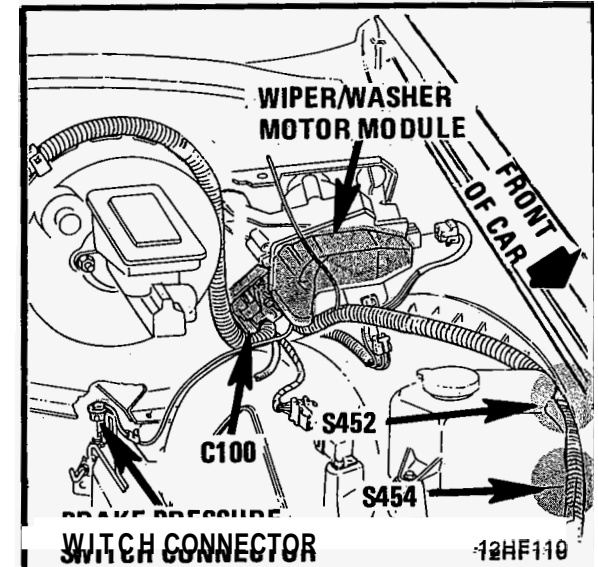

Figure B - LH Rear Of Engine Compartment

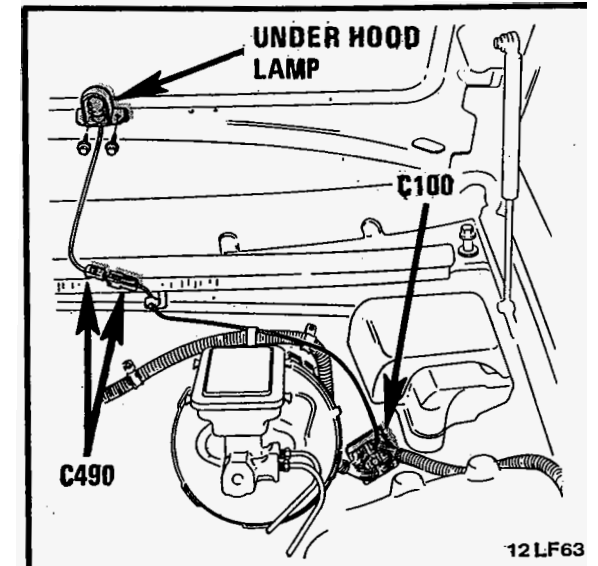

Figure C - LH Rear Corner Of Engine Compartment

COMPONENT LOCATION VIEWS

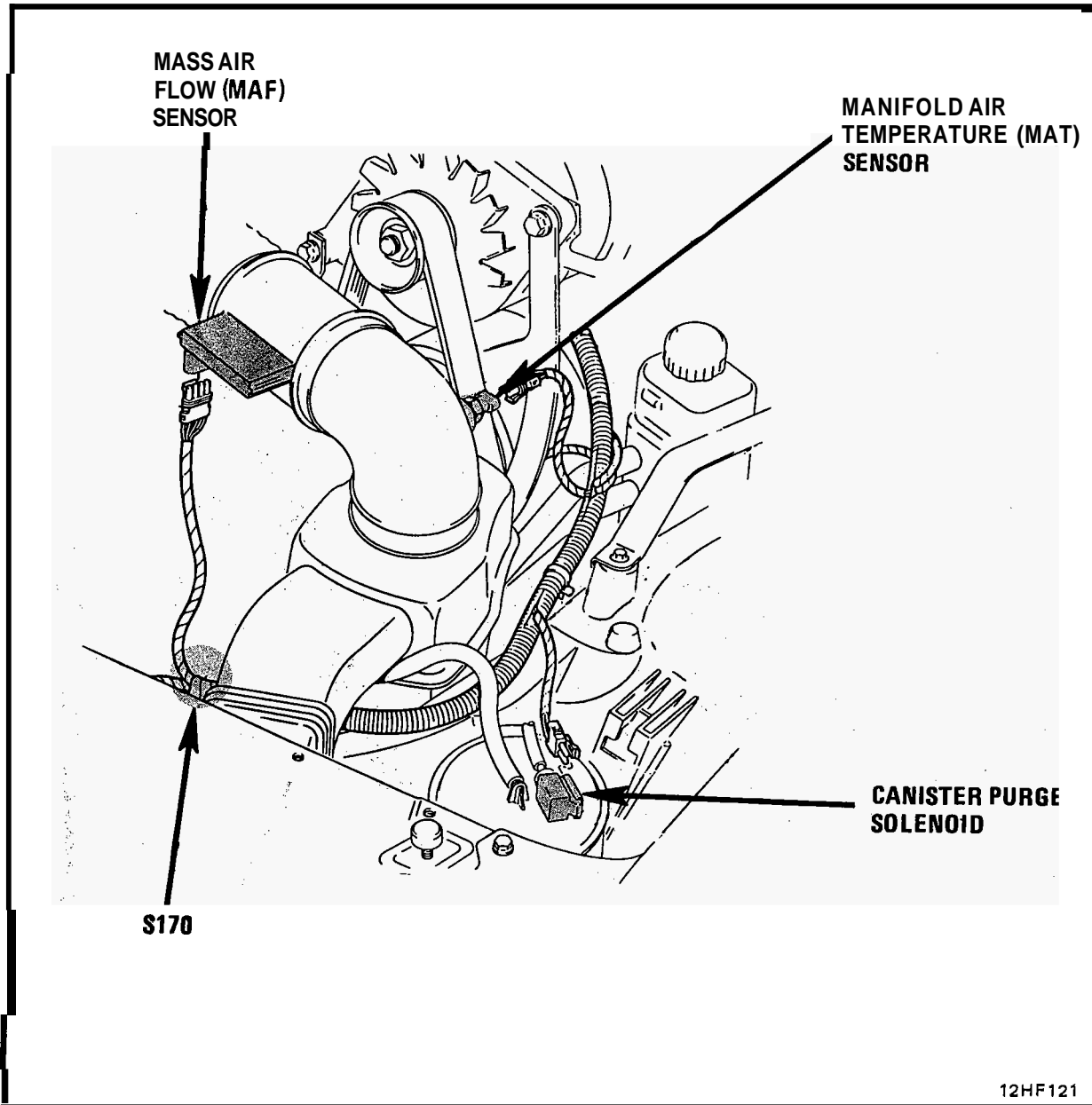

Figure A - LH Front Of VIN 7 Engine Compartment

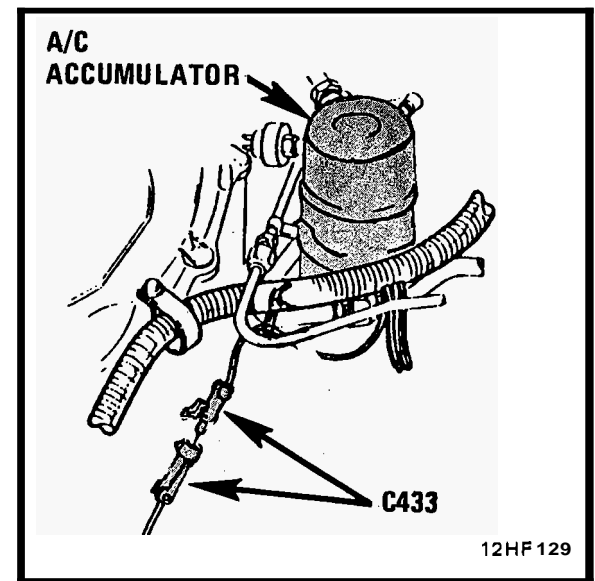

Figure B - RH Rear Of Engine Compartment

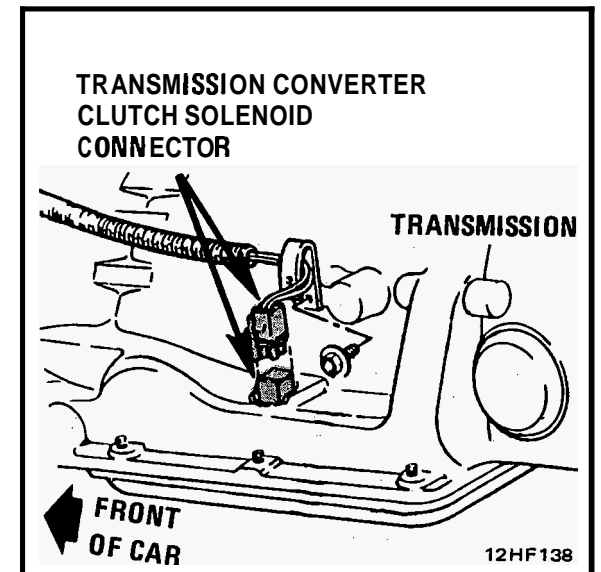

Figure C - LH Side Of Automatic Transmission

COMPONENT LOCATION VIEWS

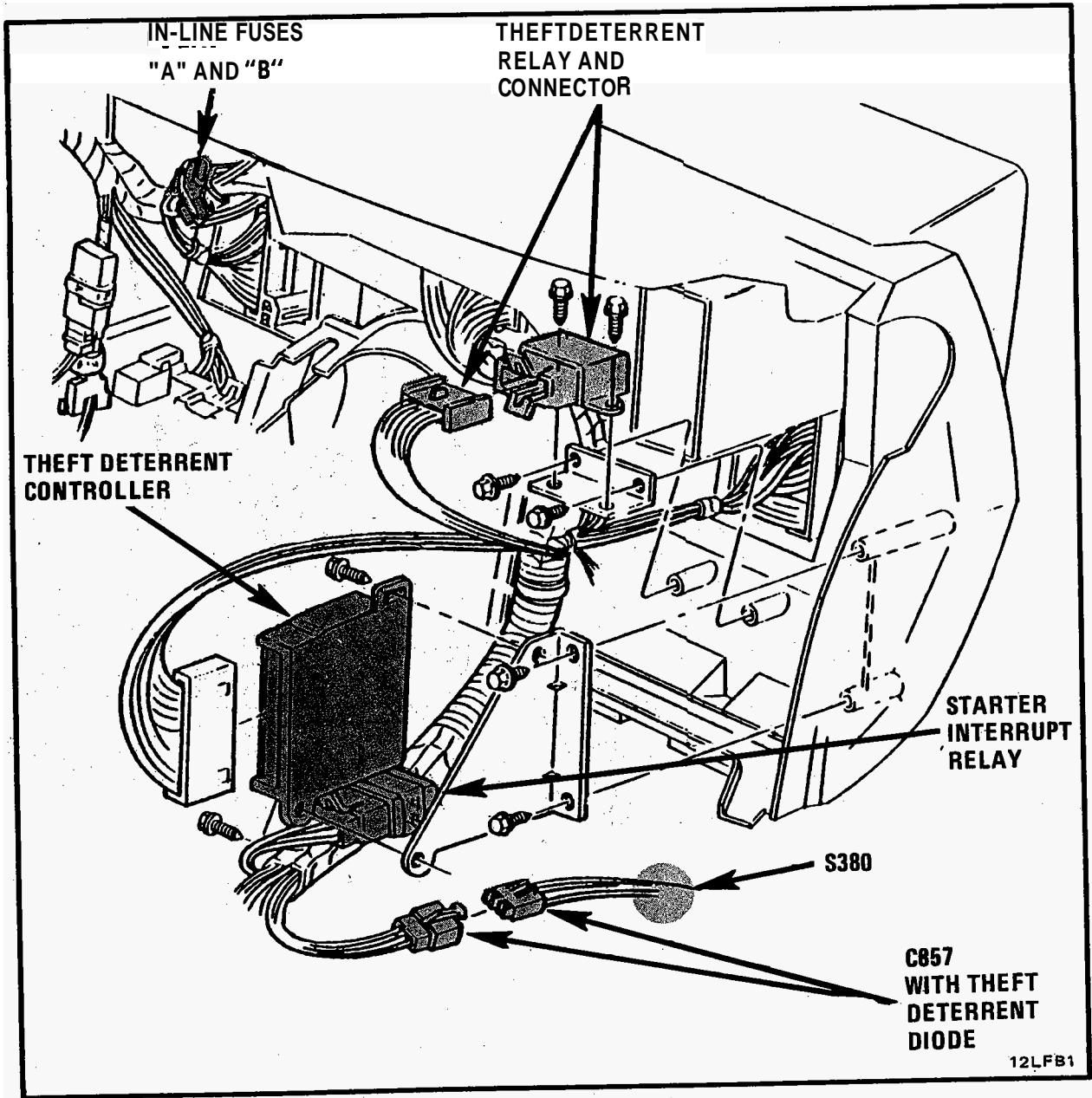

Figure A - Behind LH Side Of I/P

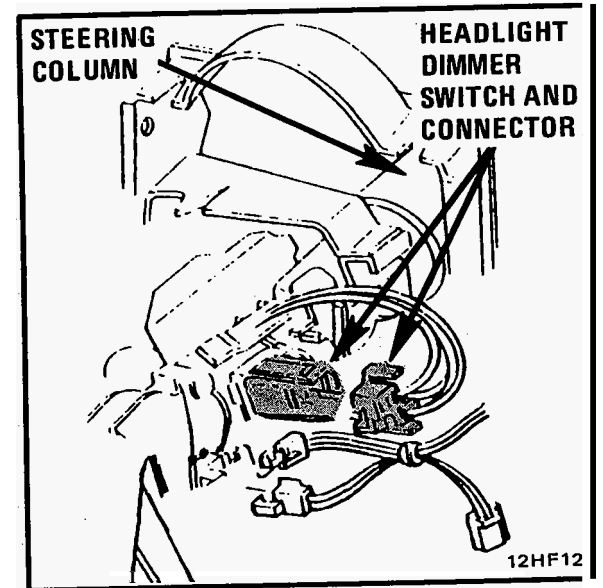

Figure B - LH Side Of Steering Column

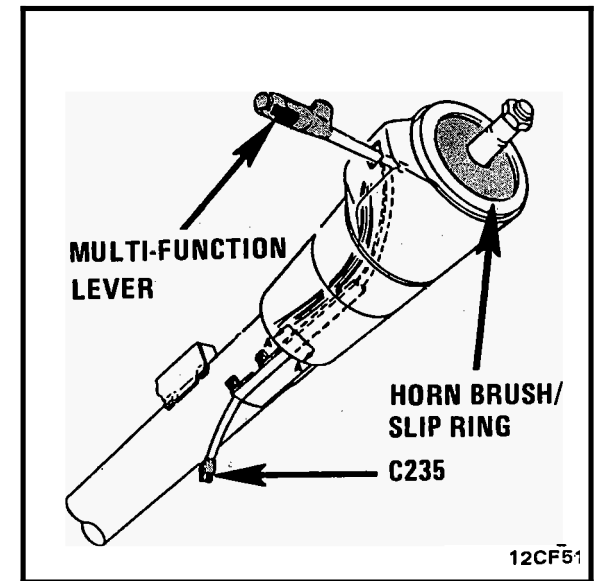

Figure C - LH Side Of Steering Column

COMPONENT LOCATION VIEWS

8

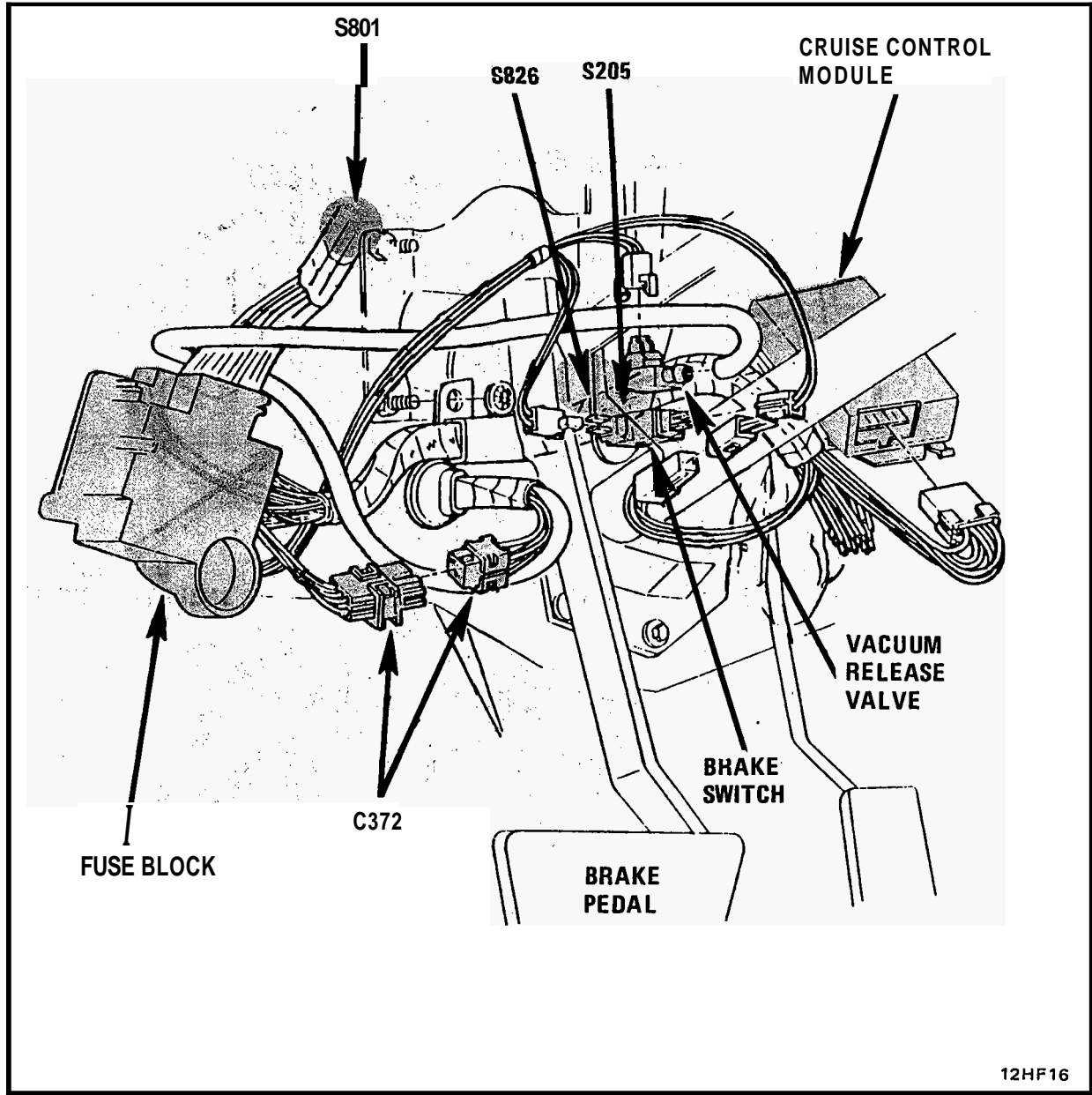

Figure A - Behind LH Side Of I/P

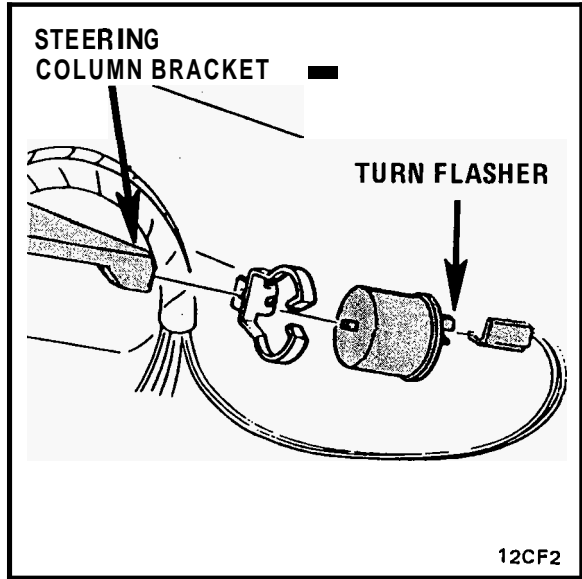

Figure B - RH Side Of Steering Column Bracket

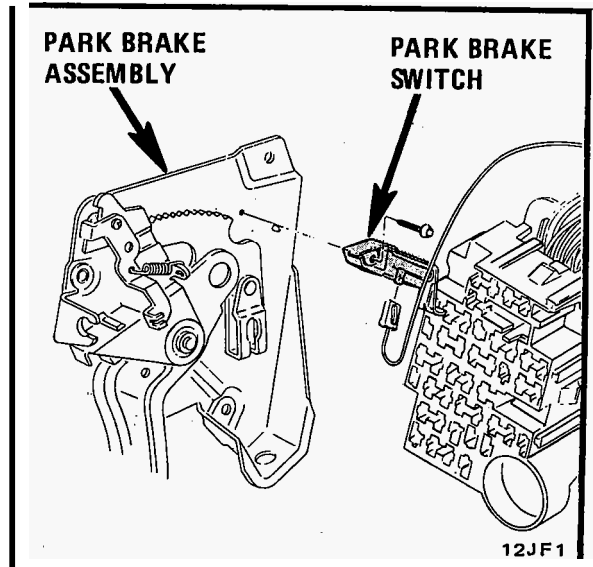

Figure C - Behind LH Side Of I/P

COMPONENT LOCATION VIEWS

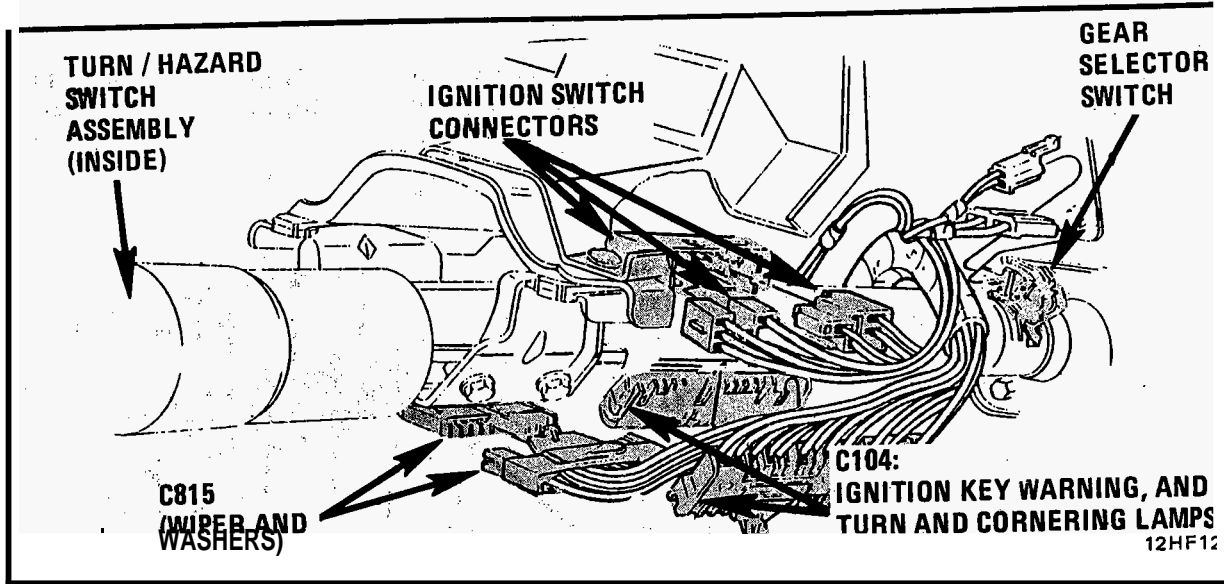

Figure A - RH Side Of Steering Column

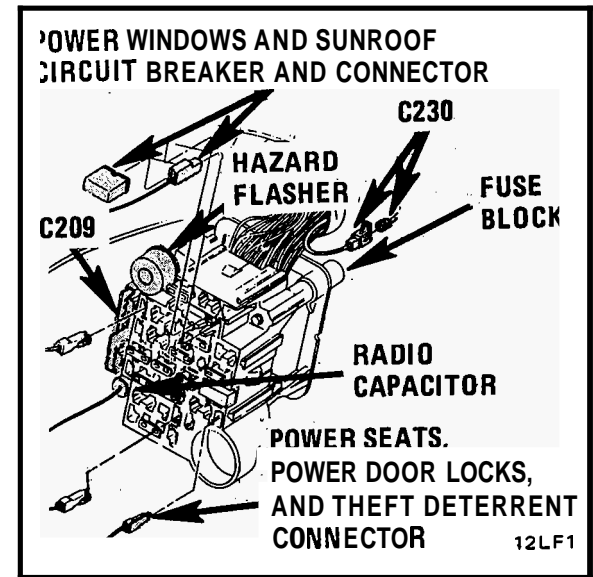

Figure C - Behind LH Side Of I/P

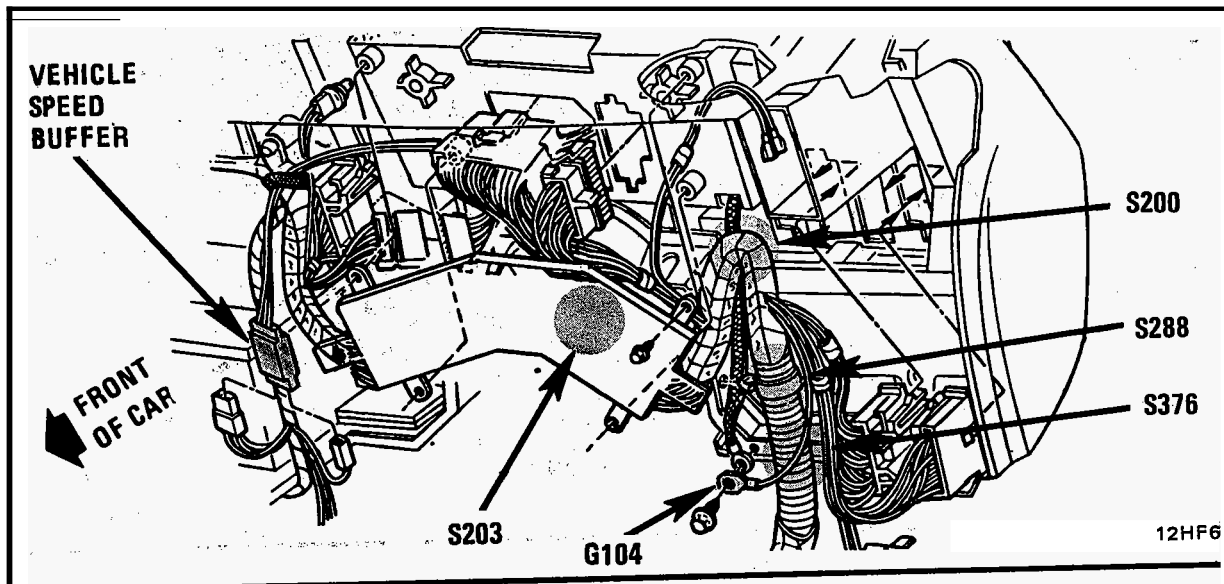

Figure B - Behind LH Side Of I/P

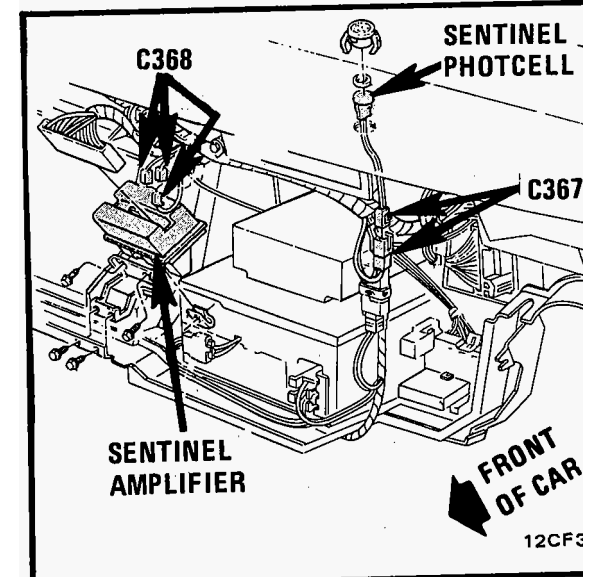
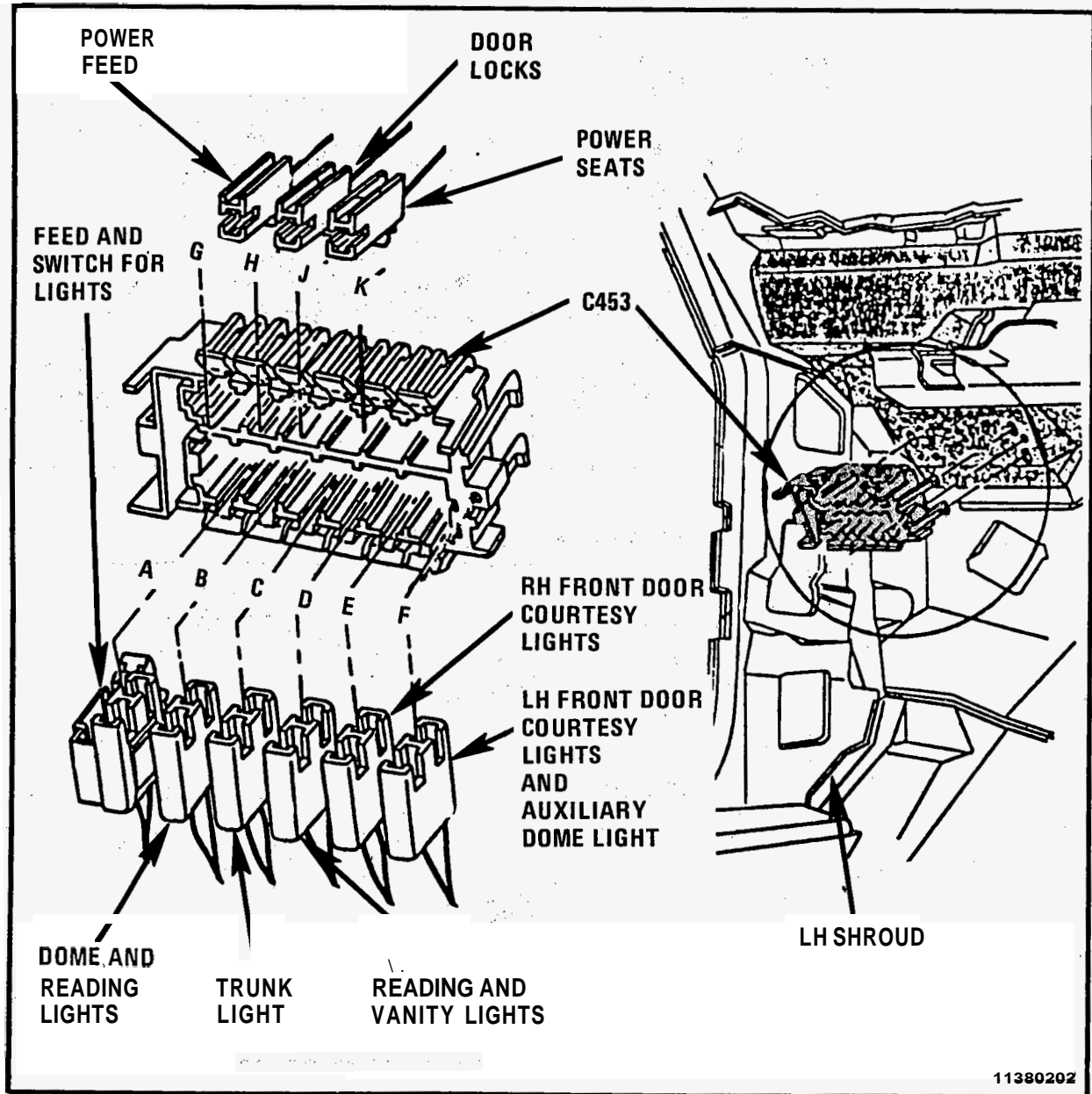

Figure D - Behind Center Of I/P

COMPONENT LOCATION VIEWS

la



11380202

Figure A - Near LH Shroud, C453 Views

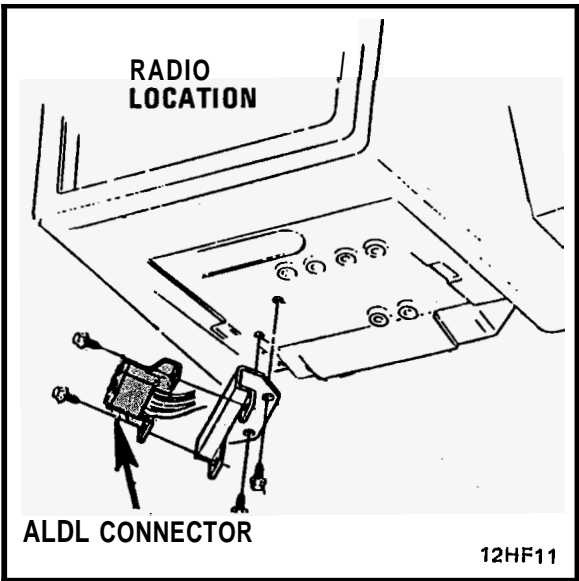

Figure B - Below Center Of I/P

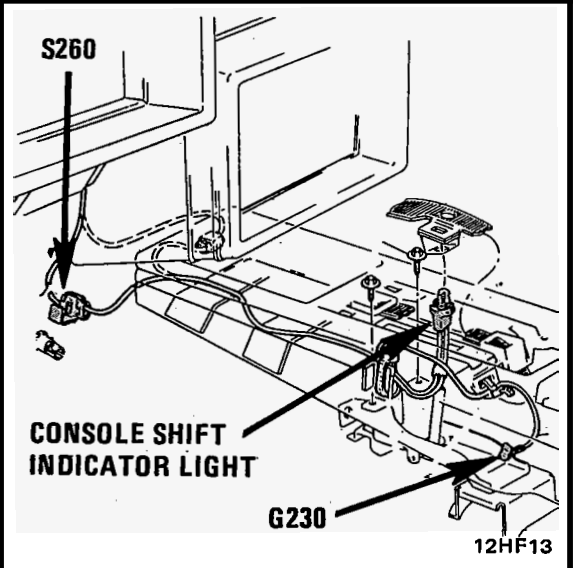

Figure G - Front Of Center Console

COMPONENT LOCATION VIEWS

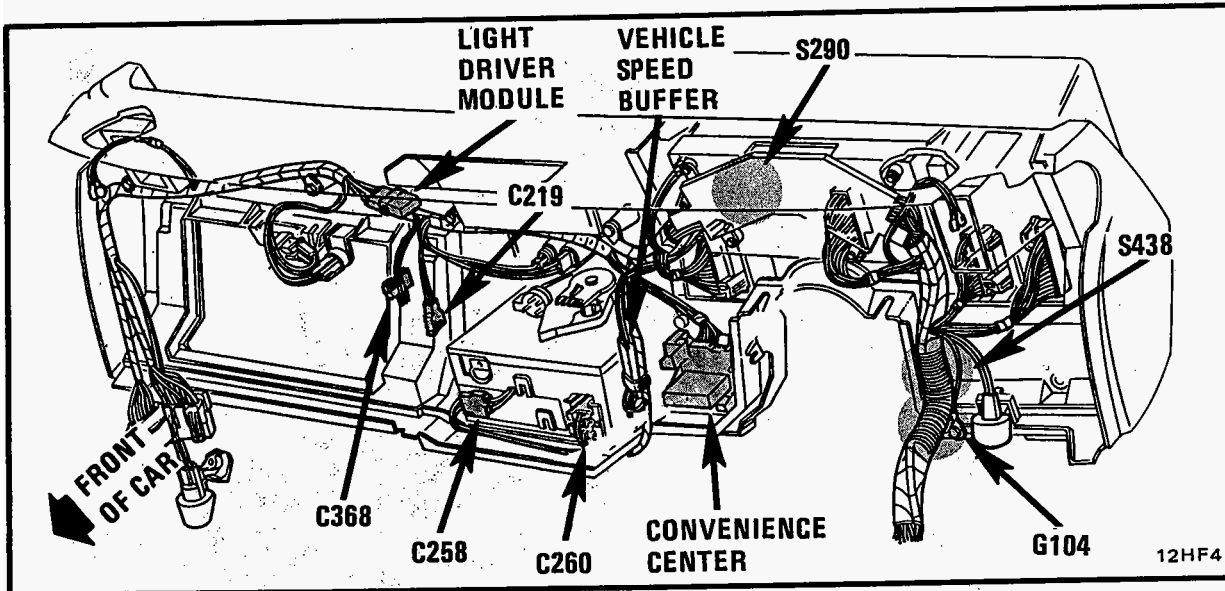

Figure A - Behind I/P

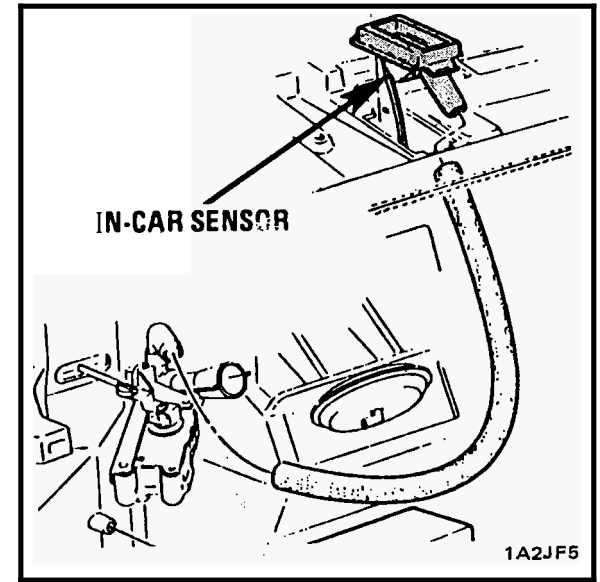

Figure C - Right Center Top Of I/P

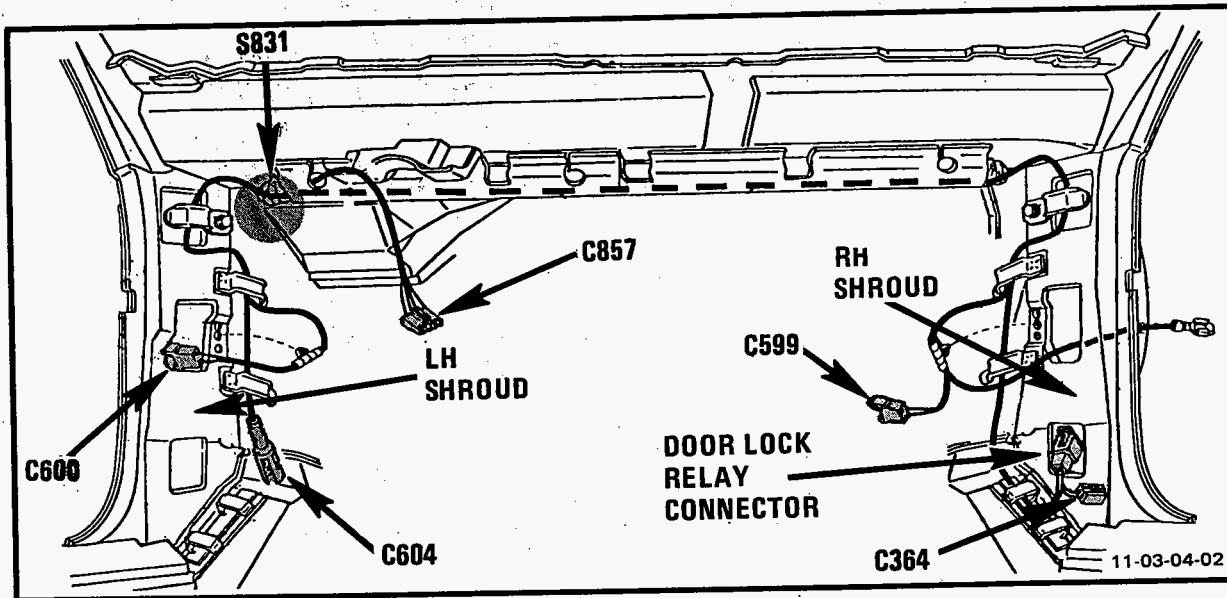

Figure B - Behind I/P, Cross Car Harness

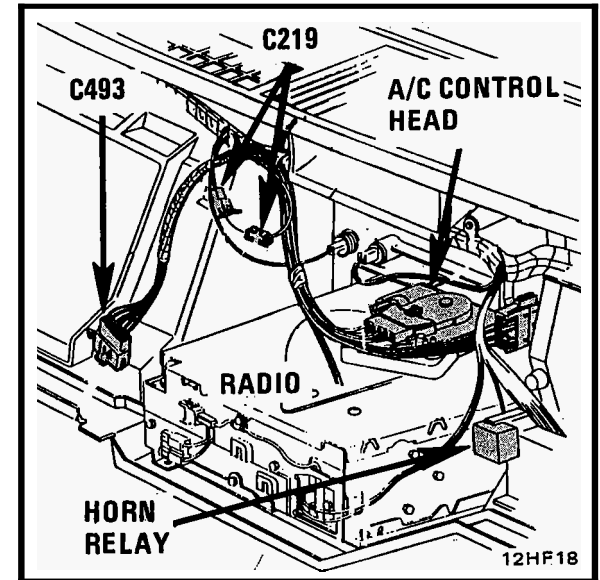

Figure D - Behind Center Of I/P

COMPONENT LOCATION VIEWS

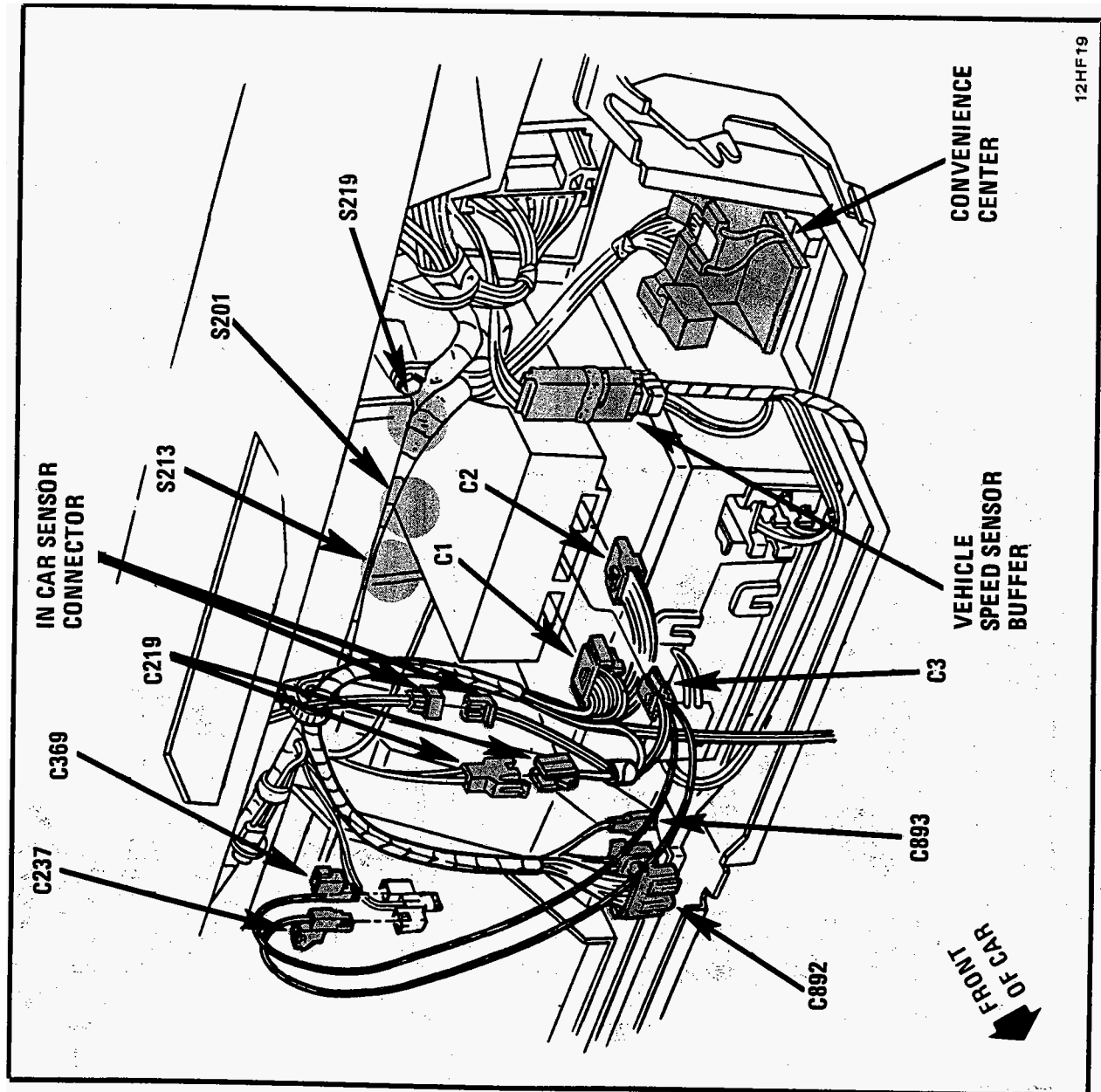

Figure A - Behind Center Of I/P

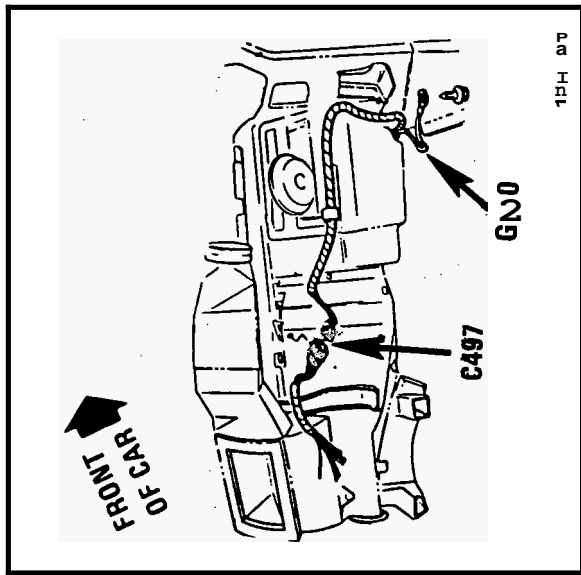

Figure B - Behind RH Side Of I/P

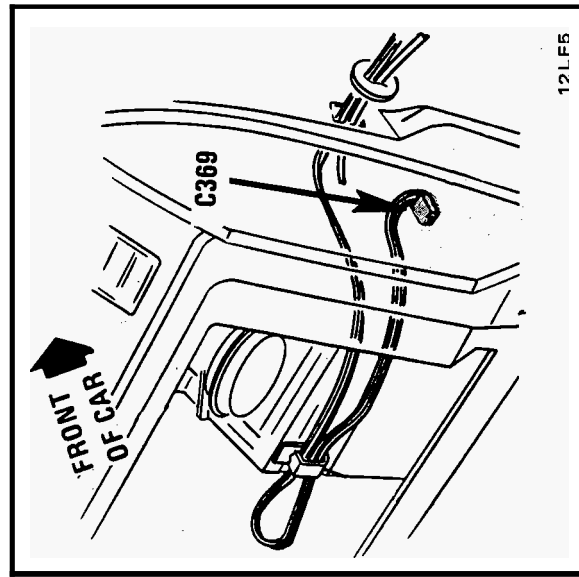

Figure C - Behind I/P, Right Of Radio

COMPONENT LOCATION VIEWS

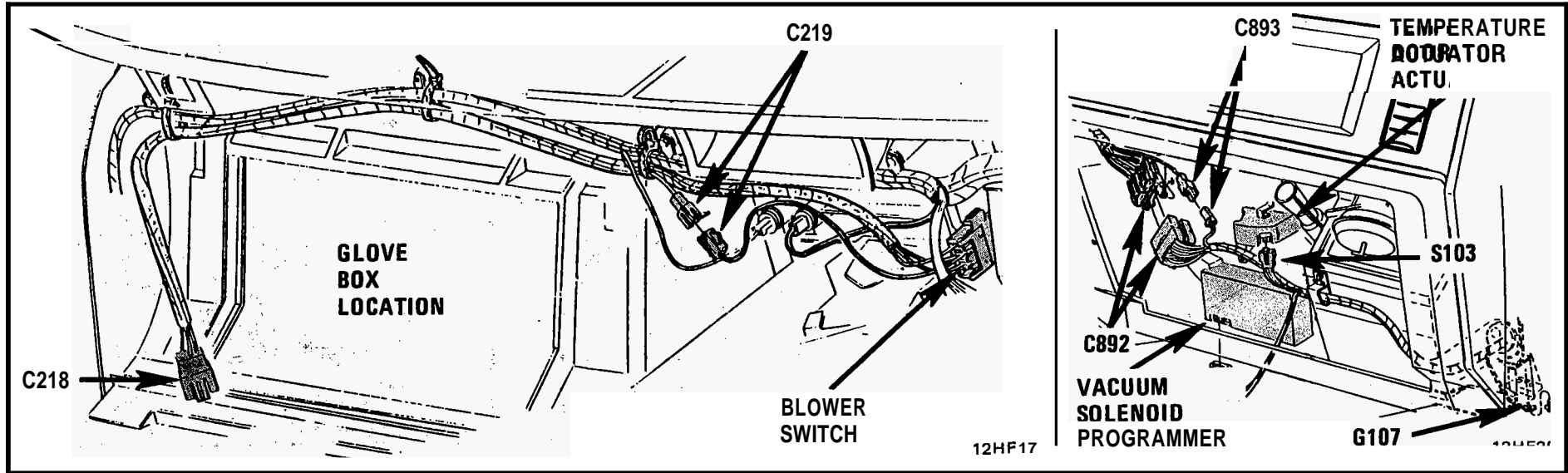

Figure A - Behind RH Side Of I/P

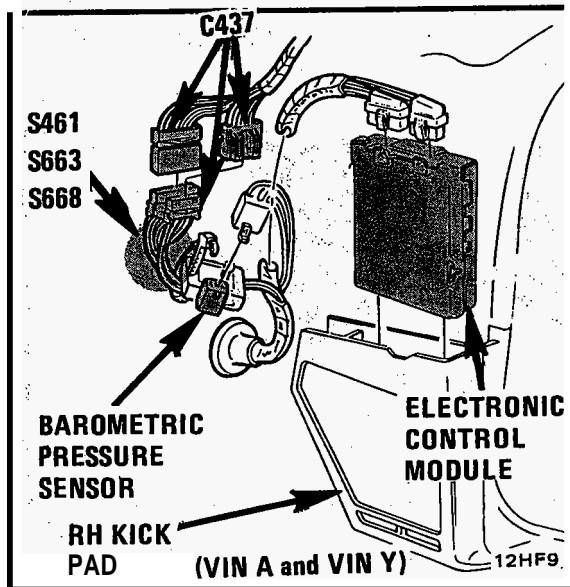

Figure B - Behind RH Side Of I/P

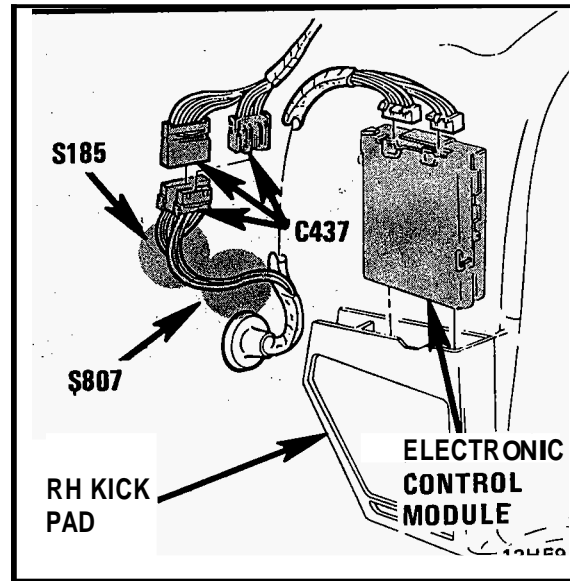

Figure C - Behind RH Side Of VIN 7 I/P

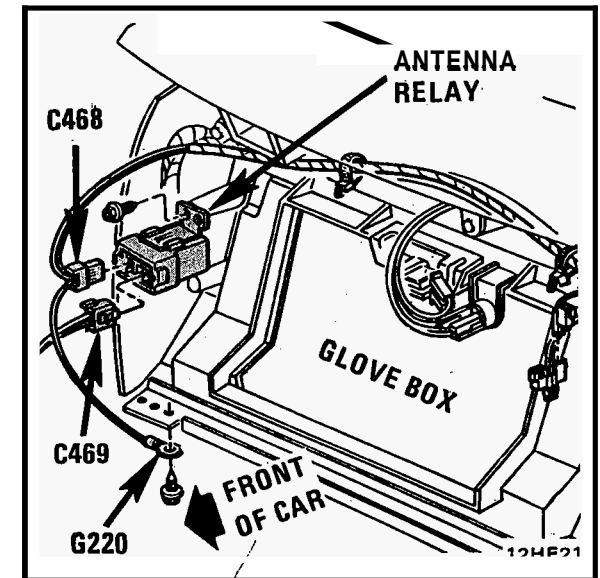

Figure D - Behind RH Side Of I/P

COMPONENT LOCATION VIEWS

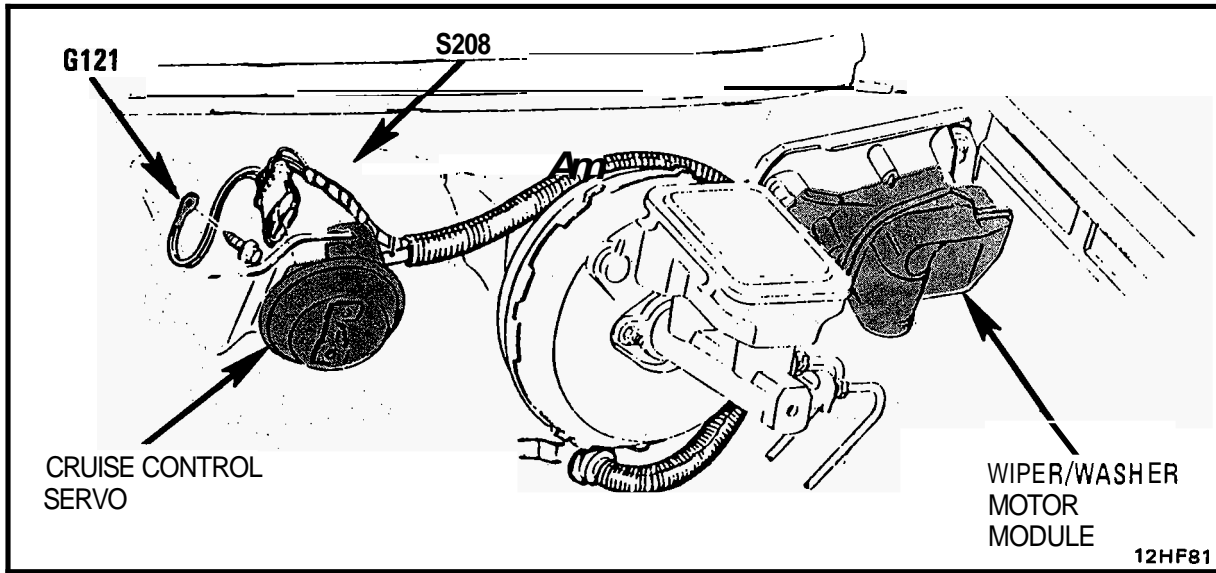

Figure A • LH Front Of Dash (VIN A)

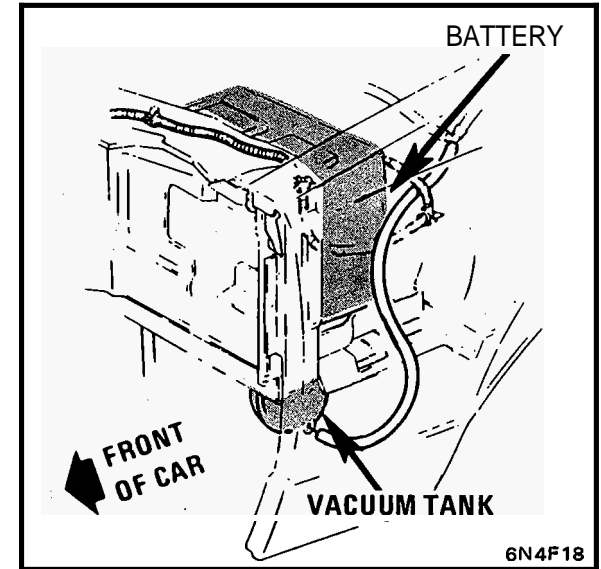

Figure D • Left Front Fender

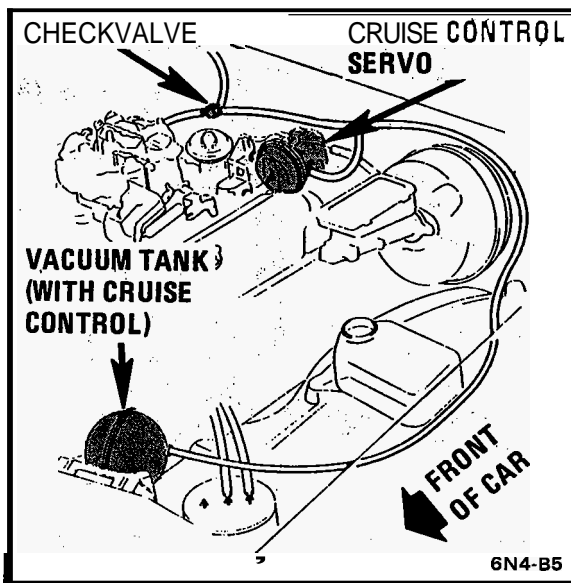

Figure B • LH Side Of VIN A Engine Compartment

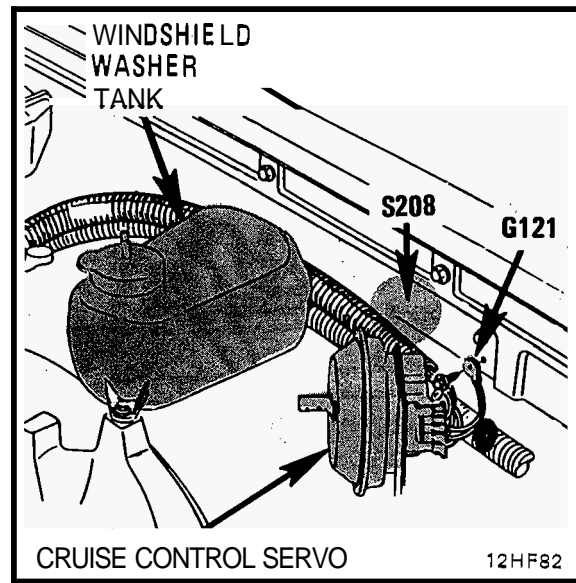

Figure C • Inside LH Front Fender (VIN 7)

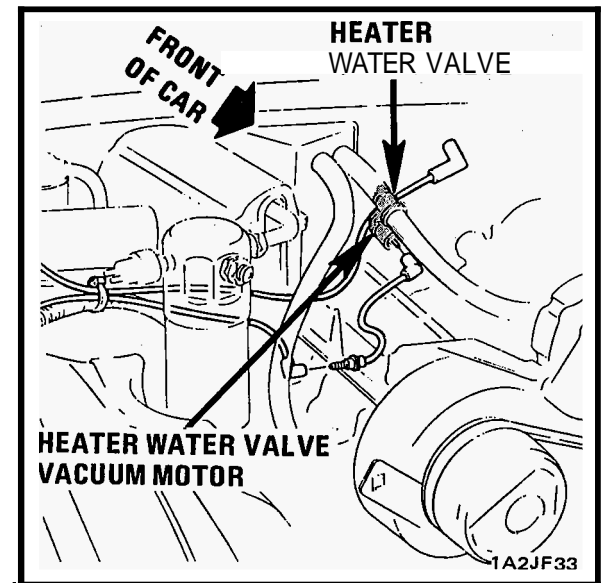

Figure E • RH Rear Of Engine compartment

COMPONENT LOCATION VIEWS

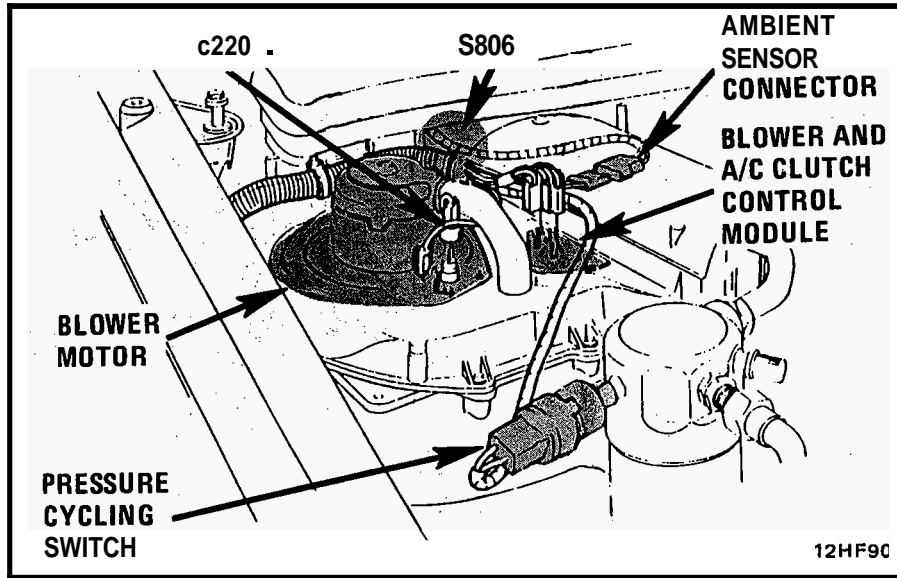

Figure A • RH Front Of Dash VIN 7 Electronic A/C

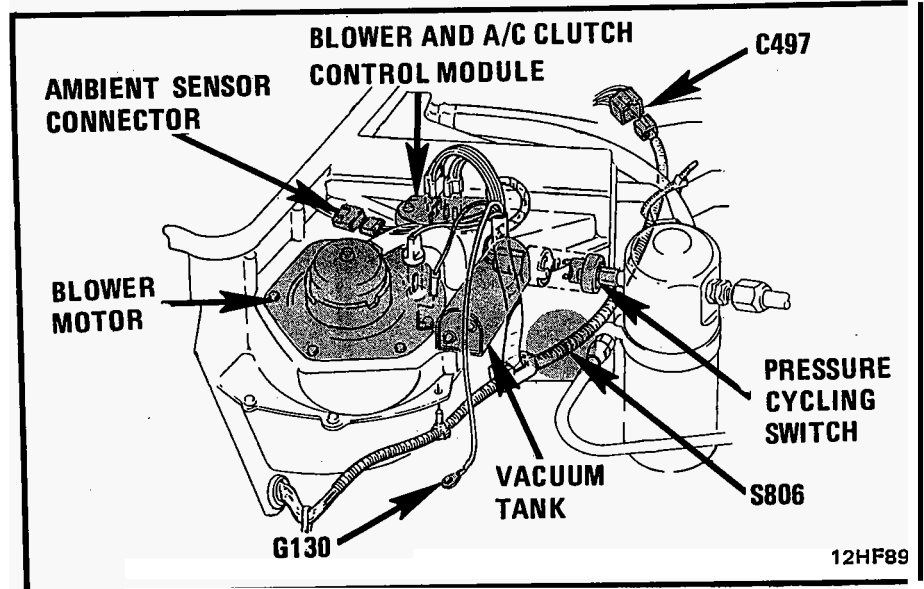

Figure C • RH Rear Of Engine Compartment (VIN A And VIN Y)

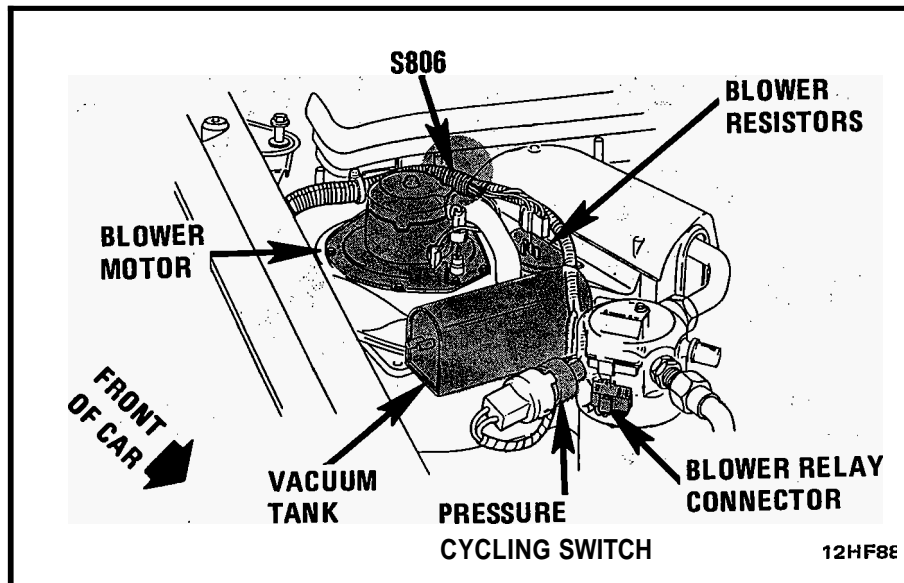

Figure B • RH Rear Of VIN 7 Engine Compartment

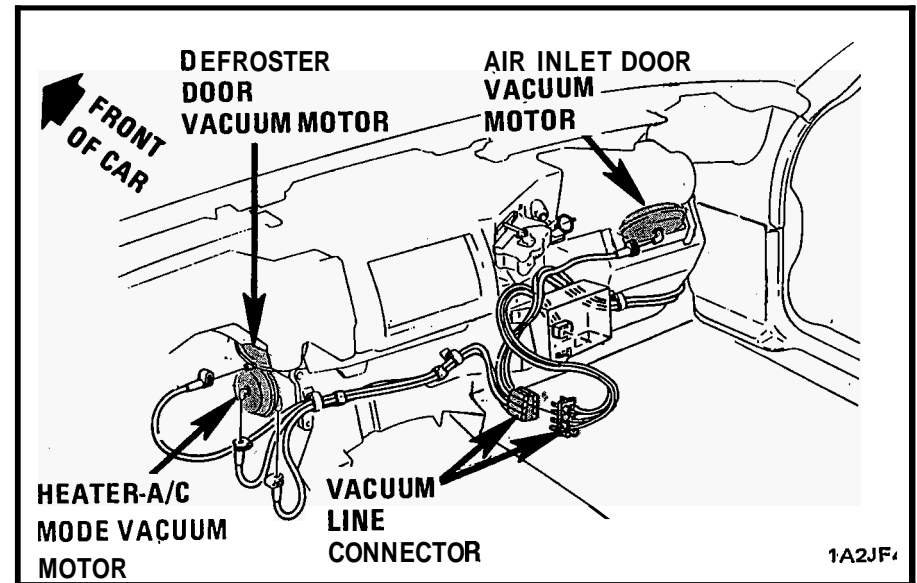

Figure D • Behind I/P (Electronic A/C)

COMPONENT LOCATION VIEWS

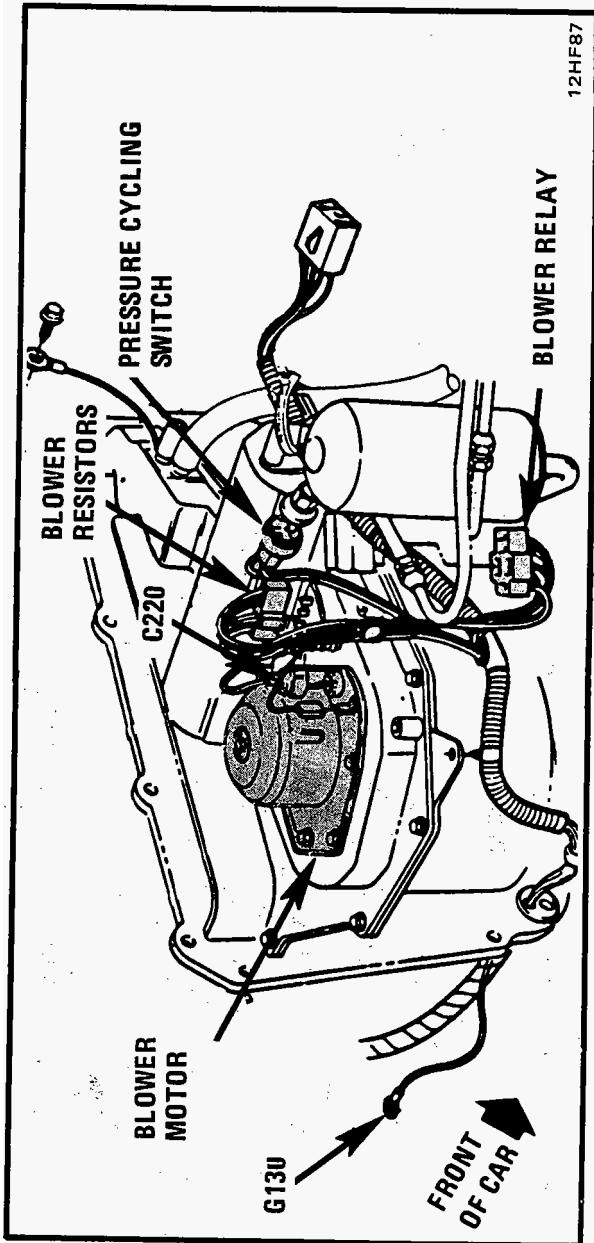

Figure A - RH Rear Of Engine Compartment (VIN A And VIN Y)

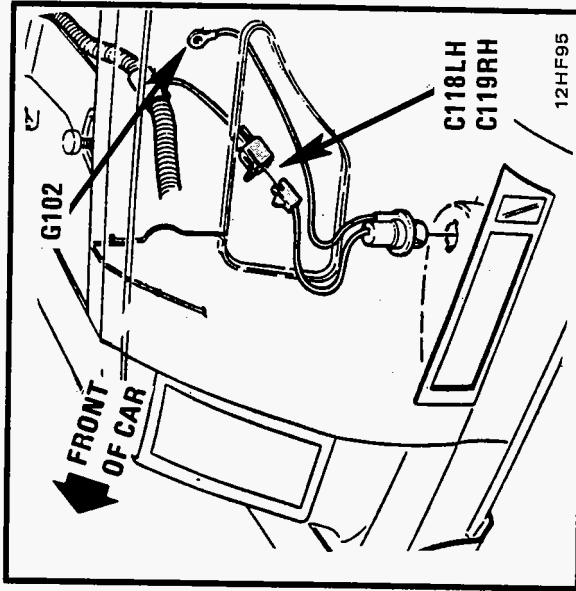

Figure D - LH Front Corner Of Car

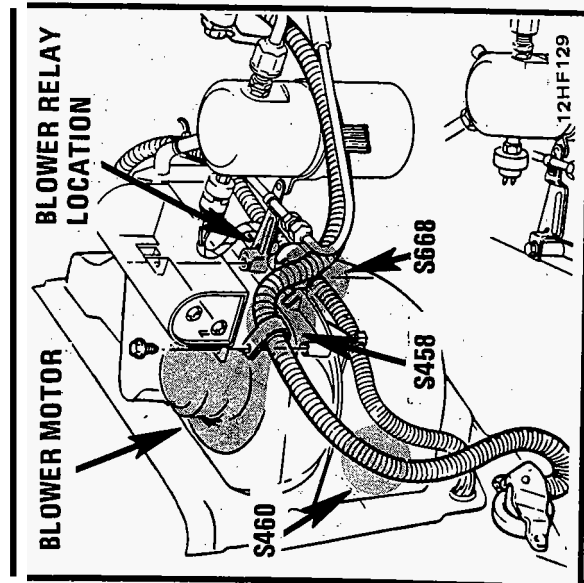

Figure B - RH Rear Corner Of VIN A Engine Compartment

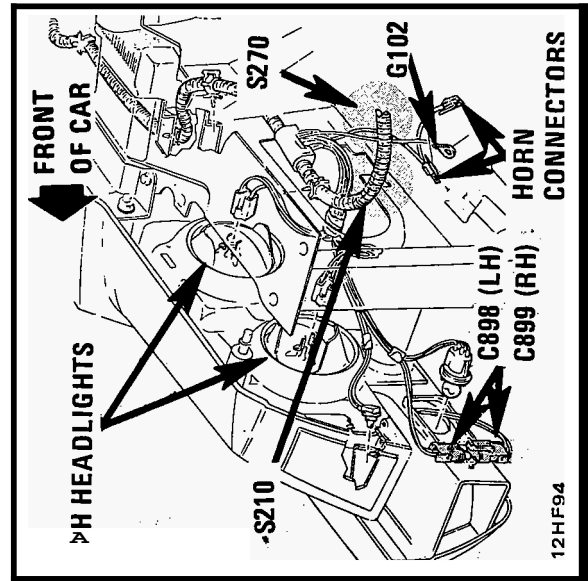

Figure C - Behind LH Headlights

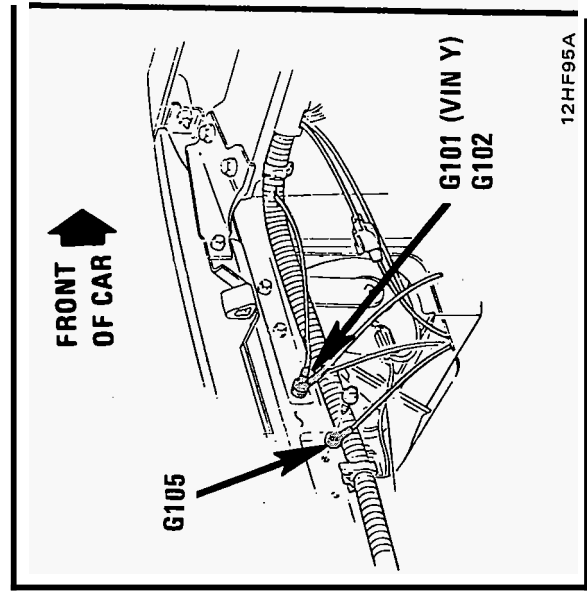

Figure E - LH Front Of Engine Compartment