

**1987  
CHASSIS SERVICE MANUAL**

**Volume II**

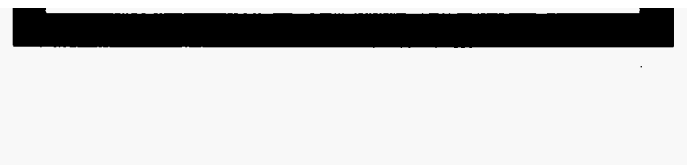

**BUICK**





# 1987 BUICK

## ELECTRICAL DIAGNOSIS MANUAL

### CONTENTS

INTRODUCTION . . . . . 2-0

SYMBOLS . . . . . 3-1

TROUBLESHOOTING PROCEDURES. . . . . 4-0

TROUBLESHOOTING TOOLS. . . . . 4-2

TROUBLESHOOTING TESTS. . . . . 4-3

REPAIR PROCEDURES . . . . . 5-0

ELECTRICAL CIRCUITS

CENTURY ("A" CARLINE). . . . . CONTENTS

LESABRE ESTATE WAGON/ELECTRA ESTATE  
WAGON ("B" CARLINE),. . . . . CONTENTS

ELECTRA/PARK AVENUE  
("C" CARLINE) . . . . . CONTENTS

RIVIERA ("E" CARLINE) . . . . . CONTENTS

REGAL ("G" CARLINE) . . . . . CONTENTS

LESABRE ("H" CARLINE) . . . . . CONTENTS

SKYHAWK ("J" CARLINE) . . . . . CONTENTS

SOMERSET/SKYLARK  
("N" CARLINE) . . . . . CONTENTS

## DIAGNOSTIC INFORMATION

This manual contains the following kinds of diagnostic information:

- Electrical Schematics
- Component Location Lists
- Harness Connector Faces
- Troubleshooting Hints
- System Checks
- System Diagnosis
- Circuit Operation Descriptions
- Harness Routing Views
- Input Test

Using these elements together will make electrical troubleshooting faster and easier. Each element is described below.

The **Electrical Schematic** should always be your starting point in using this Electrical Troubleshooting Manual. The schematic shows the electrical current paths when a circuit is operating properly. It is essential to understand how a circuit should work before trying to figure out why it doesn't.

The **Harness Connector Faces** show the cavity or terminal locations in **all** the multi-pin connectors shown in the schematic. Together with the wire colors and terminals given in the schematic, they help you locate test points. The drawings show the connector faces you see after the harness connector has been disconnected from a component. When more than one connector is connected to a component the connectors are all shown together. Both halves of in-line connectors are shown together.

The **Troubleshooting Hints** offer short-cuts or checks to help you determine the cause of a complaint. They are not intended to be a rigid

procedure for solving an electrical situation. Rather, **Troubleshooting Hints** represent a common-sense approach, based on an understanding of the circuit.

The **System Check** gives a summary of how the circuit should be operated and what should happen. This is especially important when you are working on a new system. The **System Check** will help you identify symptoms, lead you to diagnosis and confirm the system after repair.

The **System Diagnosis** provides a procedure to follow that will locate the condition in a circuit. If your own knowledge of the system and the **Troubleshooting Hints** have not produced a quick fix, follow the **System Diagnosis**. All procedures are based on symptoms to assist you in locating the condition as fast as possible.

The **Circuit Operation**, will help you understand the circuit. It describes the components and how the circuit works.

The **Component Location List** helps you find where the parts of the circuit are in the vehicle. A brief statement of the location is given and also a reference to a drawing that shows the component and its connecting wires. These **Component Location Views** are in section **201**.

**Harness Routing Views** are found in cell **203**. These views show the routing of the major wiring harnesses and the in-line connectors between the major harnesses. These views will make troubleshooting easier when you are not sure about harness routing.

## Riviera ("E" Car) ONLY

The **Input Tests** sections permit you to use the **Body Computer (BCM)** to troubleshoot circuits that interface with the **BCM** and **IPC**. The step-by-step test procedures in **Cells 301 (BCM Input Tests)** and **302 (Instrument Panel Input Tests)** should be used after a circuit problem is isolated by using a **System Diagnosis**. The **System Diagnosis** procedures direct you to the proper **Diagnostic Test** procedure.

## PAGE NUMBER

This section is organized into cells with most cells containing a circuit schematic and the text for that circuit. This makes the section easy to use, since the page number for a schematic will normally stay the same year after year, and it will also be the same in all the GM publications about that circuit. For example, the **Cruise Control** schematic will always be the first pages of cell **34**. The other information for **Cruise Control** follows them and is page **34-2, 34-3**, etc.

Some cells may have more than one circuit schematic, such as power distribution, interior lights, and air conditioning. The circuit you want can either be located by using the index, or by a quick look through the related cell.

All the engine circuits for a particular engine VIN type are in the same cell. This makes that cell easy to use, since schematics for other cars are not in your way. The instrument panel schematics are organized similarly. If you are working on a 'car with a **Digital Cluster**, only the schematics that apply to that car's **Digital Cluster** will be in the cell you use. Information on the **Indicators and Gages Clusters** will be in other cells.

**SCHEMATICS**

These schematics break the entire electrical system down into individual circuits. You are not distracted by wiring which is not part of the circuit you're working on.

It is important to realize that no attempt is made on the schematic to represent components and wiring as they physically appear on the car. For example, a 4-foot length of wire is treated no differently in a schematic from one which is only a few inches long. The number of cavities for each connector is listed in the Component Location List. Similarly, switches and other components are shown as simply as possible, with regard to function only.

The following example shows how to read a Horn schematic, see figure 1. Locate the Horn schematic using the Index. The circuit schematic will look somewhat like the one to the right. The schematic is read from top to bottom.

Voltage is applied to the Horn Relay at all times. When the relay coil is grounded by closing the Horn Switch, the relay contacts close. When the relay contacts are closed, both the LH and RH Horns are energized.

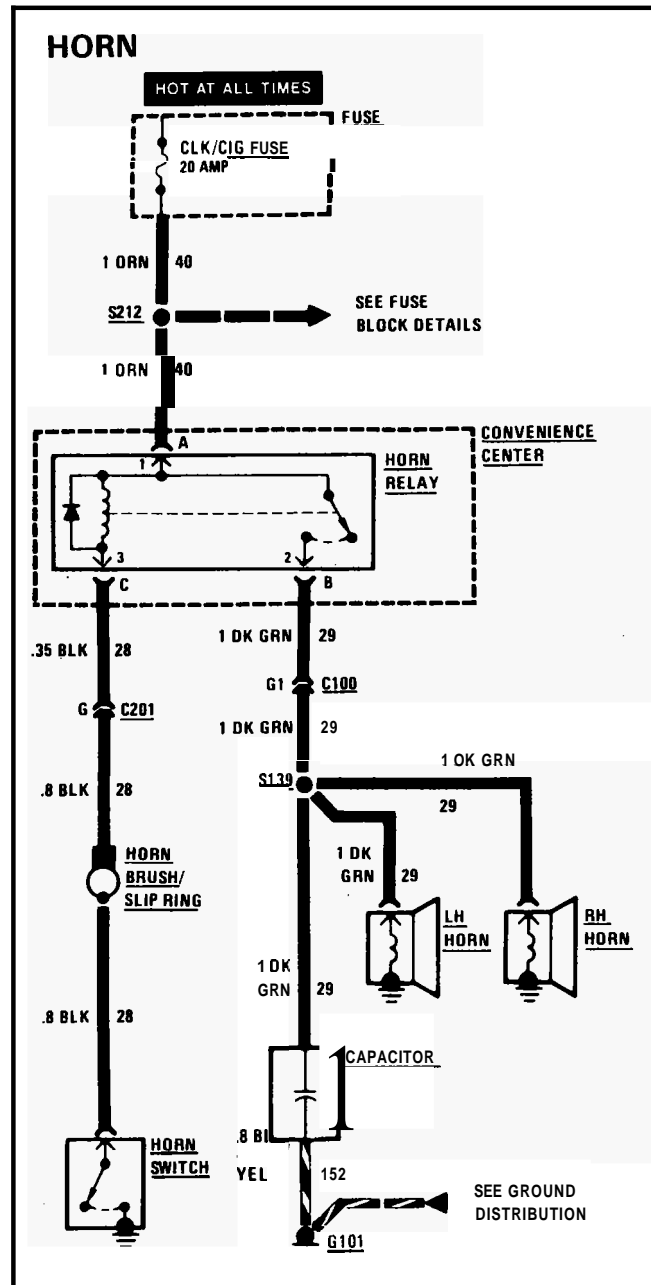

Figure 1 - Typical Horn Schematic

**COMPONENT LOCATIONS**

When you are ready to locate the schematic components on the car, use the Component Locations List, see figure 2.

Listed in the left hand column are the components shown on the schematic. Next to the Convenience Center is the location, "Under LH side of I/P." Reference to LH and RH is made as though the troubleshooter was sitting in the driver's seat. On the same line, in the far right column, is a page-figure reference. In this case, you are directed to figure **A** on page 201-6.

Where connectors are listed, the number of cavities is provided. This represents the total number of cavities in the connector, regardless of how many are actually used. This information is provided to help you identify connectors on the car.

Grounds are listed next in the table. The location description for G 101 reads, "LH front of engine compartment, behind headlights panel." You are directed to page 201-8 figure D.

Nearly every component, connector, ground or splice shown on a schematic can be pinpointed visually by using the Component Location Views figures.

<b>COMPONENT LOCATION</b>		Page-Figure
<b>COMPONENTS</b>		
Convenience Center .....	Under LH side of I/P .....	201-6-A
Fuse Block .....	Under LH side of I/P .....	201-6-A
Horn Brush/Slip Ring .....	Under steering wheel .....	201-5-E
Horn Switch .....	Under steering wheel .....	201-5-E
<b>CONNECTORS</b>		
C100 (46 cavities) .....	LH side of dash .....	201-5-B
C201 (11 cavities) .....	Under LH side of I/P, near C100 .....	201-5-F
<b>GROUNDINGS</b>		
G101 .....	LH front of engine compartment, behind headlights panel. ....	201-8-D
<b>SPLICES</b>		
S139 .....	Front lights harness, behind LH front light panel	201-8-C
S212 .....	I/P harness, behind I/P, above steering column. . .	201-6-B

**Figure 2 - Typical Entries In The Component location List**

**HARNES CONNECTOR FACES**

The connectors, see figure 3, are labeled with the component they are connected to, or the connector number, C224, from the schematic where they appear **and** their color. The identifying number is for reference only; it is not the connector part number. For in-line connectors, the half shown is usually the Socket half. If both views are shown, the other is marked **Pin** Half.

Only connectors that have two or more terminals are shown.

If you **need to** backprobe a connector while it is on the component, the order of the terminals must be mentally reversed. The wire color is a help in **this** situation. If there is more than one wire of the **same** color, you may **need** to locate a test point from its terminal number. **A** useful trick is to imagine that you are probing a terminal from **behind** the page you are looking at. Then mentally locate that terminal with respect to the keyway or other reference mark.

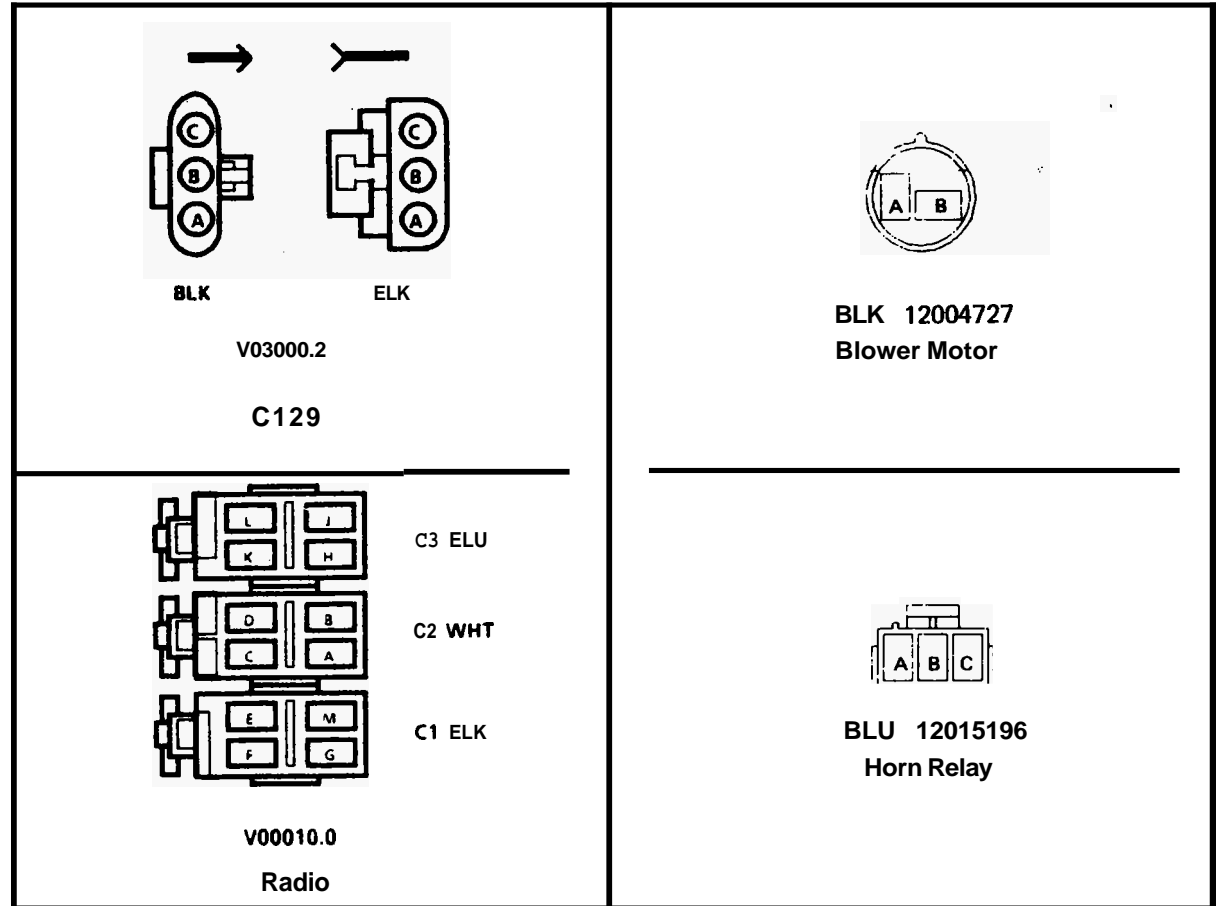

Figure 3 -Typical Harness Connector Faces

## OTHER INFORMATION

### Body Part Names

Refer to figure 4 for the correct body part names.

### VIN References

If schematics for more than one variation of an engine type—V6, for example—are shown, then the schematics will be labeled with VIN designations to distinguish the variations.

### Service Parts Identification Label

To aid service and parts personnel in identifying options and parts originally installed, a Service Parts Identification Label has been placed in the car. See the General Information Section **OA** of the Chassis Service Manual for the location of the label and the definition of the option codes.

### Abbreviations

A/C – Air Conditioning

BCM – Body Computer Module

ECM – Electronic Control Module or Engine Control Module

I/P – Instrument Panel

RH – Right Hand, as seen from driver's seat

LH – Left Hand

Not Used – The connector cavity has no function.

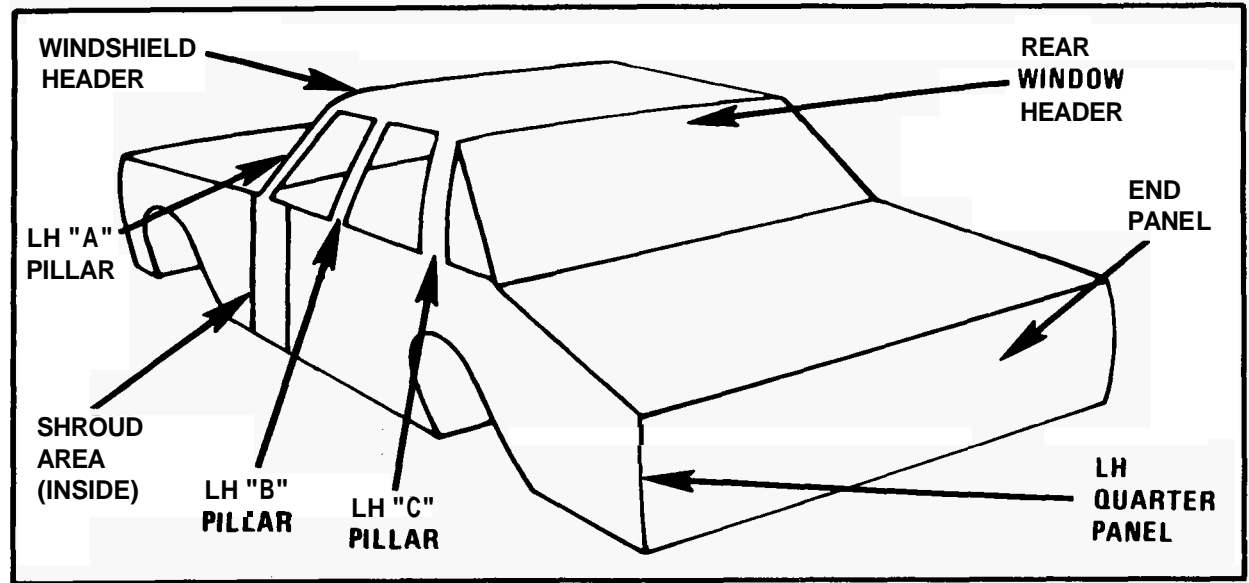

Figure 4 - Body Part Names







# INTRODUCTION

## Light Switch Details

The Light Switch Details schematic, see figure 7, shows the wiring between the Light Switch and the components connected to the

output of the Light Switch. In certain instances where space permits, some of this detail may be shown on the Power Distribution schematic. The Light Switch Details sche-

matic helps you understand the many wires that come from the Light Switch. This schematic is also helpful in locating a short circuit that causes the fuse ahead of the Light Switch to open.

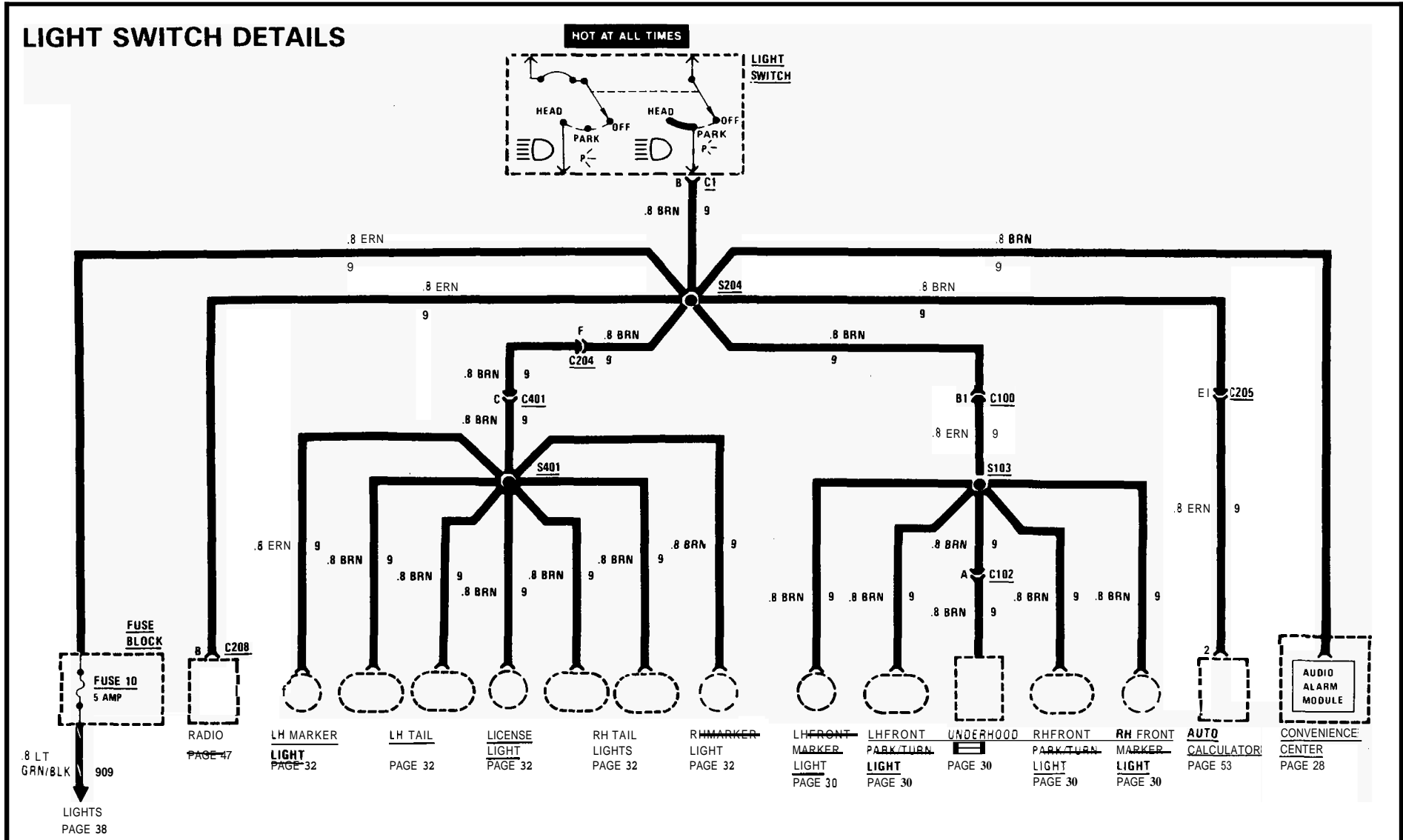

Figure 7 - Typical Light Switch Details Schematic

# INTRODUCTION

## Ground Distribution

Figure 8 is a sample Ground Distribution schematic for the Headlights. It shows exactly which components share each ground. This information can often be a time-saver when troubleshooting ground circuits.

For example, if both Headlights and the Park/Turn Light on one side are all out, you could suspect an open in their common ground wire or the ground connection itself. On the other hand, if one of the lights works, you know that the ground and the wire up to the splice are good. You have learned this just by inspecting the schematic and knowing the vehicle's symptoms. No actual work on the lighting system was needed.

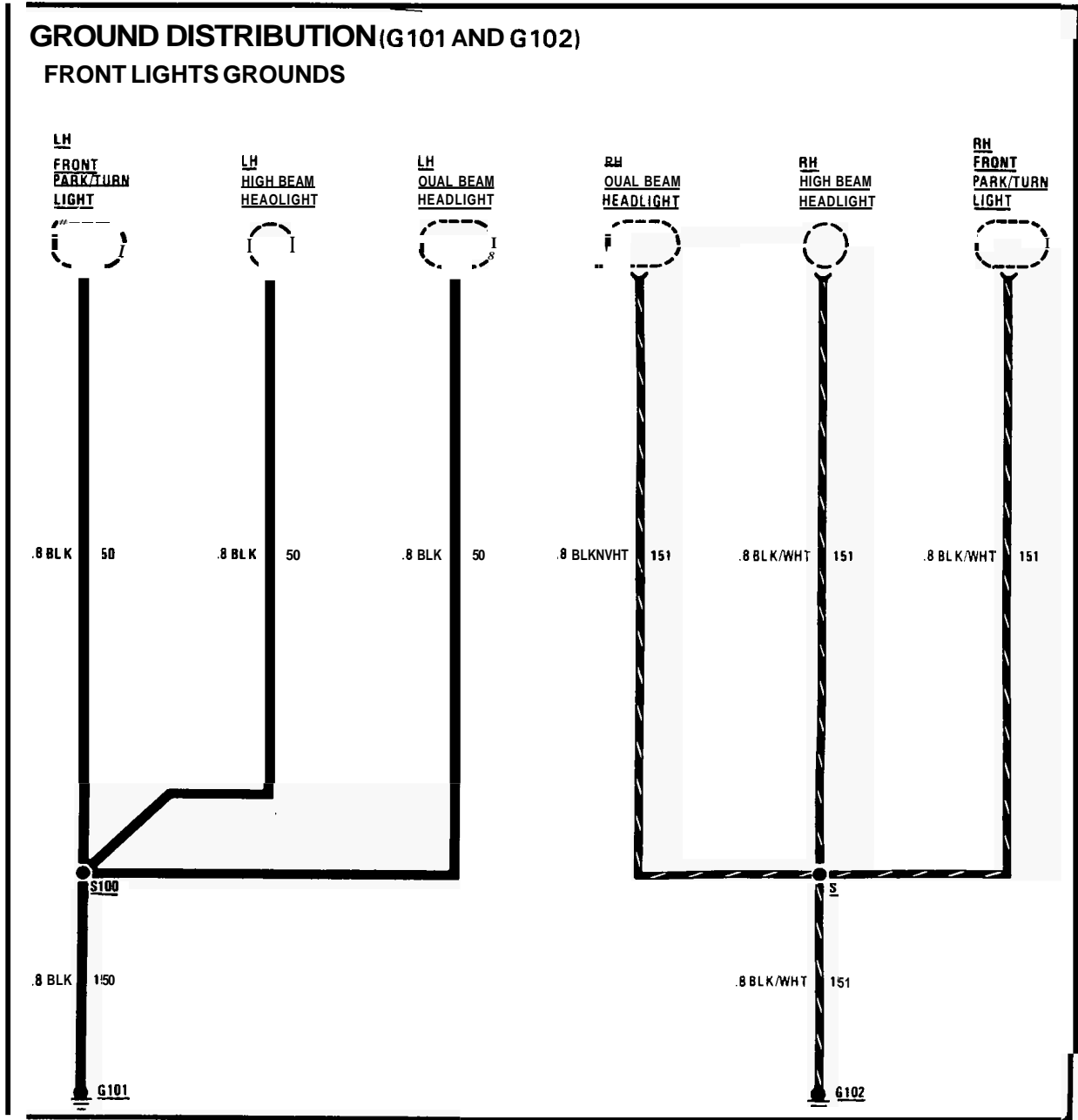

Figure 8 - Typical Ground Distribution Schematic

# SYMBOLS



ENTIRE COMPONENT SHOWN



PART OF A COMPONENT SHOWN

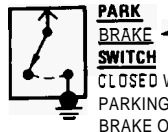

**PARK BRAKE SWITCH**  
NAME OF COMPONENT  
CLOSED WITH PARKING BRAKE ON  
DETAILS ABOUT COMPONENT OR ITS OPERATION



COMPONENT CASE IS DIRECTLY ATTACHED TO METAL PART OF CAR (GROUNDED)

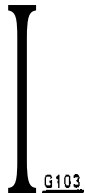

WIRE IS ATTACHED TO METAL PART OF CAR (GROUNDED)

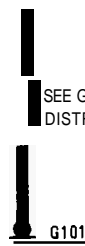

GROUND IS NUMBERED FOR REFERENCE ON COMPONENT LOCATION TABLE

SEE GROUND DISTRIBUTION

WIRE IS INDIRECTLY CONNECTED TO GROUND  
WIRE MAY HAVE ONE OR MORE SPLICES BEFORE IT IS GROUNDED.

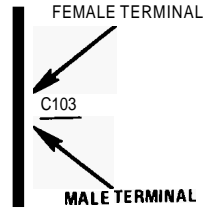

CONNECTOR REFERENCE NUMBER FOR COMPONENT LOCATION TABLE

TABLE ALSO SHOWS TOTAL NUMBER OF TERMINAL POSSIBLE: C103 ( 6 CAVITIES)

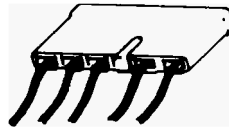

**5 CAVITY** CONNECTOR (5 OUT OF 5 CAVITIES ARE USED)

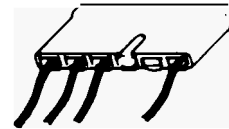

**5 CAVITY** CONNECTOR (4 OUT OF 5 CAVITIES ARE USED)



CONNECTOR ATTACHED TO COMPONENT



CONNECTOR ON COMPONENT LEAD (PIGTAIL)

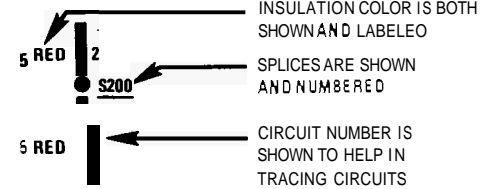

INSULATION COLOR IS BOTH SHOWN AND LABELLED  
SPLICES ARE SHOWN AND NUMBERED

CIRCUIT NUMBER IS SHOWN TO HELP IN TRACING CIRCUITS

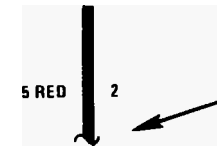

A WAVY LINE MEANS A WIRE IS TO BE CONTINUED

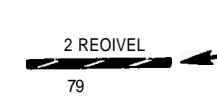

WIRE INSULATION IS ONE COLOR WITH ANOTHER COLOR STRIPE (RED WITH YELLOW)

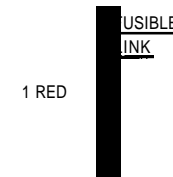

WIRE SIZE AND INSULATION COLOR ARE LABELLED

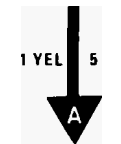

CURRENT PATH IS CONTINUED AS LABELLED. THE ARROW SHOWS THE DIRECTION OF CURRENT FLOW AND IS REPEATED WHERE CURRENT PATH CONTINUES.

TO GENERATOR PAGE 30-0



A WIRE WHICH CONNECTS TO ANOTHER CIRCUIT. THE WIRE IS SHOWN AGAIN ON THAT CIRCUIT.

LIGHTS: TURN/HAZARD/STOP/

# SYMBOLS



CIRCUIT BREAKER

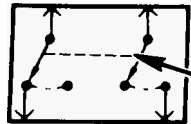

WITCH CONTACTS THAT MOVE TOGETHER

OASHEO LINE SHOWS A MECHANICAL CONNECTION BETWEEN WITCH CONTACTS



TWO TERMINALS IN THE SAME CONNECTORS

OASHEO LINE SHOWS A PHYSICAL CONNECTION BETWEEN PARTS (SAME CONNECTOR)

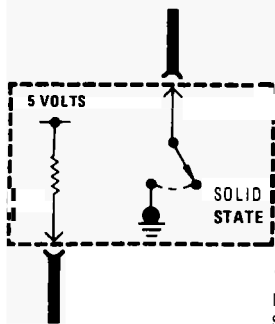

ELECTRONIC CONTROL MODULE (ECM) SOLID STATE

"SOLID STATE" IDENTIFIES MODULE AS ELECTRONIC. SIMPLIFIED COMPONENTS WITHIN THE MODULE SHOW HOW EACH CIRCUIT IS COMPLETED. DO NOT MEASURE RESISTANCE OF CIRCUITS INSIDE SOLID STATE MODULES.

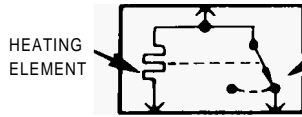

HEATING ELEMENT

HEAT-ACTUATED CONTACT

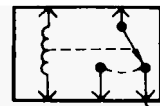

RELAY SHOWN WITH NO CURRENT FLOWING THROUGH COIL

WHEN CURRENT FLOWS THROUGH COIL, CONTACT MOVES FROM NORMALLY OPEN POSITION.

NORMALLY CLOSED CONTACT

NORMALLY OPEN CONTACT

FUSIBLE LINK

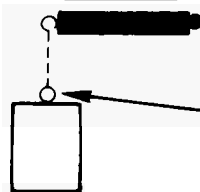

FUSIBLE LINK CONNECTS TO SCREW TERMINAL, SHOWN SEPARATED

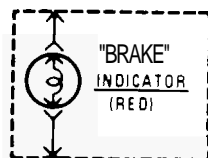

"BRAKE" INDICATOR (RED) AN INDICATOR WHICH DISPLAYS THE LIGHTED WORD "BRAKE"

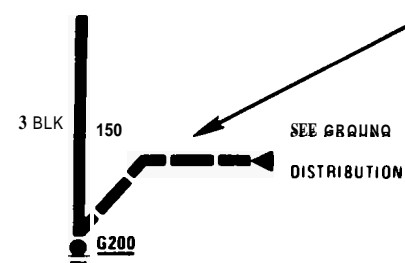

INDICATES THAT THE CIRCUITRY IS NOT SHOWN IN COMPLETE DETAIL BUT IS COMPLETE ON THE INDICATED PAGE

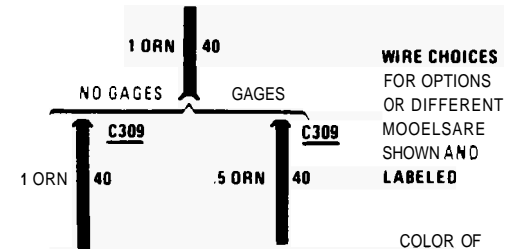

WIRE CHOICES FOR OPTIONS OR DIFFERENT MOELSARE SHOWN AND LABELED

COLOR OF FUSE BLOCK CONNECTOR

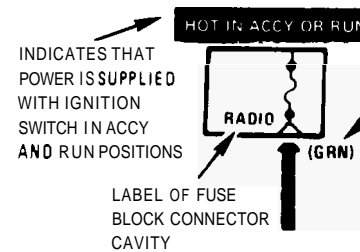

INDICATES THAT POWER IS SUPPLIED WITH IGNITION SWITCH IN ACCY AND RUN POSITIONS

LABEL OF FUSE BLOCK CONNECTOR CAVITY



DIODE CURRENT CAN FLOW ONLY IN THE DIRECTION OF THE ARROW

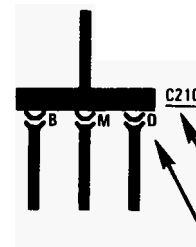

3 CONNECTORS ARE SHOWN CONNECTED TOGETHER AT A JUNCTION BLOCK. FOURTH WIRE IS SOLDER TO COMMON CONNECTION ON BLOCK

NUMBER FOR TOTAL CONNECTOR

LETTERS FOR EACH CONNECTOR

# SYMBOLS

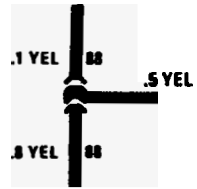

3 WIRES ARE SHOWN CONNECTED TOGETHER WITH A PIGGYBACK CONNECTOR

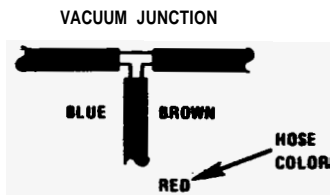

VACUUM JUNCTION

HOSE COLOR

VACUUM SOURCE

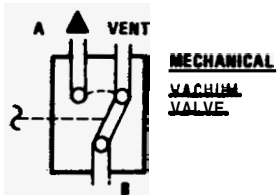

MECHANICAL VACUUM VALVE

IN THE "AT REST" POSITION SHOWN, THE VALVE CLOSURES THE FOLLOWING: PORT A IS SEALED AND PORT B IS VENTED TO THE ATMOSPHERE

VACUUM SOURCE

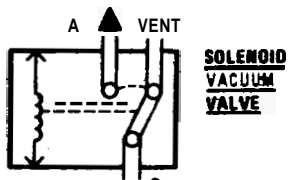

SOLENOID VACUUM VALVE

WHEN THE VALVE IS MOVED TO THE "OPERATED" POSITION, VACUUM FROM PORT A IS CONNECTED TO PORT B

THE SOLENOID VACUUM VALVE USES THE SOLENOID TO MOVE THE VALVE

SINGLE DIAPHRAGM MOTOR

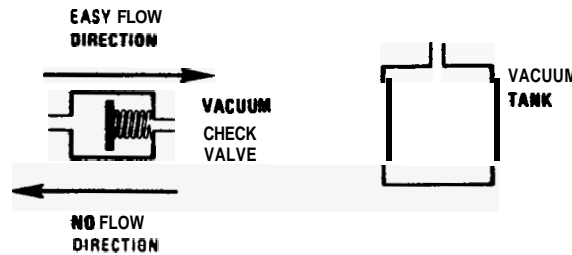
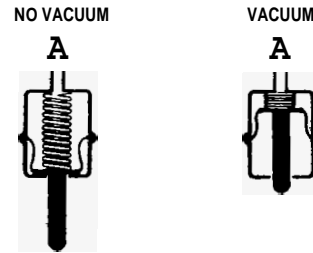

DOUBLE DIAPHRAGM MOTOR

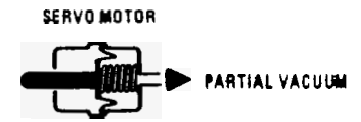
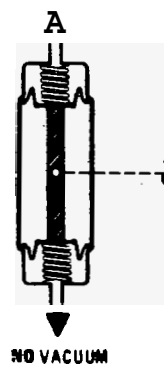

Some vacuum motors such as the servo motor in the Cruise Control can position the actuating arm at any position between fully extended and fully retracted. The servo is operated by a control valve that applies varying amounts of vacuum to the motor. The higher the vacuum level, the greater the retraction of the motor arm. Servo motors work like the two position motors: the only difference is in the way the vacuum is applied. Servomotors are generally larger and provide a calibrated control.

Vacuum motors operate like electrical solenoids, mechanically pushing or pulling a shaft between two fixed positions. When vacuum is applied, the shaft is pulled in. When no vacuum is applied, the shaft is pushed all the way out by a spring.

Double diaphragm motors can be operated by vacuum in two directions. When there is no vacuum, the motor is in the center "at rest" position.

The following four-step troubleshooting procedure is recommended:

### Step 1: Check the problem.

Perform a System Check to be sure you understand what's wrong. Don't waste time fixing part of the problem! Do not begin disassembly or testing until you have narrowed down the possible causes.

The self-diagnostic system built into the Riviera ("E" car) will direct you through sections 8A and 8D of this manual. The service diagnostics are entered by simultaneously depressing OFF and WARMER on the A/C controls for more than two (2) seconds. A diagnostic log will be displayed for the Engine Control Module (ECM) and then for the Body Computer Module (BCM). The display will show only the ECM and BCM codes for circuit problems that are current or history.

If a current ECM code is displayed on the "E" car, Section 8D1 will direct you to the proper diagnostic procedures. If a current BCM code is displayed, Section 8D2 will direct you to the proper diagnostic procedures. If no codes or if history codes are displayed, refer to the problem circuit in this section 8A for diagnostic procedures.

### Step 2: Read the Electrical Schematic.

Study the schematic. Read the Circuit Operation text if you do not understand how the circuit should work. Check circuits that share wiring with the problem circuit. The names of circuits that share the same fuse, ground, switch, etc., are included on each electrical schematic. (Shared circuits are also shown on Power Distribution, Ground Distribution,

Fuse Block Details, and Light Switch pages.) Try to operate the shared circuits. If the shared circuits work, then the shared wiring is OK. The cause must be within the wiring used only by the problem circuit. If several circuits fail at the same time, chances are the power (fuse) or ground circuit is faulty.

### Step 3: Find the Cause and Repair.

- Narrow down the possible causes.
- Use the Troubleshooting Hints.
- Make the necessary measurements as given in the System Diagnosis.

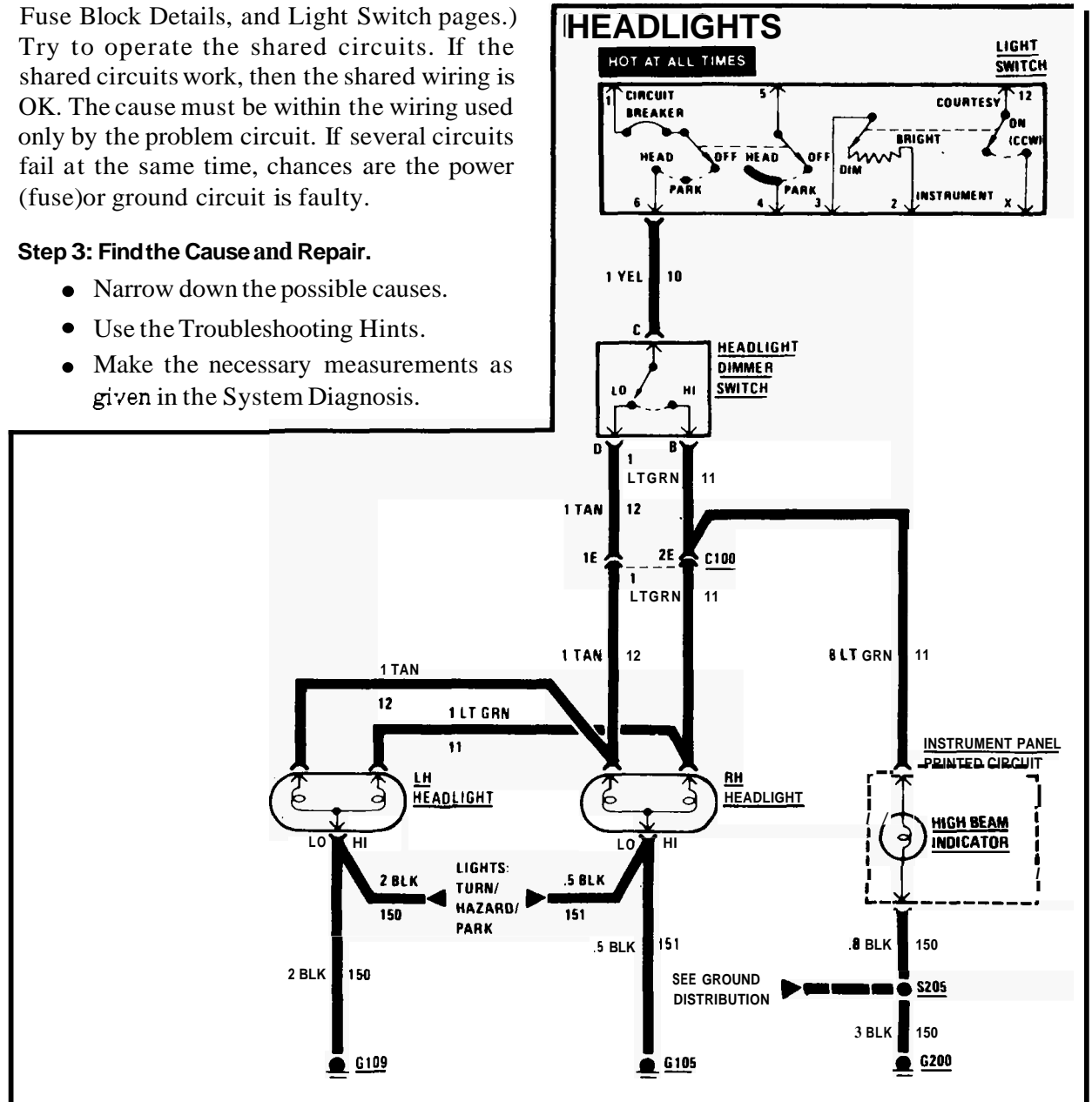

Figure 9 - Typical Headlights Schematic



## TROUBLESHOOTING PROCEDURES

- Before **you** replace a component, check power, signal, and ground wires at the component harness connector. If these check OK, the component must be bad.

### Step 4: Test the Repair

Repeat the System Check to be sure you have fixed the whole problem.

### Example

A customer brings in a car and says that the high beams do not work.

**Step 1:** Perform a System Check on the Headlights Circuit. You may discover that both low beams operate. In "Hi," you may notice that the High Beam Indicator comes on, but neither high-beam operates.

**Step 2:** Read the Headlights electrical schematic, see figure 9. This is the step that will save you time and labor. Remember, it is essential to understand how a circuit *should* work, before trying to figure out why it doesn't.

After you understand how the circuit should operate, read the schematic again, this time keeping in mind what you have learned by operating the circuit.

Since both low beams work, you know that the Light Switch, the YEL wire, the Lo contacts of the Headlight Dimmer Switch, terminal 1E of C100, the TAN wires, and grounds G 105 and G 109 are all good.

Furthermore, since you saw that the High Beam Indicator came on when the Headlight Dimmer Switch was moved to Hi, you know that the Hi contacts of the dimmer switch and the LT GRN wire between the dimmer switch and C100 are good.

At this point, you could test for voltage at the RH Headlight with the dimmer switch in Hi. However, it is extremely unlikely that the high beam filaments have burned out in *both* headlights, or that *both* headlight connections are bad. The cause must be a bad connection at C100, or a break in the LT GRN wire between C100 and the RH Headlight.

You have quickly narrowed the possible causes down to one specific area, and have done absolutely *no* work on the car itself.

**Step 3:** Find the cause and repair it. Using the Component Location List and the corresponding figure, you can quickly find C100 and the LT GRN wire, locate the exact trouble point, and make the repair.

**Step 4:** Check the repair by performing a system check on the Headlights circuit. This, of course, means making sure that both high beams, both low beams, and the High Beam Indicator are all working.

Now suppose that the symptoms were different. You may have operated the Headlights and found that the low beams were working, but neither the high beams nor the High Beam Indicator were working. Looking at the schematic, you might conclude the following:

It is unlikely that both high beam filaments and the High Beam Indicator have all burned out at once. The cause is probably the dimmer switch or its connector.

Electrical troubleshooting requires the use of common electrical test equipment.

## TEST LIGHT/VOLTMETER

Use a test light to check for voltage. A Test Light (BT-7905 or equivalent) is made up of a 12-Volt light bulb with a pair of leads attached. After grounding one lead, touch the other lead to various points along the circuit where voltage should be present. When the bulb goes on, there is voltage at the point being tested.

A voltmeter can be used instead of a test light. While a test light shows whether or not voltage is present, a voltmeter indicates how much voltage is present.

An increasing number of circuits include solid state control modules. One example is the Electronic Control Module (ECM) used with Computer Command Control and Electronic Fuel Injection. Voltages in these circuits should be tested only with a 10-megohm or higher impedance digital voltmeter or multimeter (5-29125 or equivalent). Never use a test light on circuits that contain Solid State components, since damage to these components may result.

When testing for voltage or continuity at a connection, you do not have to separate the two halves of the connector. Unless you are testing a "weather-pack" connector, you should probe the connector from the back. Always check both sides of the connector. An accumulation of dirt and corrosion between contact surfaces is sometimes a cause of electrical problems.

## CONNECTOR TEST ADAPTERS

A connector Adapter Kit is available (535616) for making tests and measurements at separated connectors. This kit contains an assortment of probes which mate with many of the types of connectors you will see. Avoid using paper clips and other substitutes since they can damage terminals and cause incorrect measurements.

## SELF-POWERED TEST LIGHT

Use a self-powered test light (5-21008 or equivalent) to check for continuity. This tool is made up of a light bulb, battery, and two leads. If the leads are touched together, the bulb will go on.

A self-powered test light is used only on an unpowered circuit. First disconnect the car's Battery, or remove the fuse which feeds the circuit you're working on. Select two specific points along the circuit through which there should be continuity. Connect one lead of the self-powered test light to each point. If there is continuity, the test light's circuit will be completed and the bulb will go on.

Never use a self-powered test light on circuits that contain solid state components, since damage to these components may result.

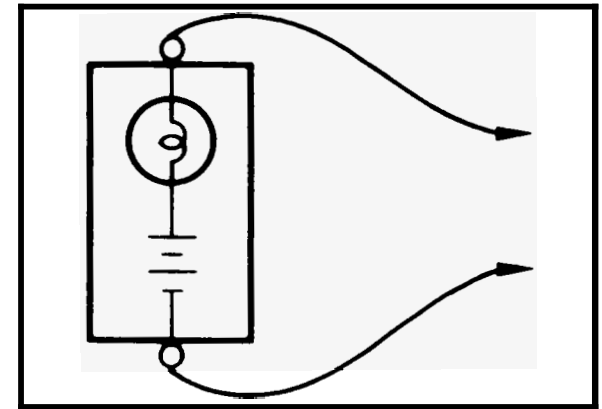

Self-Powered Test Light

## OHMMETER

An ohmmeter can be used instead of a self-powered test light. The ohmmeter shows how much resistance there is between two points along a circuit. Low resistance means good continuity.

Circuits which include any solid state control modules, such as the Electronic Control Module (ECM), should be tested only with a 10-megohm or higher impedance digital multimeter (5-29125 or equivalent).

When measuring resistance with a digital multimeter, the vehicle Battery should be disconnected. This will prevent incorrect readings. Digital meters apply such a small voltage to measure resistance that the presence of voltages can upset a resistance reading.

Diodes and solid state components in a circuit can cause an ohmmeter to give a false reading. To find out if a component is affecting a measurement, take a reading once, reverse the leads and take a second reading. If the readings differ, the solid state component is affecting the measurement.

## TROUBLESHOOTING TOOLS • TROUBLESHOOTING TESTS

### FUSED JUMPER WIRE

A fused jumper is available (5-36169 or equivalent) with small clamp connectors providing adaptation to most connectors without damage. This fused jumper wire is supplied with a **20 amp** fuse which may not be suitable for some circuits. Do not use a fuse with a higher rating than the fuse that protects the circuit being tested.

**CAUTION:** Do not use fused jumper wire in any instance to substitute for inputs or outputs at the ECM (Electronic Control Module), BCM (Body Control Module), or any microprocessor device.

### SHORT FINDER

Short Finders are available (5-8681 or equivalent) to locate hidden shorts to ground. The short finder creates a pulsing magnetic field in the shorted circuit and shows the location of the short through body trim or sheet metal.

### FUSE TESTER

A simple tester that indicates a blown fuse is available (5-34764 or equivalent). To check a fuse the tester is applied directly to the fuse in the fuse block. Two probes contact the fuse, either into the slots of a flat fuse or to the metal ends of a glass fuse. With power on, a red LED in the tester lights if the fuse is open. The handle of the tester is a tool for removing either type of fuse.

## TROUBLESHOOTING TESTS

### TESTING FOR VOLTAGE

1. Connect one lead of a test light to a known good ground. If you are using a voltmeter, be sure it is the voltmeter's negative lead that you have connected to ground.
2. Connect the other lead of the test light or voltmeter to a selected test point (connector or terminal).
3. If the test light glows, there is voltage present. If you are using a voltmeter, note the voltage reading. It should be within one volt of measured Battery voltage. A loss of more than one volt indicates a problem.

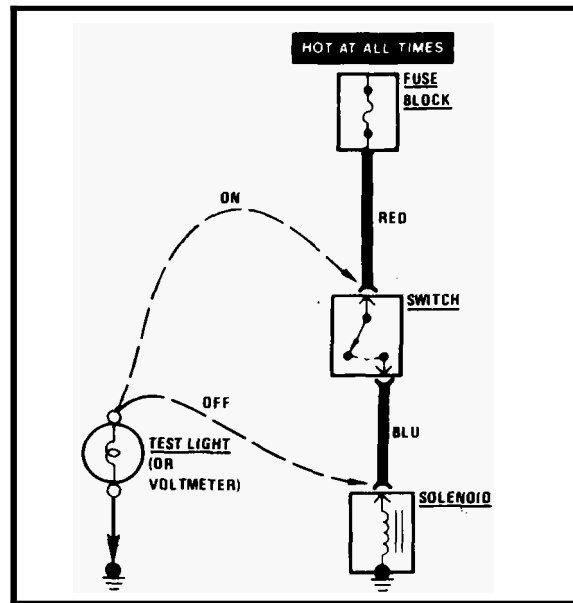

Voltage Check

### TESTING FOR CONTINUITY

1. Disconnect the car battery.
2. Connect one lead of a self-powered test light or ohmmeter to one end of the part of the circuit you wish to test.
3. Connect the other lead to the other end of the circuit.
4. If the self-powered test light glows, there is continuity. If you are using an ohmmeter, low or no resistance means good continuity.

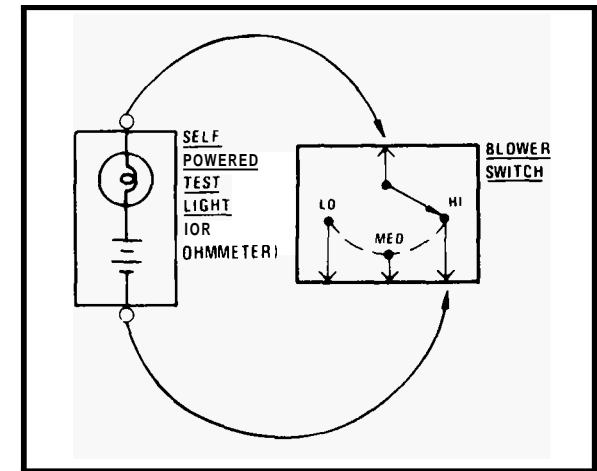

Continuity Check Through A Switch

## TESTING FOR VOLTAGE DROP

This test checks for voltage being lost along a wire, or through a connection or switch.

1. Connect the positive lead of a voltmeter to the end of the wire (or to one side of the connection or switch) which is closer to the Battery.
2. Connect the negative lead to the other end of the wire (or the other side of the connection or switch).
3. Operate the circuit.
4. The voltmeter will show the difference in voltage between the two points. A difference (or drop) of more than one volt indicates a problem.

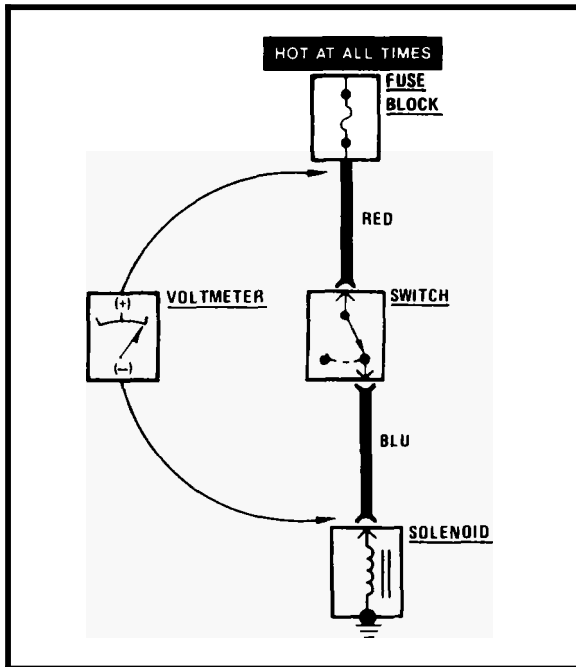

Voltage Drop Test

## TESTING FOR SHORT TO GROUND

### With a Test Light or Voltmeter

1. Remove the blown fuse and disconnect the load.
2. Connect a test light or voltmeter across the fuse terminals (be sure that the fuse is powered).
3. Beginning near the fuse block, wiggle the harness from side to side. Continue this at convenient points (about 6 inches apart) while watching the test light or voltmeter.
4. When the test light glows, or the Voltmeter registers, there is a short to ground in the wiring near that point.

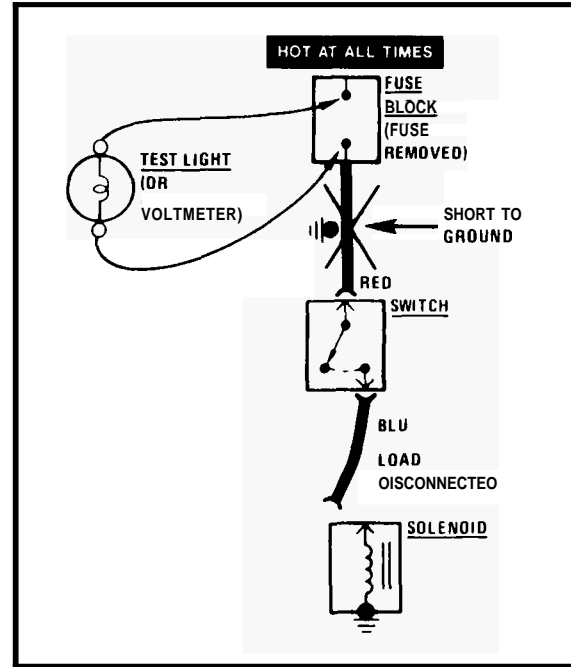

Testing For Short With Test Light or Voltmeter

### With a Self-Powered Test Light or Ohmmeter

1. Remove the blown fuse and disconnect the battery and load.
2. Connect one lead of a self-powered test light or ohmmeter to the fuse terminal on the load side.
3. Connect the other lead to a known good ground.
4. Beginning near the fuse block, wiggle the harness from side to side. Continue this at convenient points (about six inches apart) while watching the self-powered test light or ohmmeter.
5. When the self-powered test light glows, or the ohmmeter registers, there is a short to ground in the wiring near that point.

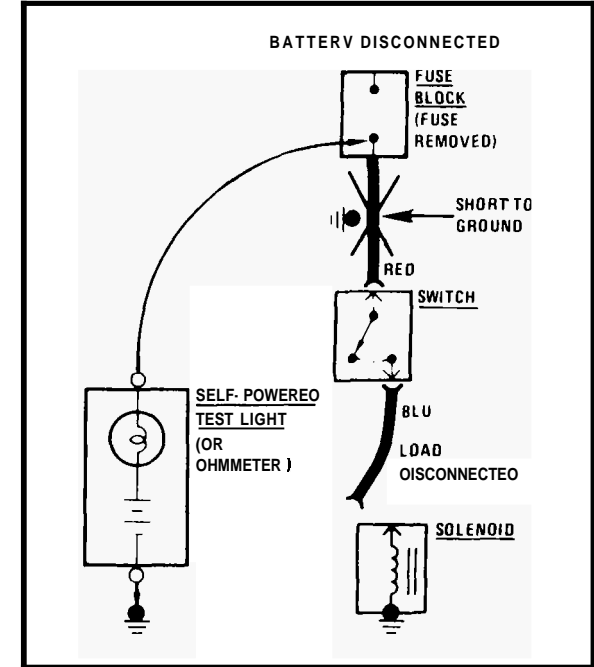

Testing For Short With Self-Powered Test Light or Ohmmeter

## TROUBLESHOOTING TESTS

### With a Short Finder

1. Remove the blown fuse, leaving the Battery connected.
2. Connect the Short Finder across the fuse terminals.
3. Close all switches in series with the circuit you are troubleshooting.
4. Operate the Short Finder. The Short Finder will pulse current to the short. This creates a pulsing magnetic field surrounding the circuit wiring between the fuse block and the short.
5. Beginning at the fuse block, slowly move the Short Finder meter along the circuit wiring. The meter will show current pulses through sheet metal and body trim. As long as the meter is between the fuse block and the short, the needle will move with each current pulse. When you have mowed the meter past the point of the short, the needle will stop moving. Examine the wiring in that area for the short to ground.

### Fuses Powering Several Loads

1. Find the schematic in Fuse Block Details (8A-11) for the fuse that has blown.
2. Open the first connector or switch leading from the fuse to each load.
3. Replace the fuse.
  - If the fuse blows, the short is in the wiring leading to the first connector or switch. Use a test light, meter, or short finder as described above.
  - If fuse does not blow, go to next step.

4. Close each connector or switch until the fuse blows, to find which circuit the short is in. Connect test lamp, meter, or short finder at the connector to the suspect circuit (disconnected) rather than at the fuse terminals.

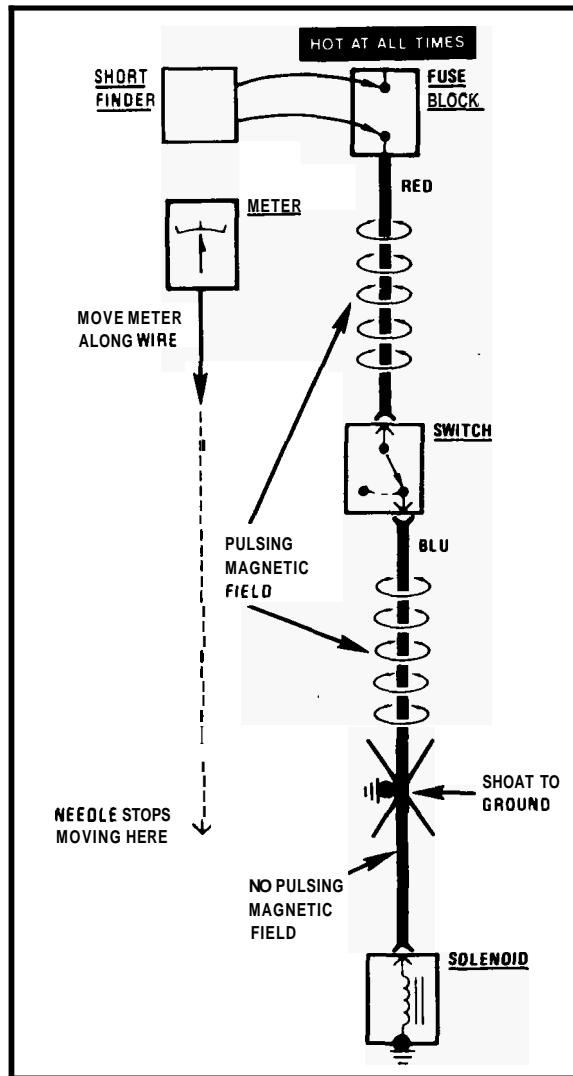

Finding Short With Short Finder

### PROPER JUMP STARTING PROCEDURES

With the use of electronic components (such as solid-state radios, electronic control modules, and others) becoming more wide-spread each model year, the potential for damage caused by improper jump starts increases. The following guidelines are presented to reduce the likelihood of such damage.

**JUMP START ONLY IF BUILT-IN HYDROMETER "EYE" ON BATTERY IS DARK.** If the "eye" is clear or yellow, do not attempt to jump start. If the "eye" is green, the Battery is charged and does not require a jump start. Both the booster and the discharged Battery should be treated carefully when using jumper cables.

**CAUTION:** Do not expose the Battery to open flame or sparks. Serious personal injury, particularly to the eyes, may result from a Battery explosion, Battery acid, or electrical burns.

- The Ignition Switch must be in OFF when connecting or disconnecting the jumper cables.
- All accessories, including the Radio, should be turned off before jump starting.
- Cable polarity must be correct. Component damage can occur if the polarity is reversed, even if only briefly.
- Connect the positive jumper cable first.. then connect the negative cable to the engine ground (not the negative terminal of the dead Battery).

## ELECTRICAL REPAIRS

This section provides instruction in the following repairs:

- Circuit Protection
- Typical Electrical Repairs
- Splicing Copper Wire
- Splicing Aluminum Wire
- Splicing Twisted/Shielded Cable
- Repairing Connectors (Except Weather Pack<sup>®</sup>) and
- Repairing Weather Pack<sup>®</sup> (Environmental) Connectors

**Note:** After any electrical repair is made, always test the circuit afterwards by operating the devices in the circuit. This confirms not only that the repair is correct, but also that it was the cause of the complaint.

## CIRCUIT PROTECTION

All electrical circuits are protected against excessive loads which might occur because of shorts or overloads in the wiring system. Such protection is provided by a fuse, circuit breaker, or fusible link.

### Fuses

The most common method of automotive wiring circuit protection is the fuse. Whenever there is an excessive amount of current flowing through a circuit the fusible element will melt and create an open or incomplete circuit

(see Figure 1). Fuses are a "one time" protection device and must be replaced each time the circuit is overloaded.

Auto-fuses are color coded. The standardized color identification and ratings are shown in Figure 2.

For service replacement, non-color coded fuses of the same respective current rating can be used. The current rating of each fuse is molded into its head.

To determine whether or not an auto-fuse is blown, remove the suspect fuse and examine the element in the fuse for a break. (see Figure 1). If the element is broken, replace the fuse with one of equal current rating.

There are, however, additional specific circuits with in-line fuses. In-line fuses are located within the individual wiring harness. They are usually housed in spring-loaded, twist-type receptacles.

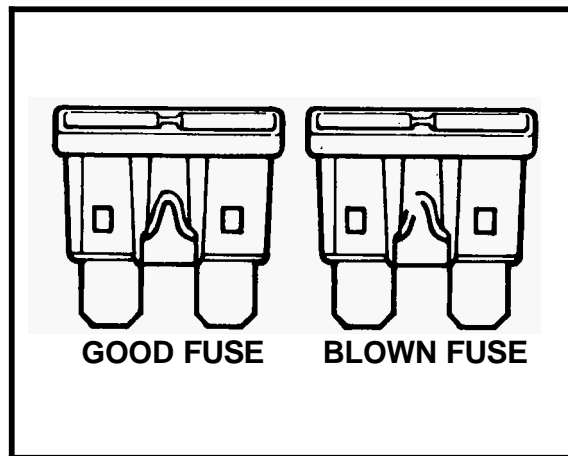

Figure 1 • Sample Fuses

CURRENT RATING (AMPERES)	COLOR
3	VIOLET
5	TAN
7.5	BROWN
10	RED
15	BLUE
20	YELLOW
25	WHITE
30	GREEN

Figure 2 - Fuse Rating And Color

### Circuit Breakers

A circuit breaker is a protective device designed to open the circuit when a current load is in excess of rated breaker capacity. If there is a short or other type of overload condition in the circuit, the excessive current will open the circuit between the circuit breaker terminals. The circuit breaker will remain open until the trouble is found and corrected. The circuit breaker will close automatically when the excessive current is removed. The condition of a circuit breaker may be verified by removing it from the circuit and checking the resistance. A good circuit breaker will have less than 1ohm resistance between the two terminals.

## Fusible Links

In addition to circuit breakers and fuses, some circuits use fusible links to protect the wiring. Like fuses, fusible links are "onetime" protection devices that will melt and create an open circuit (see Figure 3).

Not all fusible link open circuits can be detected by observation. Always inspect that there is Battery voltage past the fusible link to verify continuity.

Fusible links are used instead of a fuse in wiring circuits that are not normally fused, such as the ignition circuit. Each fusible link is four wire-gauge sizes smaller than the cable it is designed to protect. Links are marked on the insulation with wire-gauge size because the heavy insulation makes the link appear to be a heavier gauge than it actually is. The same wire size fusible link must be used when replacing a blown fusible link.

Fusible links are available with two types of insulation: Hypalon<sup>®</sup> and Silicone/GXL (SIL/GXL). Service fusible links made with SIL/GXL may be used to replace either Hypalon<sup>®</sup> or SIL/GXL fusible links. Service fusible links made with Hypalon<sup>®</sup> may only be used to replace Hypalon<sup>®</sup> fusible links. To determine the fusible link type: nick the insulation of the blown fusible link with a knife. SIL/GXL will have a white inner core under the outer color. Hypalon<sup>®</sup> insulation is one color. Service fusible links are available in many lengths. Choose the shortest length that is suitable. If the fusible link is to be cut from a spool, NEVER make a fusible link longer than 228 mm (9 in).

**CAUTION:** Fusible links cut longer than 228 mm (9 in) will not provide sufficient overload protection.

To replace a damaged fusible link, cut it off beyond the splice. Replace with a repair link. When connecting the repair link, strip wire and use staking-type pliers to crimp the splice securely in two places (see Figure 4). For more details on splicing procedures see Splicing Copper Wire.

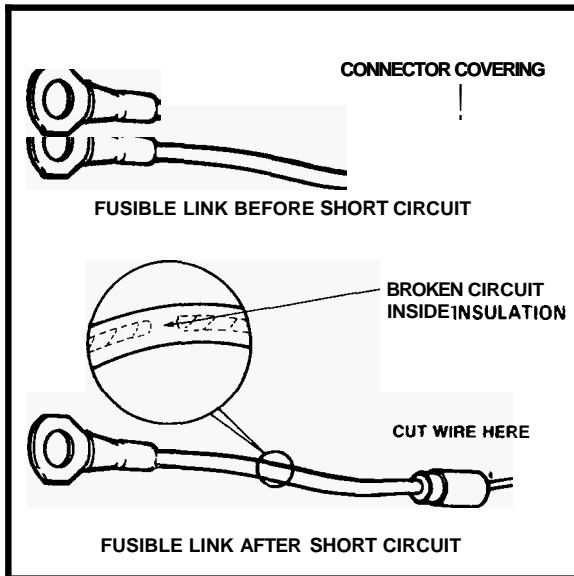

Figure 3 · Good And Damaged Fusible Links

To replace a damaged fusible link which feeds two harness wires, cut them both off beyond the splice. Use two repair links, one spliced to each harness wire (see Figure 5).

**TYPICAL ELECTRICAL REPAIRS**

An open circuit is an incomplete circuit. Power cannot reach the load or reach ground. If a circuit is open, active components do not energize. A short circuit is an unwanted connection between one part of the circuit and either ground or another part of the circuit. A short circuit causes a fuse to blow or a circuit breaker to open.

**Short Circuits Caused by Damaged Wire Insulation**

- Locate the damaged wire.
- Find and correct the cause of the wire insulation damage.
- For minor damage, tape over the wire. If damage is more extensive, replace the faulty segment of the wire. (Refer to the splicing instructions for copper, aluminum, or shielded cable for the correct splicing procedure.)

**SPLICING COPPER WIRE**

**Step One: Open the Harness**

If the harness is taped, remove the tape. To avoid wire insulation damage, use a sewing "seam ripper" to cut open the harness (available from sewing supply stores).

If the harness has a black plastic conduit, simply pull out the desired wire. Note that aluminum wire is enclosed in brown conduit. Refer to Splicing Aluminum Wire if necessary.

**Step Two: Cut the Wire**

Begin by cutting as little wire off the harness as possible. You may need the extra length of wire later if you decide to cut more wire off to change the location of a splice. You may have to adjust splice locations to make certain that each splice is at least 40mm (1 1/2") away from other splices, harness branches, or connectors.

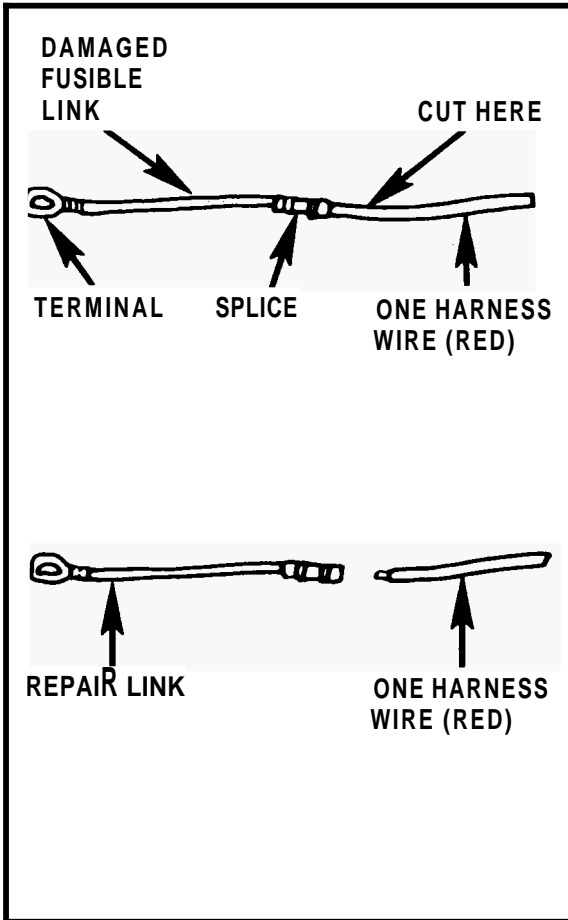

Figure 4 - Single Wire Feed Fusible Link

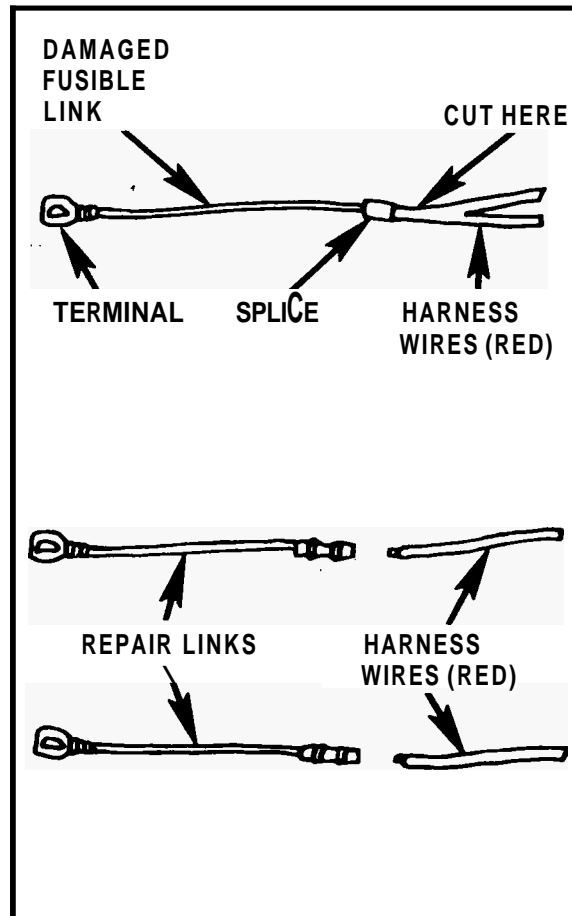

Figure 5 - Double Wire Feed Fusible Link



### Step Three: Strip the Insulation

When replacing a wire, use a wire of the same size as the original wire or larger. The schematics list wire size in metric units. The following table (see Figure 6) shows the commercial (AWG) wire sizes that can be used to replace each metric wire size. Each AWG size is either equal to or larger than the equivalent metric size.

METRIC WIRE SIZES	AWG SIZES
22	24
35	22
5	20
8	18
1.0	16
2.0	14
3.0	12
5.0	10
8.0	8
13.0	6
19.0	4
32.0	2

Figure 6 - Wire Size Conversion Table

To find the correct wire size either find the wire on the schematic page and convert the metric size to the AWG size, or use an AWG wire gage.

If you aren't sure of the wire size, start with the largest opening in your wire stripper and work down until you get a clean strip of the insulation. Be careful to avoid nicking or cutting any of the wires.

Check the stripped wire for nicks or cut strands. If the wire is damaged, repeat the procedure on a new section of wire. The two stripped wire ends should be equal in length.

### Step Four: Crimp the Wires

Select the proper clip to secure the splice. To determine the proper clip size for the wire being spliced, follow the directions included with your clips. Select the correct anvil on the crimper. (On most crimpers your choice is limited to either a small or large anvil.) Overlap the two stripped wire ends and hold them between your thumb and forefinger as shown in Figure 7. Then, center the splice clip under the stripped wires and hold it in place.

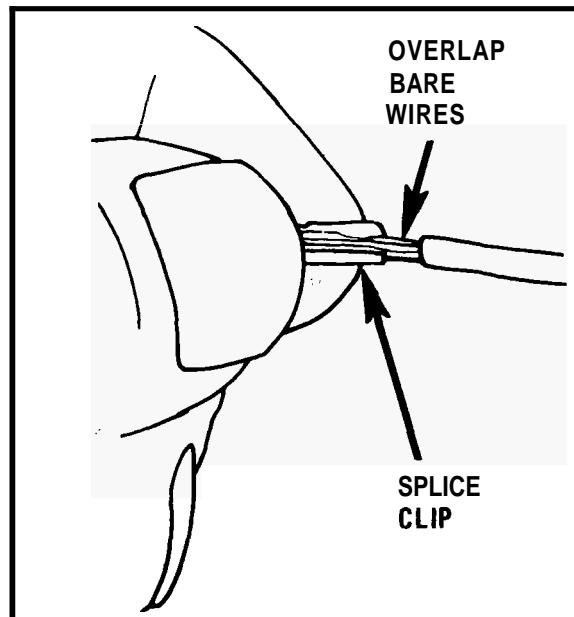

Figure 7 - Centering The Splice Clip

- Open the crimping tool to its full width and rest one handle on a firm flat surface.
- Center the back of the splice clip on the proper anvil and close the crimping tool to the point where the former touches the wings of the clip.

- Make sure that the clip and wires are still in the correct position. Then, apply steady pressure until the crimping tool closes (see Figure 8).

Before crimping the ends of the clip, be sure that:

- The wires extend beyond the clip in each direction.
- No strands of wire are cut loose, and
- No insulation is caught under the clip.

Crimp the splice again, once on each end. Do not let the crimping tool extend beyond the edge of the clip or you may damage or nick the wires (see Figure 9).

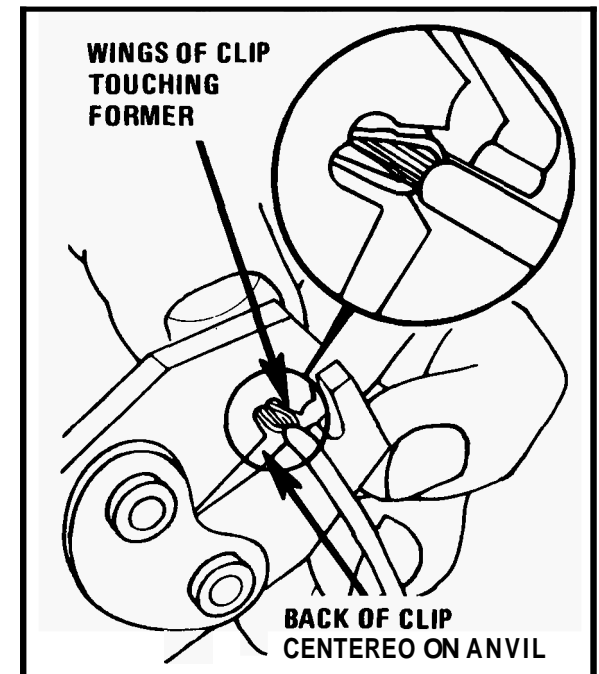

Figure 8 - Crimping The Splice Clip

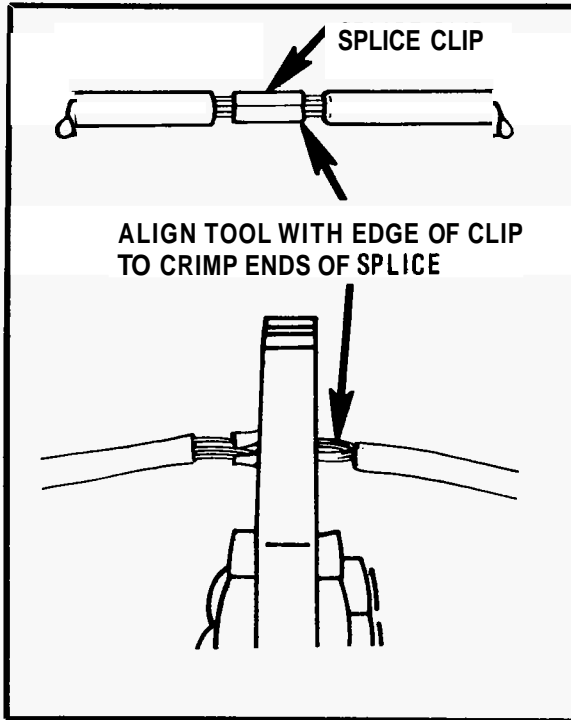

Figure 9 - Completing The Crimp

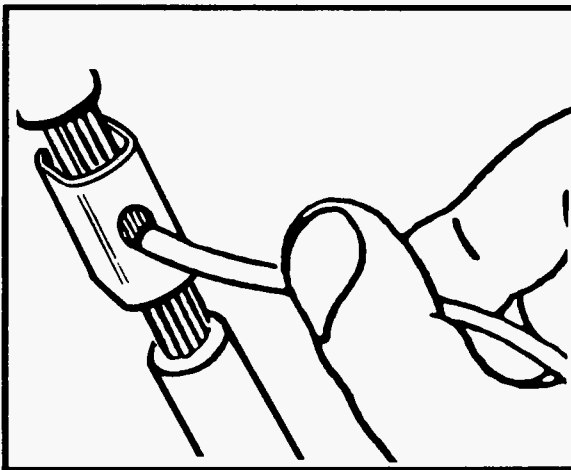

Figure 10 - Applying The Solder

**Step Five: Solder**

Apply 60140 rosin core solder to the opening in the back of the clip (see Figure 10). Follow the manufacturer's instructions for the solder equipment you are using.

**Step Six: Tape the Splice**

Center and roll the splicing tape. The tape should cover the entire splice. Roll on enough tape to duplicate the thickness of the insulation on the existing wires. Do not flag the tape. Flagged tape may not provide enough insulation, and the flagged ends will tangle with the other wires in the harness (see Figure 11).

If the wire does not belong in a conduit or other harness covering, tape the wire again. Use a winding motion to cover the first piece of tape (see Figure 12).

**SPlicing ALUMINUM WIRE**

General Motors cars have a front body wiring harness made of 2.0 metric and 1.0 metric (14 and 16 gauge) insulated solid cable aluminum wires. These wires are enclosed in a brown solid plastic conduit from behind the instrument panel to the rear of the car.

A special repair kit (1684873-GR.2.530-KIT-ALUM-WIRE TERMINAL REPAIR) is available to help make repairs on aluminum wires. This kit contains materials and instructions that can be used either to splice wire or crimp on new terminals. The kit includes the following parts:

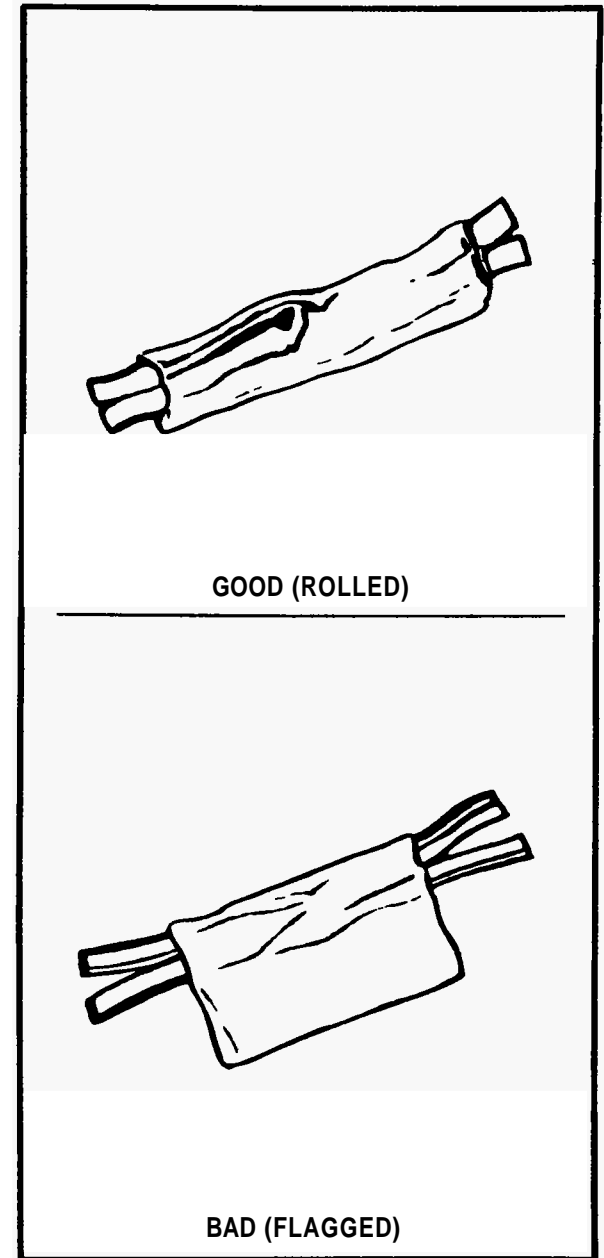

Figure 11 - Roper First Taping

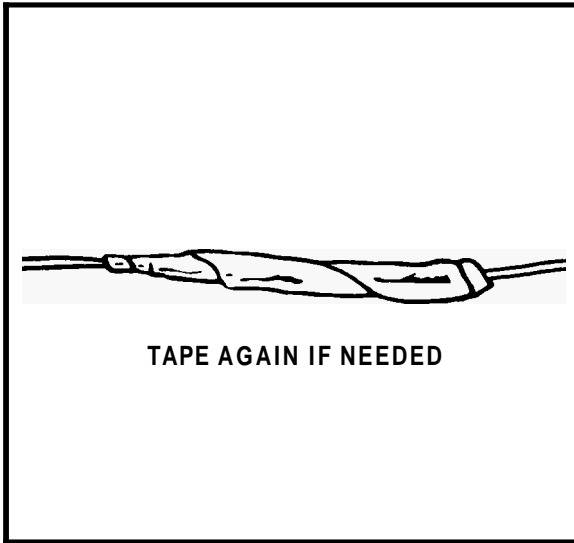

Figure 12 - Proper Second Taping

- Small cylindrical metal splice clips.
- A plastic tube of petroleum jelly.
- Ten 2.0 metric (14 gauge) DK GHN leads: 150mm (6") long with terminals.
- Ten 1.0 metric (16 gauge) BRN leads: 150 mm (6") long with terminals.

Use of the special materials in this kit will help prevent galvanic corrosion. Galvanic corrosion causes increased resistance between the terminal and wire, or the splice clip and wire, or both. Increased resistance would affect the operation of the electrical components in the repaired circuit.

**Step One: Open the Harness**

Because the harness has a solid plastic conduit, simply cut the conduit open with diagonal cutters and pull out the desired wire. Be careful not to damage any of the wires when cutting open the conduit.

**Step Two: Cut the Wire**

Begin by cutting as little wire off the harness as possible. You may need the extra length of wire later if you decide to cut more wire off to change the location of a splice. You may have to adjust splice locations to make certain that each splice is at least 40mm (1 1/2") away from the other splices, harness branches, or connectors.

**Step Three: Strip the Insulation**

When replacing a wire or lead, use a wire of the same size as the original wire, or larger. Look up the metric wire size on the schematic and select the proper-sized leads from the special repair kit. Remember that the wires in this harness can only be one of two sizes-2.0 metric or 1.0 metric (14 or 16 gauge).

Use wire strippers of the proper gauge to strip approximately 6mm (1/4") of insulation from each wire end.

When stripping the outer jacket from the aluminum wire core, be careful not to nick or damage the core. A damaged core will weaken the assembly at this point.

**Step Four: Coating the Splice/Terminal**

To prevent corrosion, apply a generous coating of petroleum jelly to the splice area. If you are replacing a lead, also thoroughly coat the terminal crimp area and aluminum core with petroleum jelly. Both areas are shown in Figure 13 and identified with the letter "A."

**Step Five: Crimp the Wires**

- Select the proper-sized splice clip (follow the instructions included in the special repair kit).
- Place one wire end in each end of the splice clip.
- Crimp the clip firmly to the wire using 10" slip joint pliers. Do NOT solder the splice (see Figure 14).
- Repeat this procedure for the second wire or lead in the splice clip.

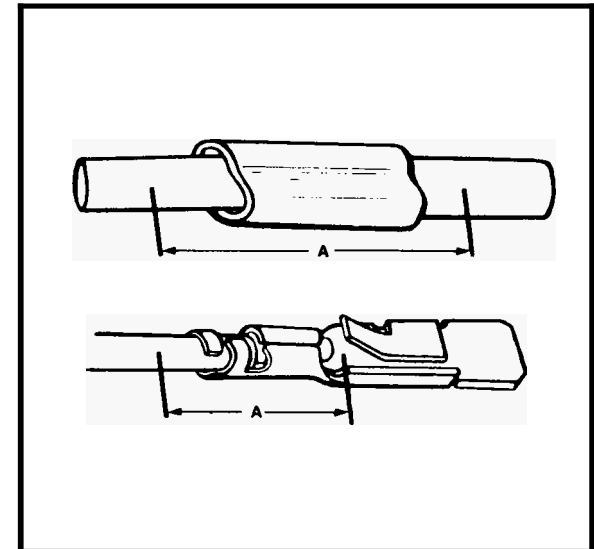

Figure 13 - Where To Apply Petroleum Jelly

## Step Six: Tape Splice/Insert Terminal

Tape over both the splice clip and the petroleum jelly to seal out moisture and insulate the splice (see Figure 15). If you have replaced a lead, do not tape over the terminal crimp area but insert the lead into the connector body.

## SPLICING TWISTED/SHIELDED CABLE

Twisted/shielded cable is sometimes used to protect wiring from electrical noise (stray signals). For example, two-conductor cable of this construction is used between the ECM and the distributor. See Figure 16 for a breakdown of twisted/shielded cable construction.

### Step One: Remove Outer Jacket

Remove the outer jacket and discard it. Be careful to avoid cutting into the drain wire or the mylar tape.

### Step Two: Unwrap the Tape

Unwrap the aluminum/mylar tape, but do not remove it. The tape will be used to rewrap the twisted conductors after the splices have been made.

### Step Three: Prepare the Splice

Untwist the conductors. Then, prepare the splice by following the splicing instructions for copper wire presented earlier. Remember to stagger splices to avoid shorts (see Figure 17).

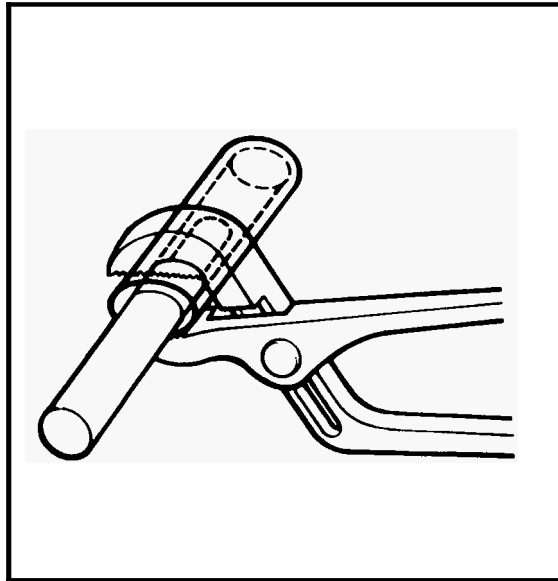

Figure 14 - Crimping The First Half Of The Splice Clip (Aluminum Wire)

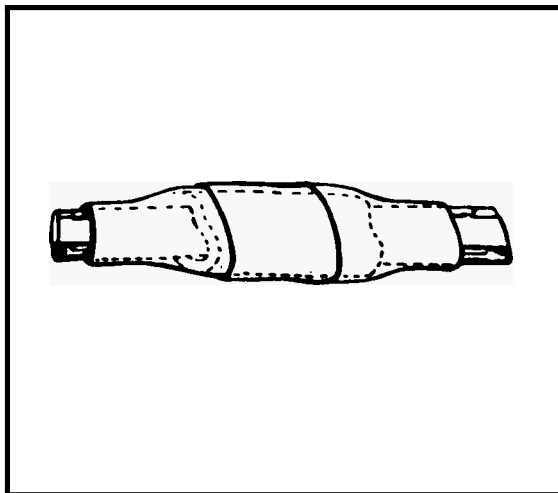

Figure 15 - The Tape Covers The Splice Clip And The Petroleum Jelly To Seal And Insulate

### Step Four: Re-Assemble the Cable

After you have spliced and taped each wire, rewrap the conductors with the mylar tape. Be careful to avoid wrapping the drain wire in the tape.

Next, splice the drain wire following the splicing instructions for copper wire. Then, wrap the drain wire around the conductors and mylar tape (see Figure 18).

### Step Five: Tape the Cable

Tape over the entire cable using a winding motion (see Figure 19). This tape will replace the section of the jacket you removed to make the repair.

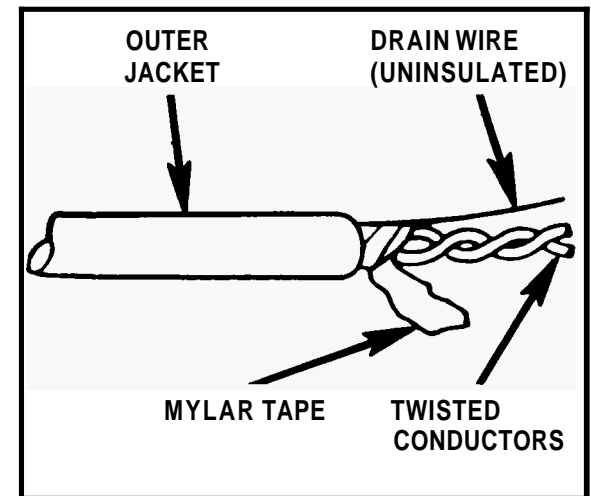

Figure 16 - Twisted/Shielded Cable

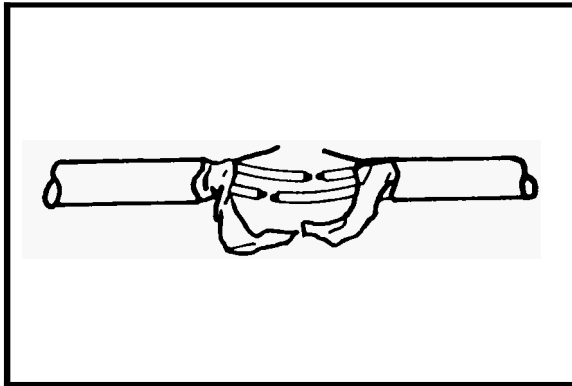

Figure 17 - The Untwisted Conductors

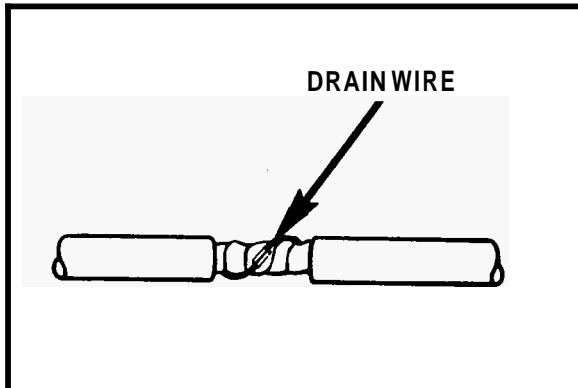

Figure 18 - The Re-Assembled Cable

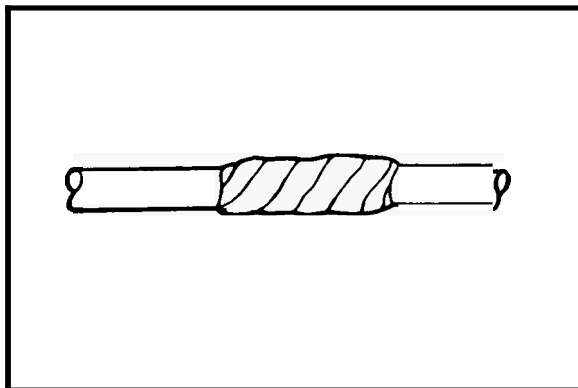

Figure 19 - Proper Taping

## REPAIRING CONNECTORS

### (Except Weather Pack® and Metri-Pack Series 150 Pull-to-Seat Type)

The following general repair procedures can be used for High Density, Printed Circuit Type, Bulkhead Type, and connector. Prior to starting any repairs, separate connector halves and remove any terminal covers or retainers.

Instruction in the disassembly, repair, and assembly of connectors follows. Consult the figures for details on each specific type of connector. The instruction is divided into steps. Only perform those steps necessary to make the repair.

#### Step One: Remove the Lead

Depress the terminal locking tang using the proper size pick.

**CAUTION:** Do not place fingers or other parts of the body next to or around the back of the connector. If too much force is used, the pick and terminal both could be pushed out the back of the connector and cause injury.

- Place the pick between the locking tang of the terminal and the plastic of the connector body.
- Ease the lead back enough to release the locking tang.
- Pull the pick out.
- Gently pull the lead out of the back of the connector body.

#### Step Two: Re-Form the Locking Tang

If the lead and terminal are in good condition, reform the locking tang:

- Hold the lead firmly to prevent the splice between the terminal and the wire from flexing.
- Use the pick to bend the locking tang back into its original shape. Also check to see that the remainder of the terminal is still in its original shape.

#### Step Three: Make the Repair

When you make a repair, use the correct types of terminals and wires.

- Attach a new wire or a new terminal using the procedures in Splicing Copper Wire or Splicing Aluminum Wire.

#### Step Four: Insert the Lead

Before inserting the lead, make certain that the terminal is correctly shaped. Be careful to insert terminals in their proper locations.

- Gently insert the lead from the back.

The terminal should stop or "catch" about halfway through the connector body.

**Note:** With bulkhead connectors, in many cavities it is possible for the terminal to be inserted in two ways. Be sure it is inserted in the same direction as it was removed, or to mate correctly with the facing terminal.

## REPAIR PROCEDURES

- Pushback and forth gently on the lead to be sure the terminal is held in place in both directions. If the terminal easily pushes or pulls out, review Step Two: "Re-Form the Locking Tang."

Before mating the connector halves replace any terminal covers or retainers that were removed, and apply grease to prevent corrosion.

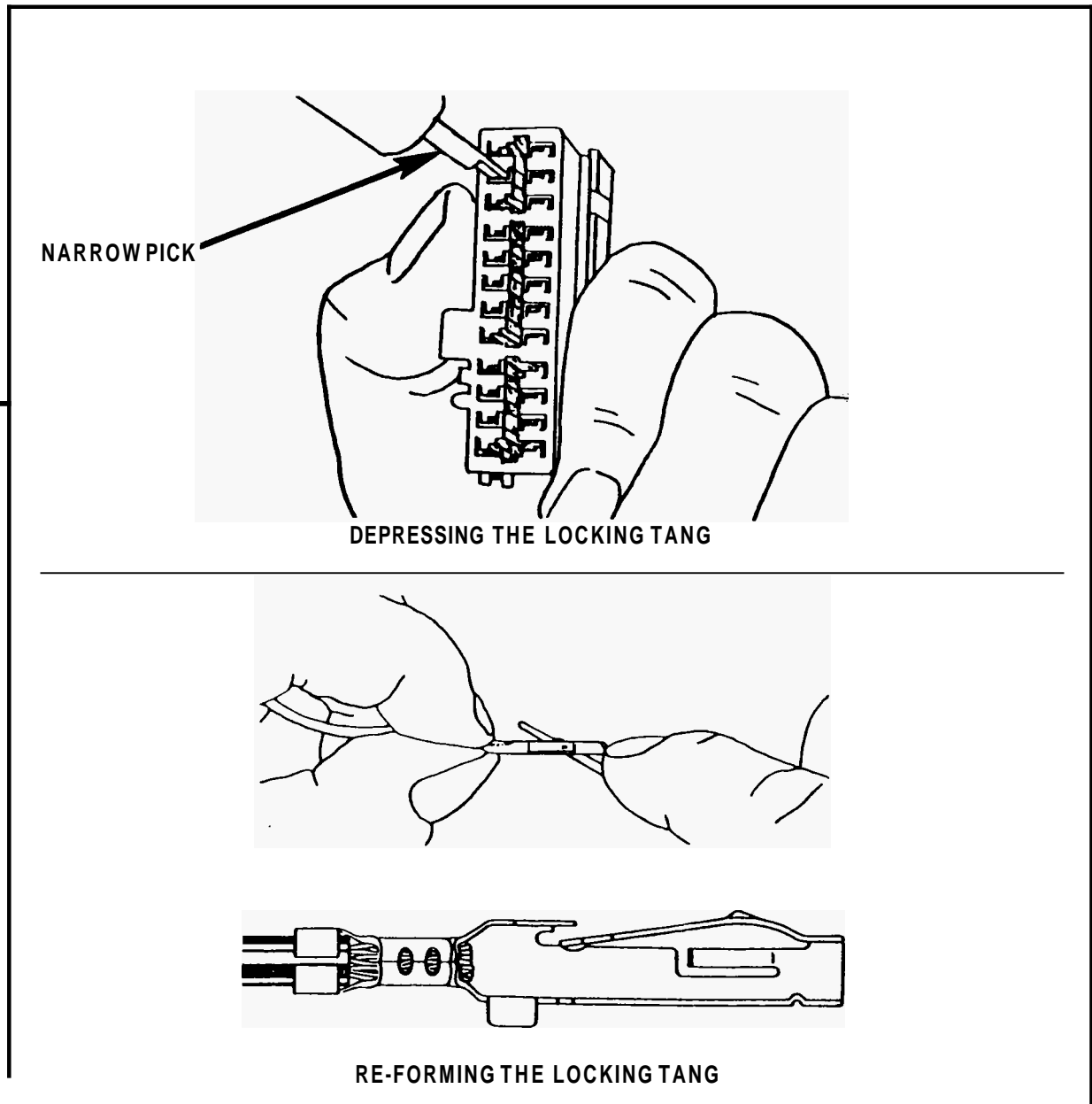
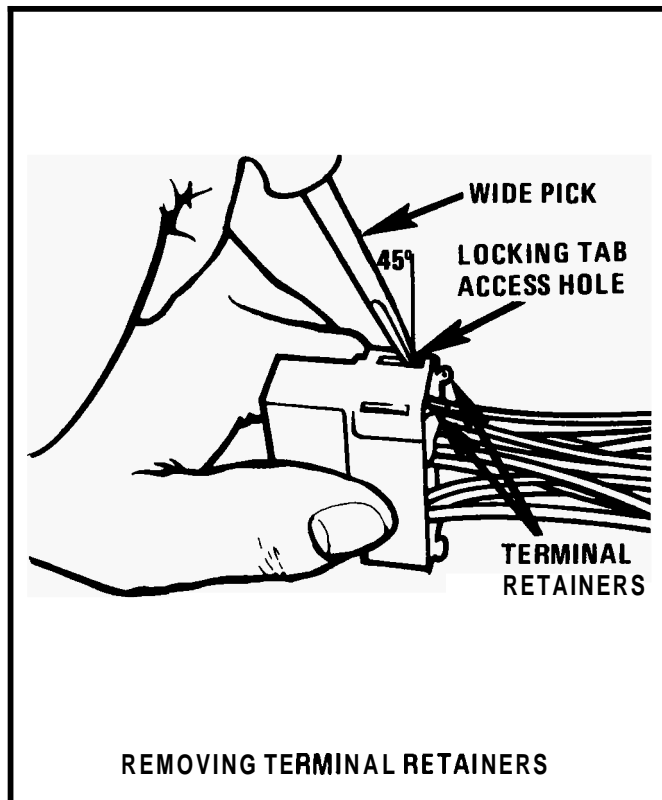

Figure 20- High Density Connectors

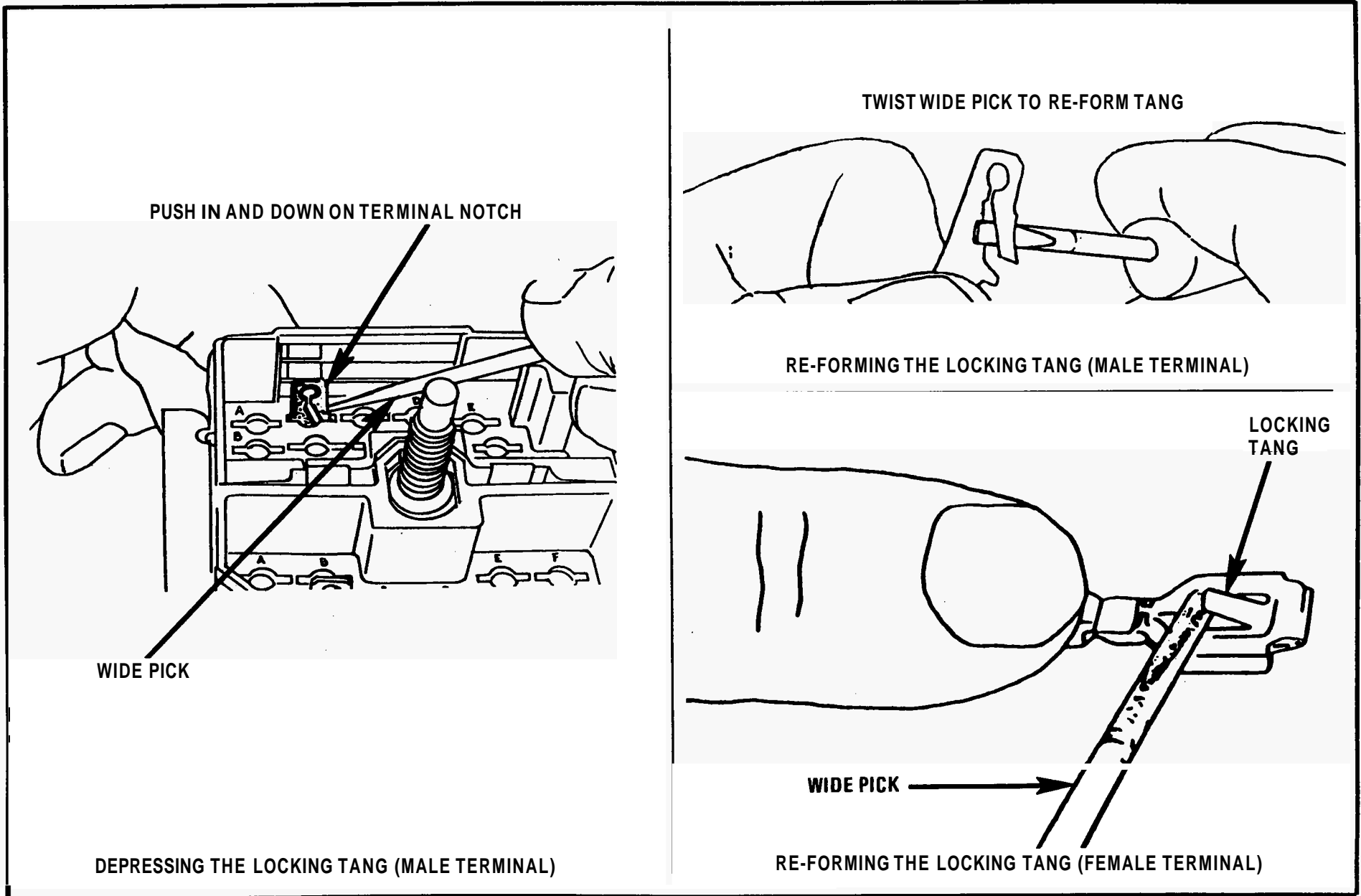
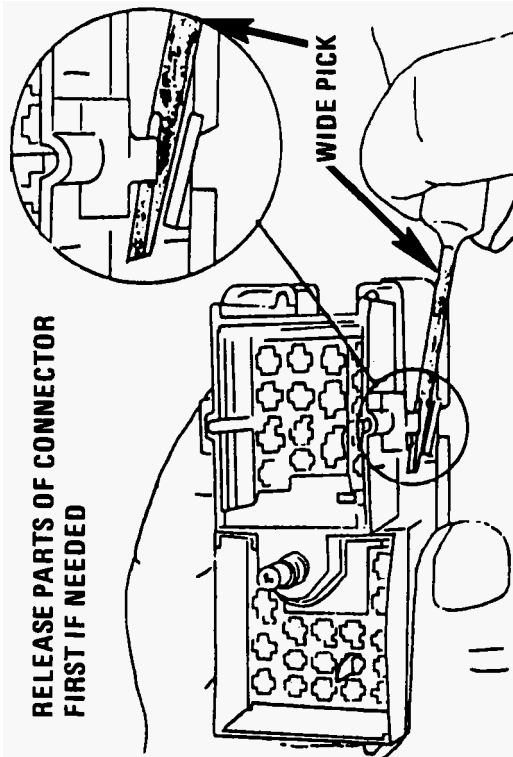

Figure 21 - Bulkhead Type Connectors

REPAIR PROCEDURES

RELEASE PARTS OF CONNECTOR FIRST IF NEEDED



REMOVING TERMINAL RETAINERS (MPL & T&S MINIPLS)

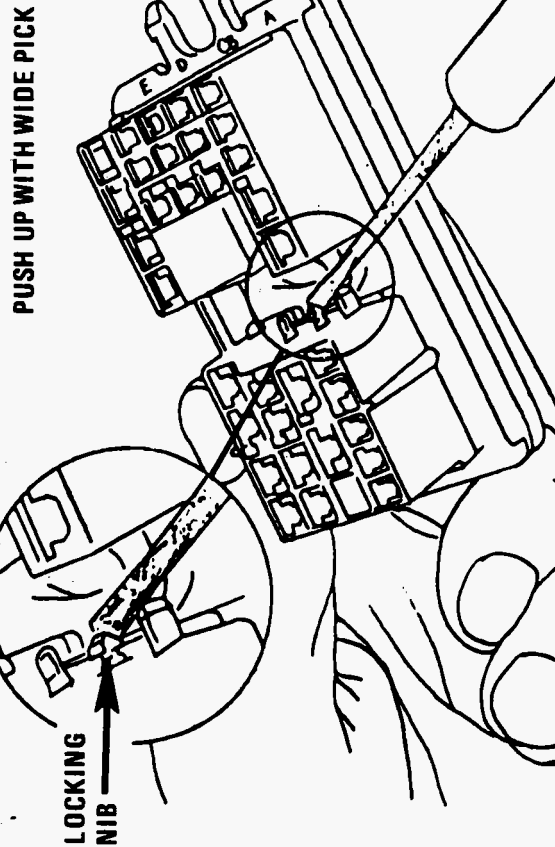

REMOVING TERMINAL RETAINERS (FEMALE TERMINALS)

LOCKING TANG

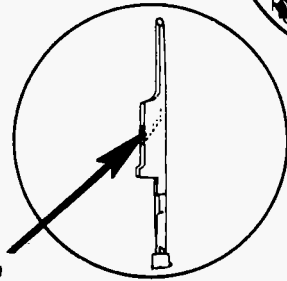

LOCKING TANG

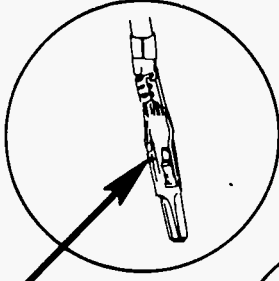

LOCKING NIB

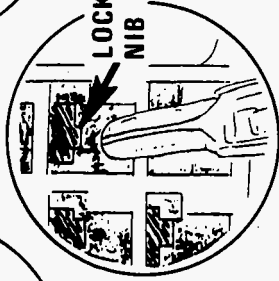

RE-FORMING THE LOCKING TANG (MALE TERMINAL)

NOTCH

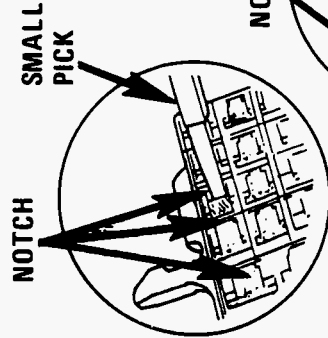

SMALL PICK

NOTCH

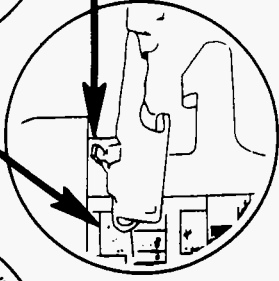

TANG

LOCKING TANG

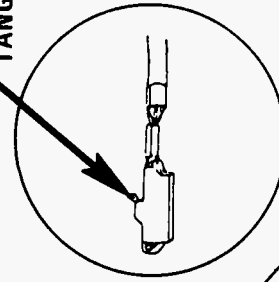

RE-FORMING THE LOCKING TANG (FEMALE TERMINAL)

Figure 22 - Metri-pack Type Connectors - Push-To-Seat Type



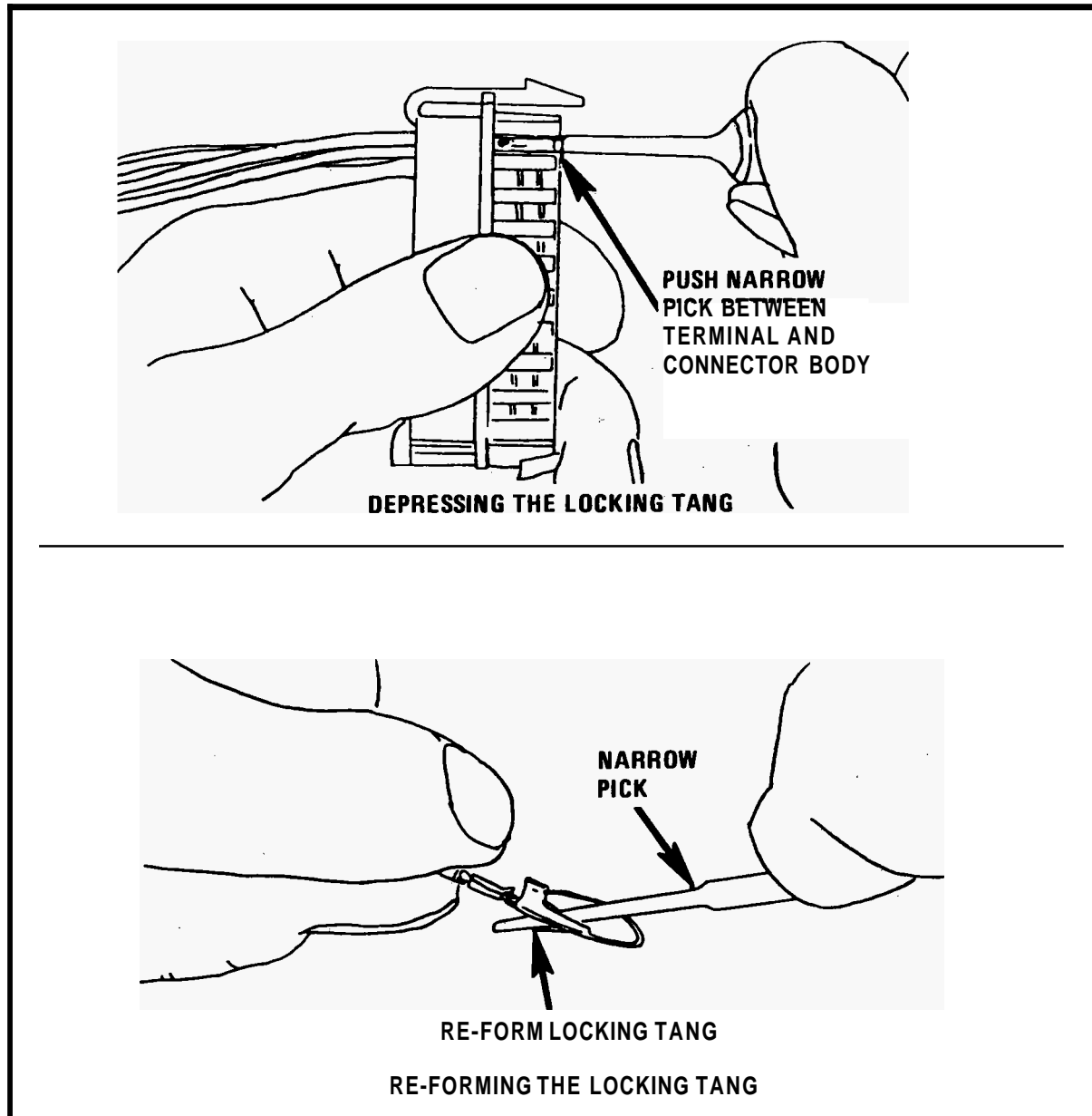

Figure 23 - Printed Circuit Type Connectors

### REPAIRING WEATHER PACK® (Environmental) CONNECTORS

Weather Pack® -or weatherproof-connectors provide environmental protection on certain electrical circuits. This protection consists of a moisture-proof rubber flexible seal between the two connector halves and rubber cable seals attached to each terminal. The terminals and the cable seals are secured by a hinged secondary lock on small Weather Pack® connectors and by plastic terminal retainers on large Weather Pack® connectors.

If a Weather Pack® connector requires repair, do not replace the Weather Pack® parts with other types of connectors and terminals. **Also**, do not omit either the large seal or the cable seals when making a repair.

Instruction in the disassembly, repair, and assembly of both small and large Weather Pack® connectors follows. The instruction is divided into steps. Only perform those steps necessary to make the repair.

#### Step One: Separate the Connector Halves

To separate a large connector, unscrew the bolt in the center of the connector body. Then pull the two halves apart. To separate a small connector, simply pull up on the primary lock and simultaneously pull the two halves apart.

## Step Two: Remove the Terminal Retainer(s) (Large Connectors)/Open the Secondary Locks (Small Connectors)

To remove a terminal retainer, press a wide pick at a 45° angle against the locking nib (see Figure 24). Push the nib up as far as possible. Then, pull the retainer out.

To open the secondary locks on small connectors, flip down the lock hinges as shown in Figure 25.

## Step Three: Remove the Lead

Depress the terminal locking tangs using a Weather Pack® pick (J28742-A or the equivalent):

- Push the hollow cylinder of the pick into the terminal cavity from the front until it stops (see Figures 26 and 27). The pick should surround the terminal (see Figure 28 for drawings of locking tangs).
- Pull the pick out.
- Gently pull the lead out of the back of the connector body.

Note that the male connector body half contains female terminals and the female half houses male terminals.

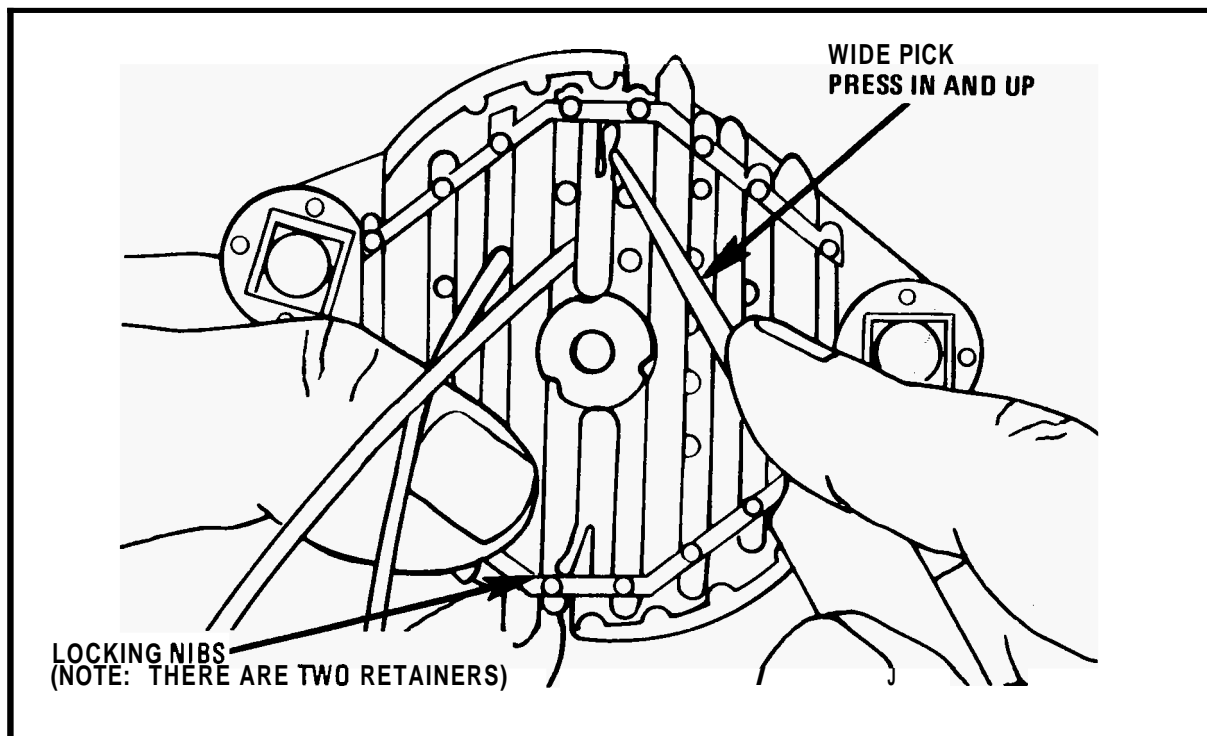

Figure 24- Releasing the Terminal Retainers (Large Connectors)

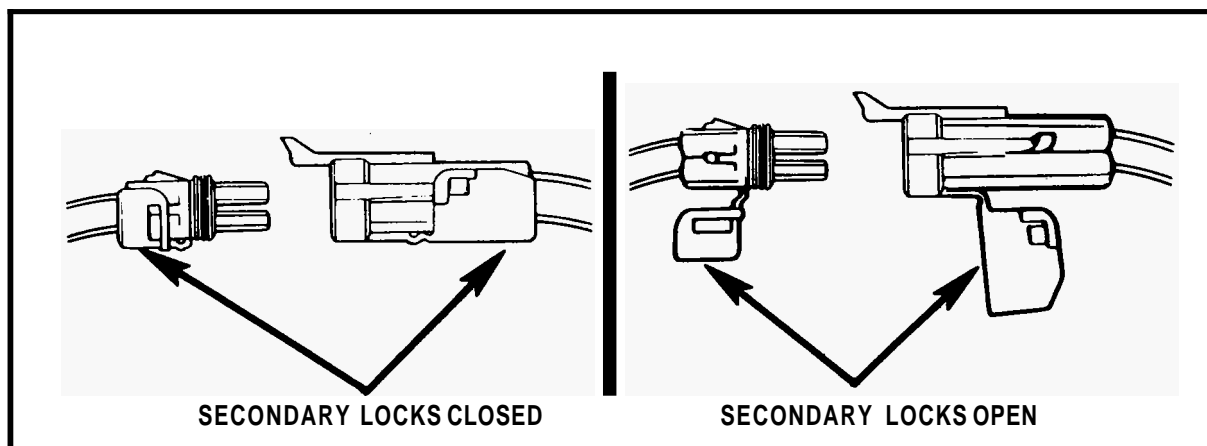

Figure 25- Opening the Secondary Locks (Small Connectors)

## REPAIR PROCEDURES

### Step Four: Re-Form the Locking Tang

If the lead and terminal are in good condition, re-form the locking tang.

- Hold the lead firmly to prevent the splice between the terminal and the wire from flexing.
- Use the pick (528742-A or the equivalent) to bend the locking tang back into its original shape (see Figure 28). Also, check to see that the remainder of the terminal is still in its original shape. (See Step Six for instruction in inserting the lead.)

### Step Five: Make the Repair

When you make a repair, use the correct types of terminals, wires, and seals.

To add a new lead, cut the wire and crimp and solder on the weather-pack lead assembly (see Figure 29) using rosin core solder. (Follow the instructions for splicing wire outlined earlier in this section for a review of splicing procedures.)

If Weather Pack® lead assemblies are not available, splice a new terminal and cable seal onto the existing wire.

- Cut the wire immediately behind the cable seal.
- Slip the new cable seal onto the wire and push it back out of the way.
- Strip 5.0mm (3/16") of insulation from the wire.

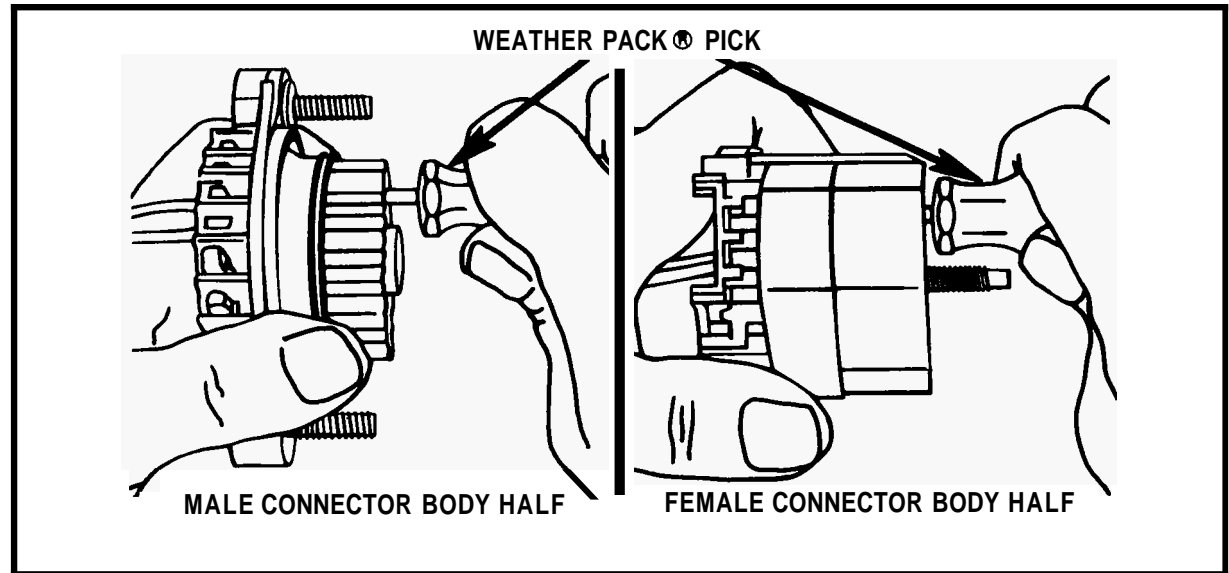

Figure 26 - Releasing The Terminal Locking Tangs (Large Connector)

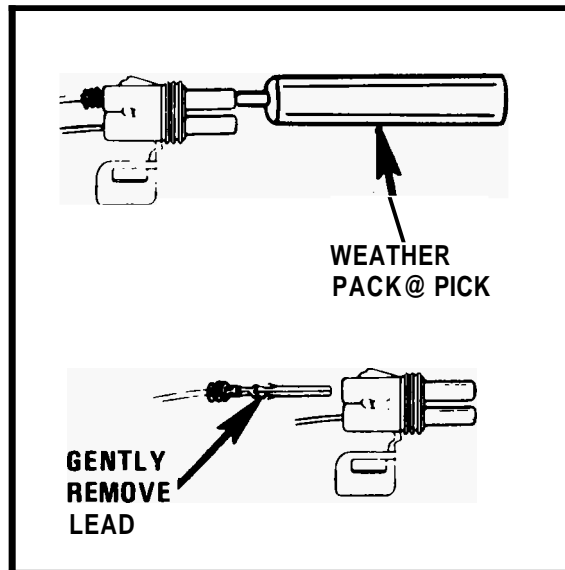

Figure 27 - Releasing The Terminal locking Tangs (Small Connectors)

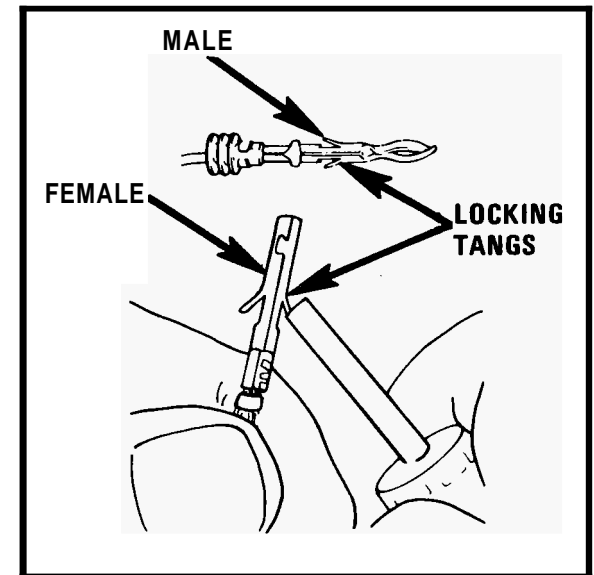

Figure 28 - Re-Forming The Locking Tang

## REPAIR PROCEDURES

- Crimp the new terminal over the copper strands (core crimp) as shown in Figure 30. (Use a standard crimping tool—number 525563 in the Kent-Moore catalog.)
- Solder with rosin core solder.
- Move the cable seal to edge of the insulation.
- Crimp the grips at the end of the terminal around the cable seal and insulated wire as shown in Figure 30 (insulation crimp). Apply light pressure for this crimp.

Remember to use the proper types of terminals and seals for this repair.

### Step Six: Insert the Lead

Before inserting the lead, make certain that the terminal is correctly shaped (see Figure 28). Then, gently insert the lead from the back. The terminal should stop or "catch" about halfway through the connector body. Gently push back and forth on the lead to be sure the terminal is held in place in both directions. If the terminal easily pushes or pulls out, review Step Four; "Re-Form the Locking Tang."

Be careful to insert leads in their proper locations.

### Step Seven: Replace the Terminal Retainer(s) (Large Connectors)/Secondary Locks (Small Connectors)

Replace the terminal retainers by slipping the retainer halves into the connector body (as shown in Figure 31).

To close the secondary locks on small connectors, flip the hinges back to their original positions (see Figure 32).

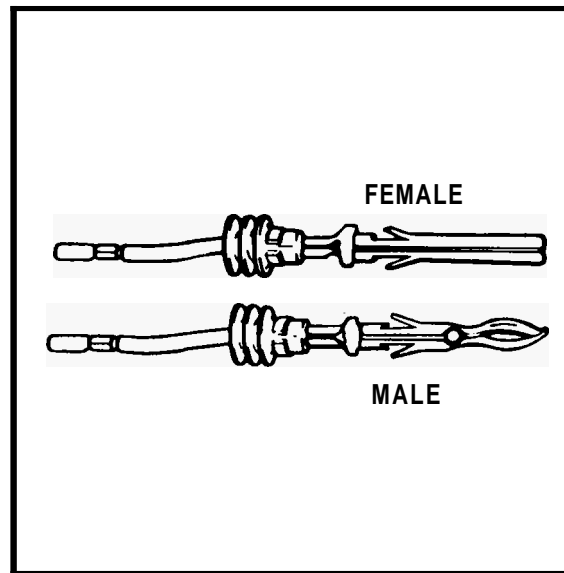

Figure 29 - Lead Assemblies

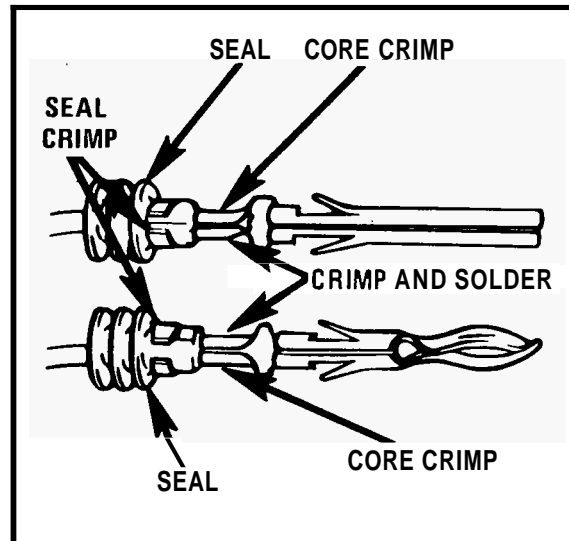

Figure 30 - Replacing The Terminal

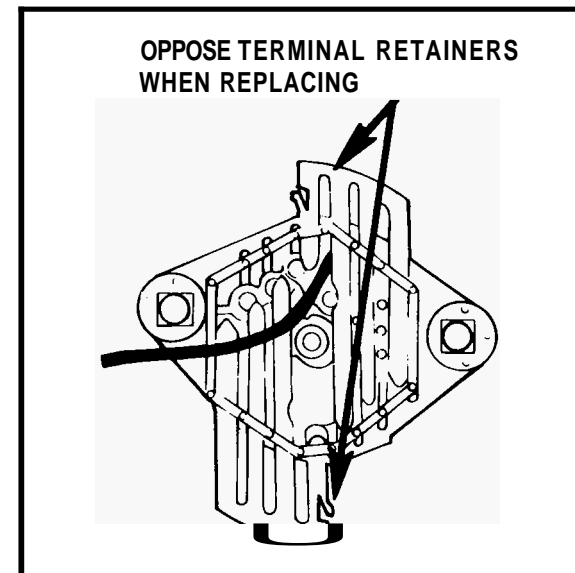

Figure 31 - Replacing The Terminal Retainers (Large Connectors)

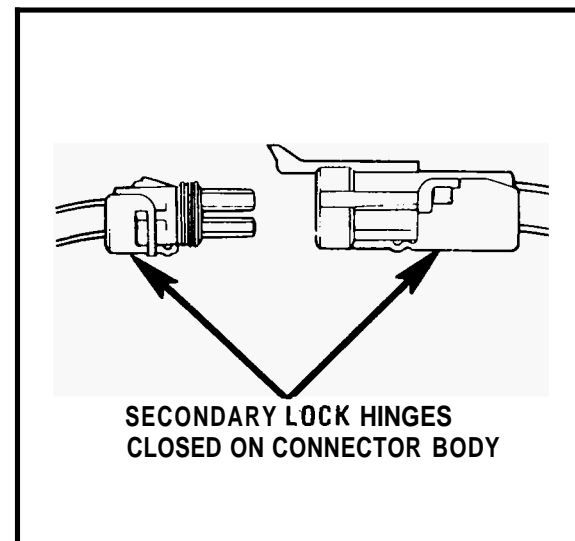

Figure 32 - Closing The Secondary Locks

# REPAIRING METRI-PACK SERIES 150 CONNECTORS

## REPAIRING METRI-PACK SERIES 150 CONNECTORS (Pull-to-Seat Type)

Metri-Pack connectors are used to connect various sensors such as the cam, crankshaft and coolant sensors to primary harnesses in the engine compartment. The Metri-Pack connector consists of three parts (see Figure 29): a Pull to Seat type terminal, a connector body and a rubber seal which is inserted in the back of the connector body to provide environmental protection.

Do not replace the Metri-Pack parts with parts of other types of connectors and terminals or omit the environmental seals when repairing Metri-Pack connectors.

Repair instructions are divided into two steps, connector disassembly and terminal removal and connector assembly and terminal insertion. (Refer to figures 33 to 36)

### Step One: Connector Disassembly and Terminal Removal

Insert tool **BT-8446** or **J35689** into the connector (Figure 33). Pull back on the wire slightly, pry up the locking tang and then push the wire through the front of the connector. If the terminal will be reused, reshape the locking tang.

### Step 2: Connector Assembly and Terminal Insertion

Insert the wire through the seal and the connector body (Figure 35). Crimp the terminal to the stripped wire. Pull the wire and the terminal back through the connector body until it locks in place (Figure 36).

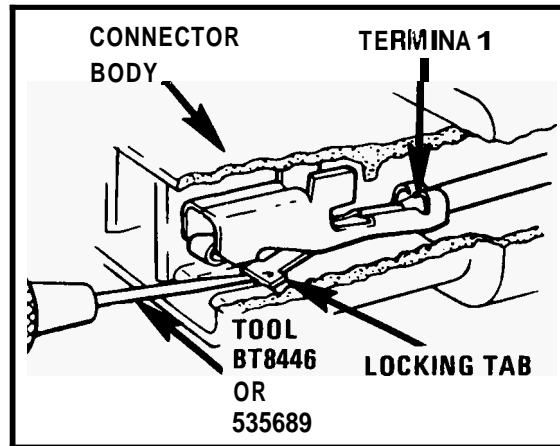

Figure 33 - Terminal Removal From Connector Body

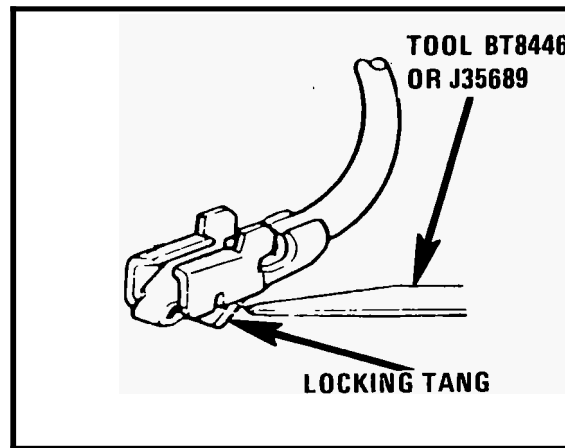

Figure 34 - Reforming The locking Tang

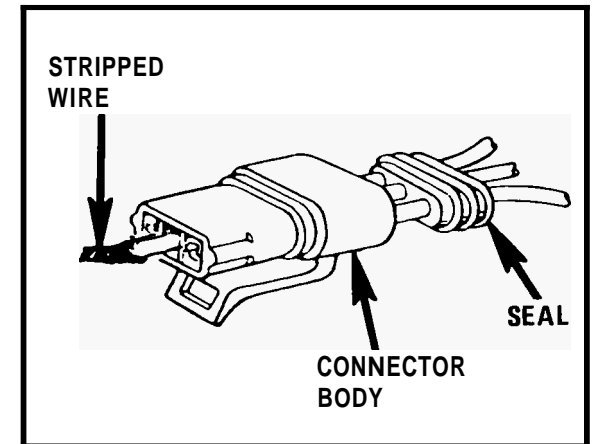

Figure 35 - Connector Reassembly

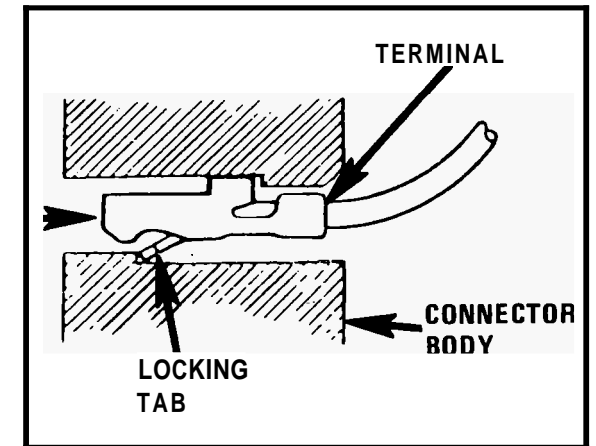
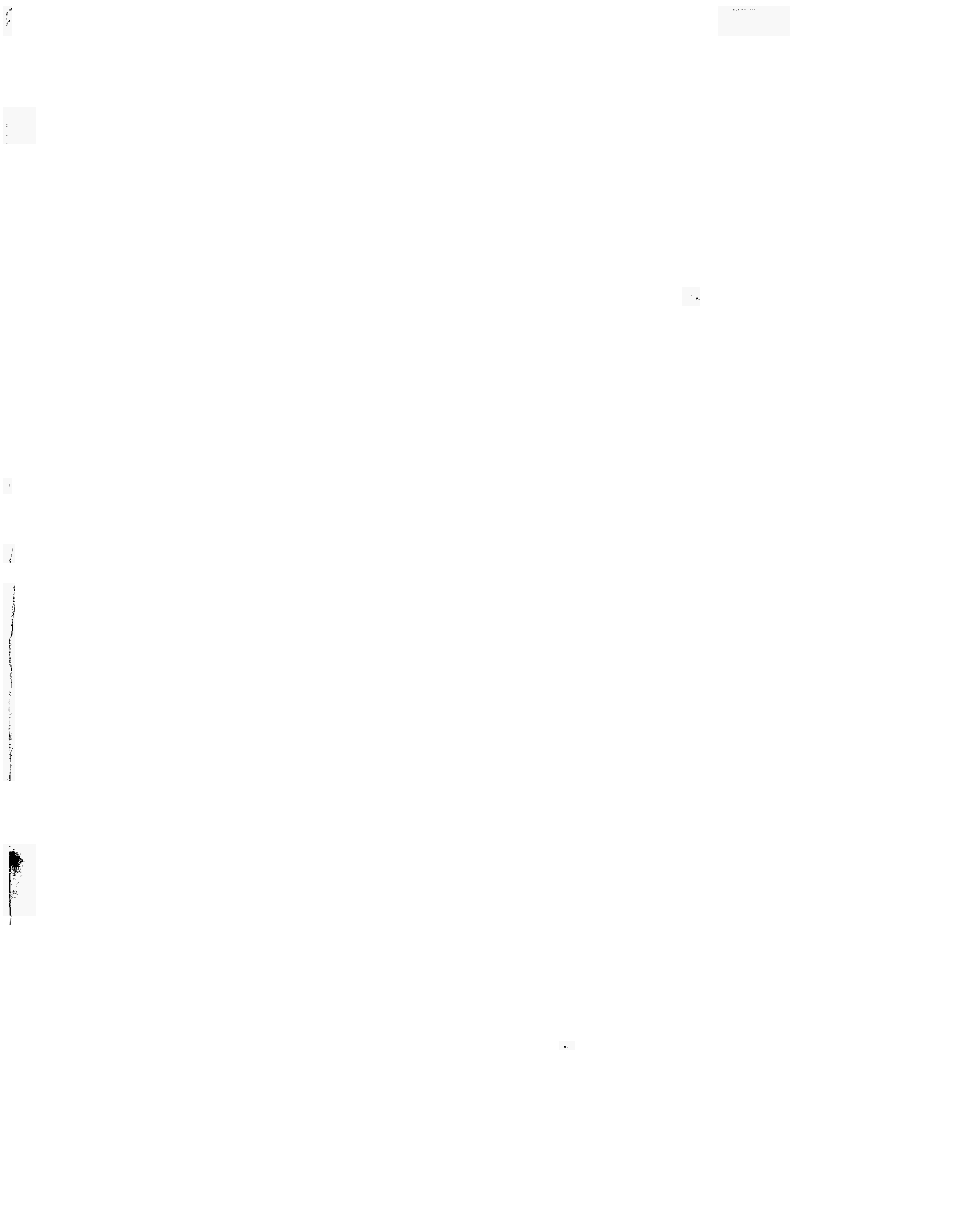

Figure 36 - Terminal Reinsertion



## SECTION 8A

# ELECTRICAL DIAGNOSIS

### REGAL

## Cell

- 1 Index
- 10 Power Distribution
- 11 Fuse Block Details
- 12 Light Switch Details
- 13 Accessory Panel Details
- 14 Ground Distribution
- 20 Engine: Computer Command Control (VINA)
- 21 Engine: Multiport Injection (VIN7)
- 22 Engine: Computer Command Control (VINY)
- 30 Starter and Charging System
- 31 Coolant Fans
- 32 Choke Heater
- 33 Vehicle Speed Sensor
- 34 Cruise Control
- 40 Horns
- 41 Brake Warning System
- 46 Power Master Brake System
- 60 Heater
- 61 Defoggers
- 62 Air Conditioning: System Check
- 63 Air Conditioning: Blower Controls (C60)
- 64 Air Conditioning: Compressor Controls (C60)
- 65 Air Conditioning: Air Delivery (C60)

## Cell

- 77 Warnings and Alarms: Chime
- 80 Instrument Panel: Indicators Cluster
- 82 Instrument Panel: Digital Cluster
- 90 Wiper/Washer
- 91 Wiper/Washer: Pulse
- 100 Headlights
- 101 Headlights with Sentinel
- 110 Exterior Lights
- 112 Back Up Lights
- 113 Cornering Lights
- 114 Interior Lights
- 117 Interior Lights Dimming
- 120 Power Windows
- 122 Sunroof
- 130 Power Door Locks
- 133 Theft Deterrent System
- 134 Trunk Release
- 140 Power Seats
- 150 Radio
- 151 Power Antenna
- 201 Component Location Views
- 202 Harness Connector Faces
- 203 Harness Routing Views

	Page		Page		Page
Accessory Panel Details .....	13-0	Computer Command Control		Marker.....	110-5
Air Conditioning		(V6VIN A) .....	20-0	<b>Park</b> .....	110-5
<b>Air</b> Delivery Controls		(V8VIN Y).....	22-0	Stop.....	110-0
C60. Manual .....	65-0	Multi-Port Fuel Injection (VIN 7) ..	21-0	Tail.....	110-8
Blower Controls		Fuse Block Details .....	11-0	Turn.....	110-0
C60. <b>Manual</b> .....	63-0	Ground Distribution.....	14-0	Lights (Interior)	
Compressor Controls		Harness Routing Views .....	203-0	Clock .....	114-2
C60. <b>Manual</b> .....	64-0	Heater .....	60-0	Courtesy .....	114-0
System Check .....	62-0	Horns.....	40-0	Dome .....	114-0
Alarms (Audible)		Indicators		Engine Compartment .....	114-2
Chime .....	77-0	Digital Cluster .....	82-0	Front Cigar Lighter .....	114-2
Antenna (Power).....	151-0	Brake .....	82-0	Glove <b>Box</b> .....	114-2
Brakes		Cruise.....	82-2	Reading .....	114-0
Power Master Brake System .....	46-0	Fasten Belts .....	82-1	Rear Quarter.....	114-2
Brake Warning System .....	41-0	High Beam .....	82-1	Trunk.....	114-2
Charging System		Oil/Check .....	82-3	Vanity .....	114-2
V6 VIN A and V8 VIN Y .....	30-0	Security System .....	82-2	Light Switch Details.....	12-0
Turbo VIN 7 .....	30-1	Service Engine Soon.....	82-2	Power Distribution .....	10-0
Choke Heater .....	32-0	Turn .....	82-1	Radio .....	150-0
Circuit Breaker Details		Water Temp.....	82-3	6 Speaker System .....	150-2
PWR/ACC Circuit Breaker... 10-1 & 11-8		Volts .....	82-3	Seats (Power)	
WDO Circuit Breaker.....	11-7	Instrument Panel		Three Motors .....	140-0
Connectors (Harness Connector Faces) 202-0		Digital Cluster .....	82-0	Starter .....	30-0
C100 Details .....	202-0	Indicators Cluster .....	80-0	V6 VIN A and V8 VIN Y .....	30-0
Junction Block (C453) Details .....	202-1	Interior Lights Dimming .....	117-0	Turbo VIN 7 .....	30-1
Component Location Views .....	201-0	Lights (Exterior)		sunroof .....	122-0
Coolant <b>Fans</b> .....	31-0	Back Up .....	112-0	Tailgate Release .....	134-0
Cruise Control .....	34-0	Coach.....	110-11	Theft Deterrent System .....	133-0
Defogger .....	61-0	Cornering .....	113-0	Trunk Release .....	134-0
Door Locks (Power).....	130-0	Front Marker .....	110-5	Vehicle Speed Sensor .....	33-0
Engine Control		Front Park.....	110-5	Windows (Power) .....	120-0
		Hazard.....	110-0	Tailgate .....	123-0
		Headlights .....	100-0	Wiper/Washer	
		With Twilight Sentinel .....	101-0	With Pulse .....	91-0
				Without Pulse.....	90-0



INDEX

**BLANK**

# POWER DISTRIBUTION

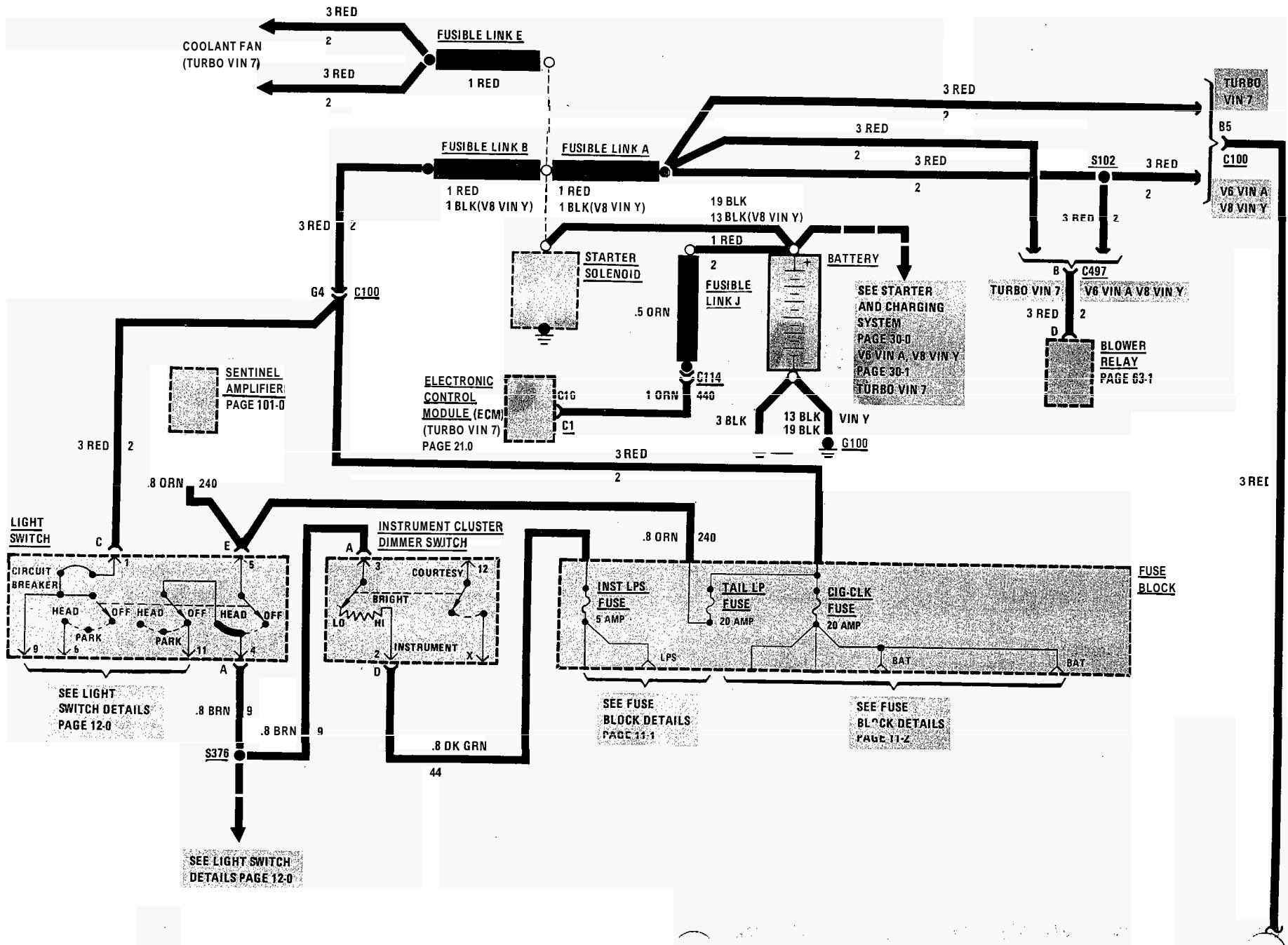



**CIRCUIT OPERATION**

Electrical power for the car is provided by the Generator when the engine is running. The schematic diagram shows how each circuit gets its power. For more detail about the generator, and connections to the Battery and Starter, see Starter and Charging System.

The car's Power Distribution system consists of Fusible Links, Fuses, Circuit Breakers, the Light Switch, and the Ignition Switch. Fusible Links are short pieces of wire several times smaller than the circuit wire to which they supply power. They are covered with a special high-temperature insulation. When conduction too high a current, they will melt and stop current flow. They are designed to protect the car's electrical system from electrical shorts that are not protected by the circuit breakers and fuses. See Fuse Block Details and Light Switch Details for complete wiring to first component in each circuit.

The Ignition Switch has *six* positions, five of which have detents. The BULB TEST position is after the RUN position and just before the START position. BULB TEST does not have a detent.

As shown in the schematic, circuits which are supplied from the Ignition Switch are ON (hot) for different switch positions. The hot bar at the top of each schematic states when the fuse is hot according to the position of the Ignition Switch.

**COMPONENT LOCATION**

Page-Figure

Blower Relay	RH rear of engine compartment, on A/C accumulator	201-19-B
Convenience Center	Behind I/P, left of radio	201-15-A
Electronic Control Module (ECM)	RH shroud, near lower access hole	201-17-B
Fuse Block	Under LH side of I/P	201-12-A
Fusible Link A (VIN 7)	Engine harness, near starter solenoid	201- 6-B
Fusible Link A (VIN A)	Engine harness, near starter solenoid	201- 0-A
Fusible Link A (VIN Y)	Engine harness, near starter solenoid	201- 5-A
Fusible Link B (VIN 7)	Engine harness, near starter solenoid	201- 6-B
Fusible Link B (VIN A)	Engine harness, near starter solenoid	201- 0-A
Fusible Link B (VIN Y)	Engine harness, near starter solenoid	201- 5-A
Fusible Link E (VIN 7)	RH side of engine, near starter solenoid	201- 6-B
Fusible Link J (VIN 7)	RH front of engine compartment, behind battery	201- 5-F
Ignition Switch	Base of steering column	201-13-A
In-Line Fuse A	Taped to I/P harness, behind RH side of cluster	201-11-A
In-Line Fuse B	Taped to I/P harness, behind RH side of cluster	201-11-A
Power Master Brake Relay	LH front of dash, below brake master cylinder	201- 9-A
Sentinel Amplifier	Behind I/P, right of radio	201-13-D
Starter Solenoid (VIN 7)	Lower RH side of engine	201- 6-B
Starter Solenoid (VIN A)	Lower RH side of engine	201- 0-A
Starter Solenoid (VIN Y)	Lower LH side of engine	201- 5-A
Theft Deterrent Controller	Behind I/P, near LH shroud	201-11-A
Theft Deterrent Relay	Behind I/P, left of steering column	201-11-A
C100 (45 cavities)	LH rear of engine compartment	201- 9-B
C114 (VIN 7) (1 cavity)	RH front of engine compartment, behind battery	201- 5-F
C497 (VIN 7) (4 cavities)	RH rear of engine compartment, near blower motor	201- 7-C
C497 (VIN A) (4 cavities)	RH rear of engine compartment, below valve cover	201- 2-A
C497 (VIN Y) (4 cavities)	Behind RH side of I/P, right of radio	201-16-B
C815 (7 cavities)	Behind I/P, on RH side of steering column	201-13-A
G100 (VIN 7)	RH front of engine, on cylinder head	201- 5-E
G100 (VIN A)	Front of engine, below generator	201- 0-B
G100 (VIN Y)	On LH cylinder head, behind generator	201- 3-B

**BLANK**



# FUSE BLOCK DETAILS; INST LPS FUSE

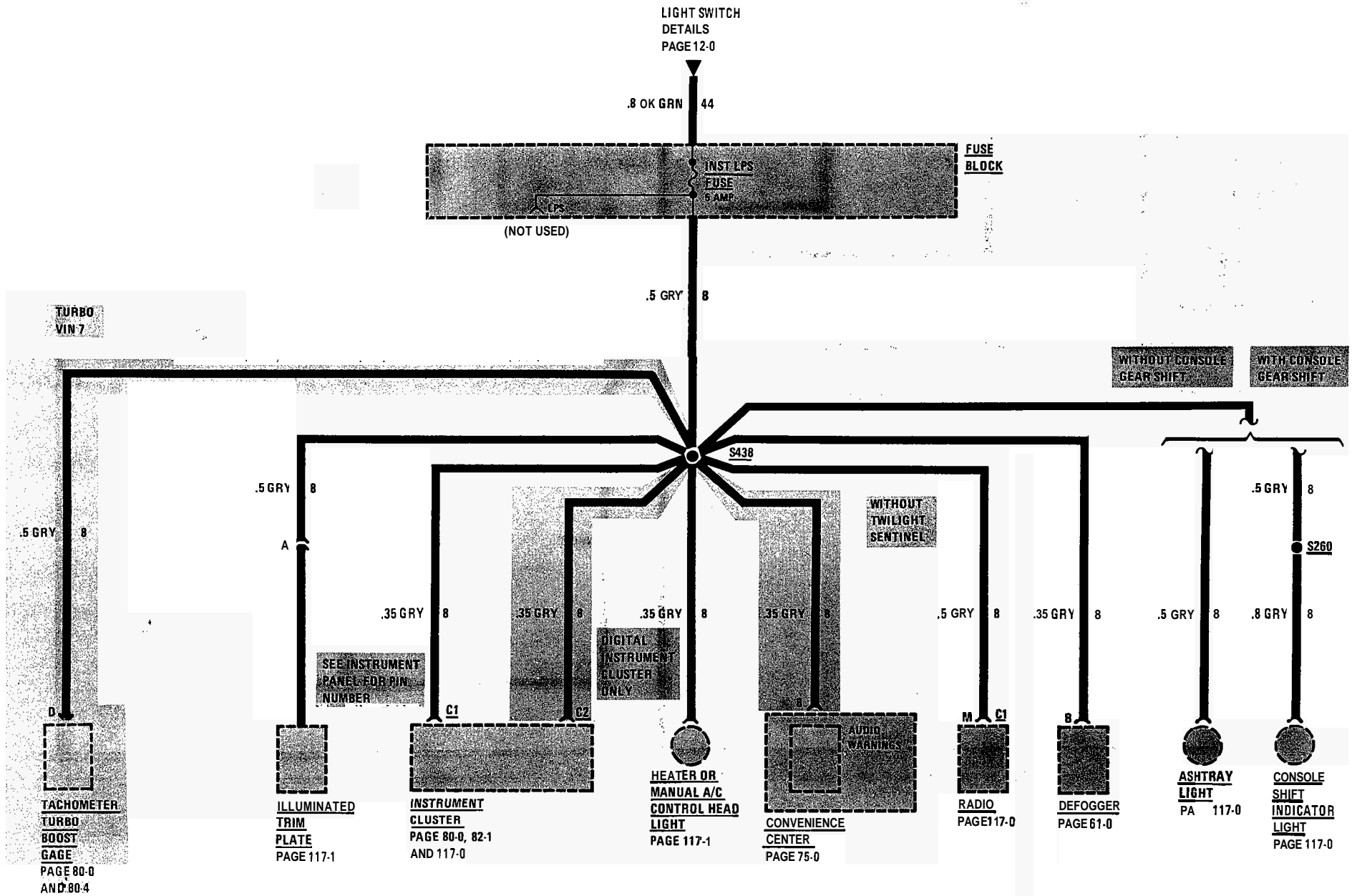







FUSE BLOCK DETAILS: ST BLT/ACC FUSE ≈ TURN B/U FUSE

HOT IN RUN, BULB TEST OR START

