

SECTION 6J

TURBOCHARGER

RPO LT3, LC2

VIN CODE M, 7

CONTENTS

GENERAL DESCRIPTION

Turbocharger Introduction	6J-1
Turbocharger Definitions	6J-2
Turbocharger Operation	6J-4
Turbocharger Performance	6J-4
Intercooler Operation	6J-4
Turbocharger Oil Supply	6J-4
Turbocharger Maintenance	6J-5

SYSTEM TROUBLESHOOTING AND DIAGNOSIS

Troubleshooting Procedures	6J-5
Noise and Air Leak Check	6J-7
Turbocharger Unit Inspection	6J-8

FAILURE ANALYSIS AND CORRECTIVE PROCEDURES	6J-9
Major Causes of Turbocharger Failures	6J-9

ON-CAR SERVICE

2.0 LITER-VIN M

Turbocharger	6J-13
Wastegate Actuator	6J-14
Intake Manifold	6J-15

Exhaust Manifold	6J-16
Turbocharger Oil Pipe and Hose Routing	6J-16
Wastegate/Boost Pressure Test Procedure	6J-16
Specifications	6J-17
3.8 LITER-VIN 7	
Turbocharger	6J-18
Wastegate Actuator	6J-18
Intake Manifold	6J-18
Exhaust Manifold	6J-19
Vacuum Hose & Line Routings	6J-21
Oil Feed & Drain Pipes	6J-21
Control Assembly & Wastegate Solenoid	6J-21
Wastegate/Boost Pressure Test Procedure	6J-21
Road Test	6J-22
Turbocharger Internal Inspection Procedure	6J-22
Specifications	6J-24

GENERAL DESCRIPTION

TURBOCHARGER INTRODUCTION

See Figures 1 thru 9

The turbocharger is basically an air compressor or air pump. It consists of a turbine or hot wheel, a shaft, a compressor or cold wheel, a turbine housing, a compressor housing, and a center housing which contains bearings, a turbine seal assembly and a compressor seal assembly.

Before entering into a discussion concerning the turbocharged engine system, we should review the basic characteristics of both the internal combustion engine and the turbocharger.

The internal combustion engine is classified as an air breathing machine. This means that the amount of power that can be obtained from a given displacement engine is determined by the amount of air that it breathes in a certain period of time and not by the amount of fuel that is used. This is because the fuel that is burned requires air with which it can mix to complete the combustion cycle. Once the air/fuel ratio reaches a certain point, the addition of more fuel will not produce more power, only black smoke. The more dense the smoke, the more the engine is being overfueled. Therefore, increasing the fuel delivery

beyond the air/fuel ratio limit results only in excessive fuel consumption.

Turbochargers are installed on an engine to put more and denser air into the engine combustion chambers. Because of the increased volume and weight of compressed air more fuel can be scheduled to produce more horsepower from a given size engine. The turbocharged version of an engine will also maintain a higher level of power output than the non-turbocharged version when operated at altitudes above sea level.

TURBOCHARGER DEFINITIONS

Turbine - The rotating wheel driven by exhaust gasses also called hot wheel.

Compressor - The rotating wheel driven by the center shaft which is turned by the turbine. Also called the cold wheel.

Center Shaft - The shaft that connects the turbine to the compressor.

CHRA - Center Housing Rotating Assembly consists of: turbine, compressor, center housing, shaft, bearings and seals.

Wastegate - A valve that allows some of the exhaust gas to bypass the turbine wheel. This is done to limit boost.

6J-2 TURBOCHARGER

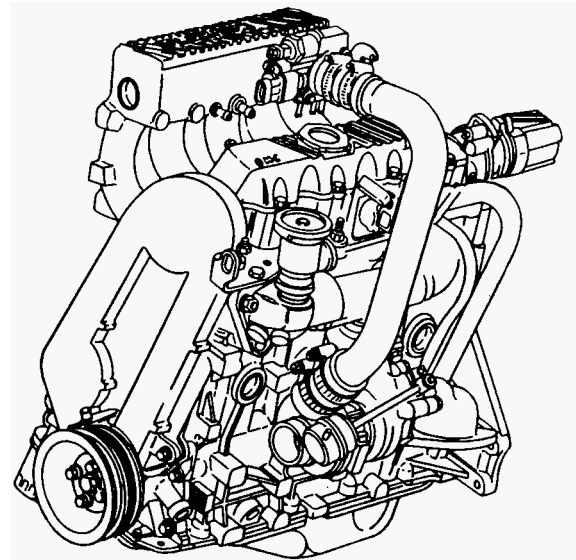
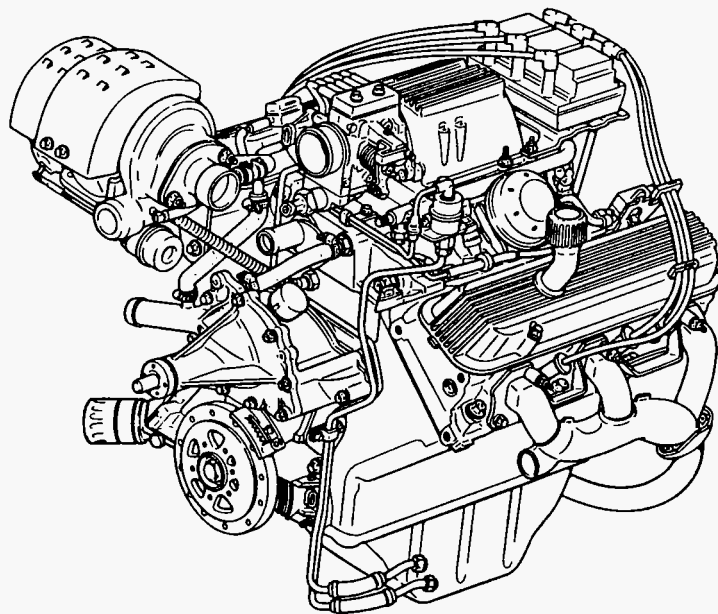

H40000-6J-GJ

Figure 1 2.0 VIN M & 3.8 VIN 7 Engines

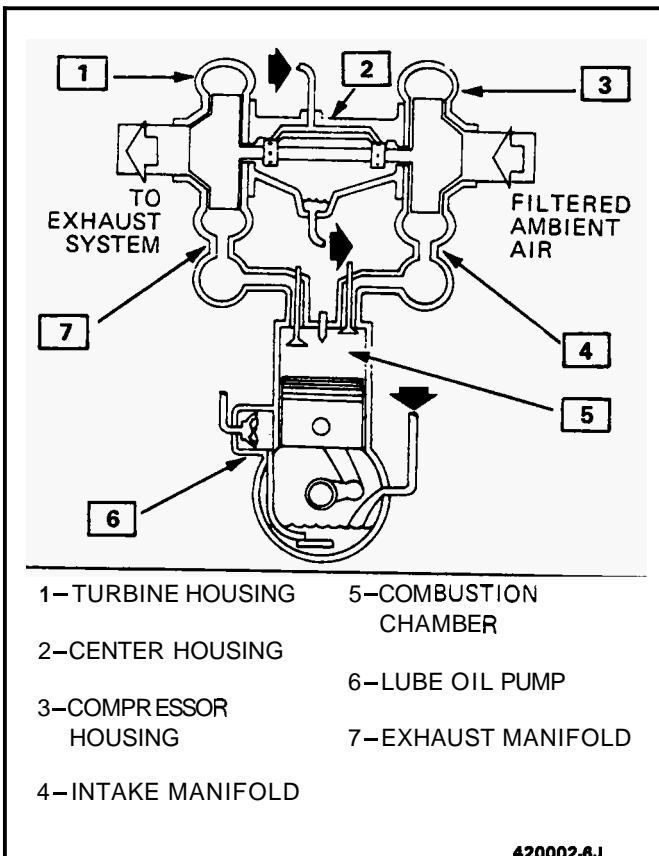

Figure 2 Turbocharger Operation

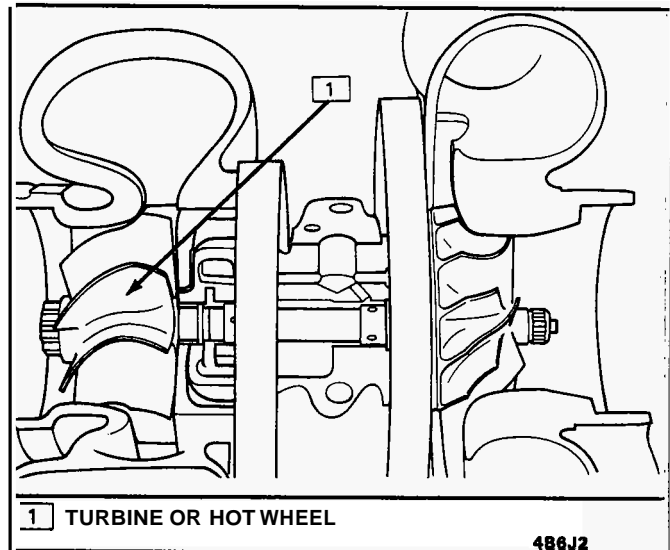

Figure 3

Wastegate Actuator - A pressure sensitive servo that controls the wastegate.

Boost - Inlet manifold pressure higher than one atmosphere. (Positive Pressure.)

Coking - A condition that occurs when oil oxidizes on hot turbocharger interior surfaces.

Intercooler - A heat exchanger used to cool pressurized inlet air.

Wastegate Solenoid Valve - A pulse width modulated solenoid activated by the **ECM** that controls pressure to the wastegate actuator.

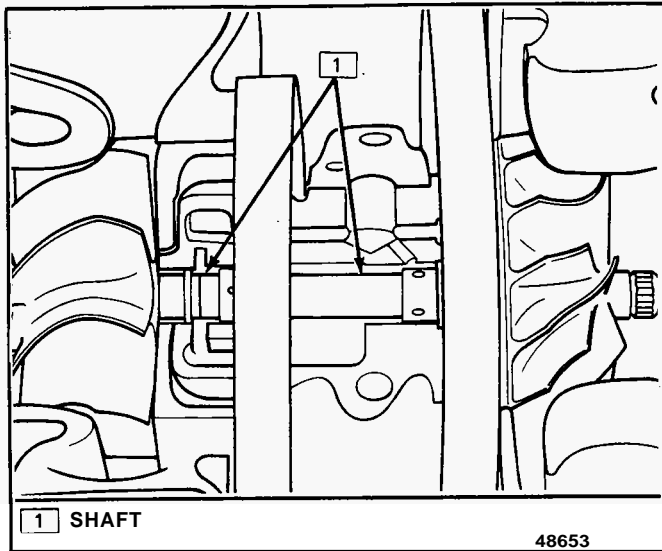

Figure 4

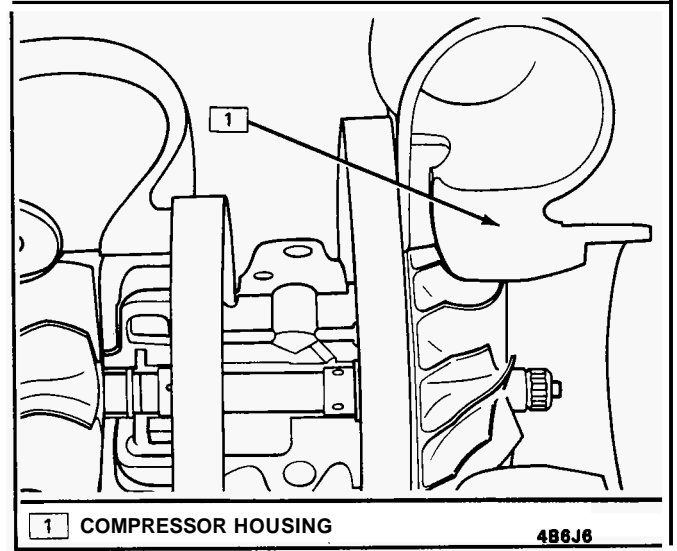

Figure 7

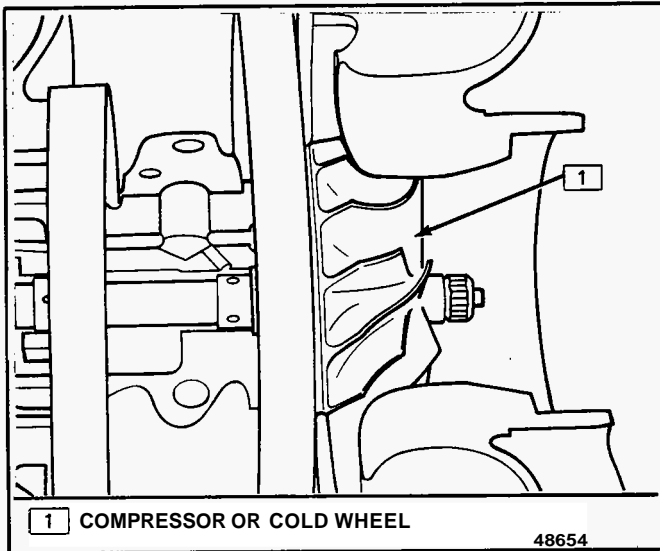

Figure 5

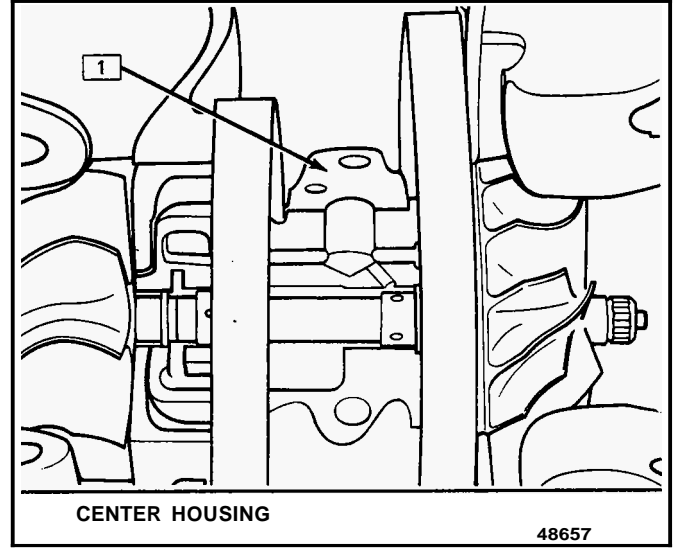

Figure 8

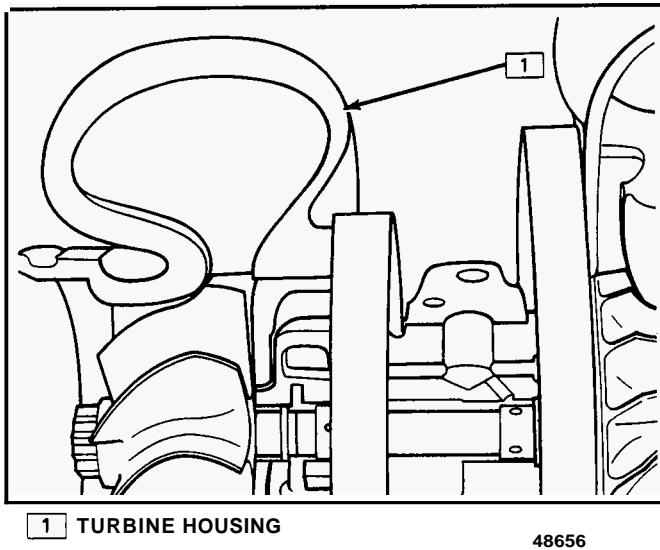

Figure 6

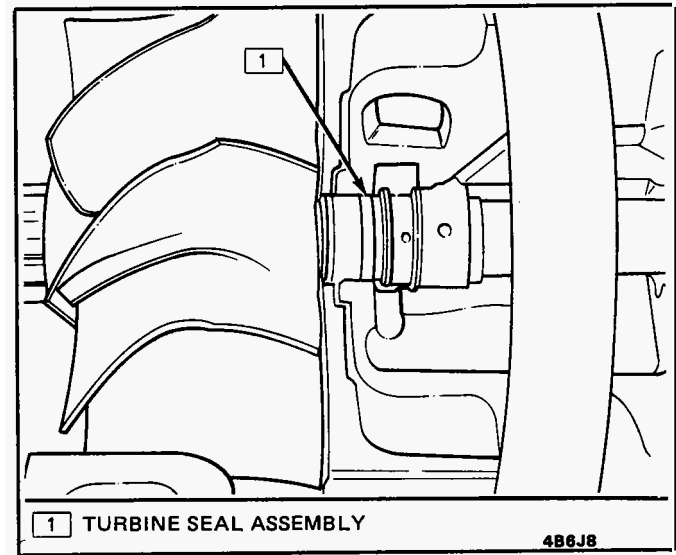

Figure 9

6J-4 TURBOCHARGER

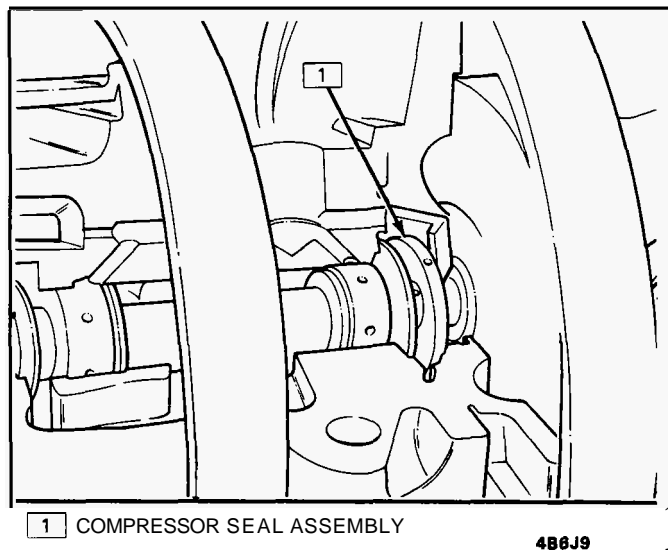

Figure 10

TURBOCHARGER OPERATION

A turbocharger is an air pump designed to operate on the normally wasted energy in engine exhaust gas. These gases drive the turbine (hot) wheel and shaft which is coupled to a compressor (cold) wheel which when rotating provides a high volume of air to the engine combustion chambers.

The turbocharger, although precision built, is basically a very simple but durable machine. It does, however, require maintenance and care as does any other piece of working machinery. A positive flow of clean lubricating oil is most critical.

The heat energy and pressure in the engine exhaust gas are utilized to drive the turbine wheel. The speed of the rotating assembly and output of the compressor wheel are controlled by the design and sizing of the turbine wheel and turbine housing and the wastegate assembly.

TURBOCHARGER PERFORMANCE

A turbocharger is used to increase power on a demand basis. As load on the engine is increased and the throttle is opened, more air-fuel mixture flows into the combustion chambers. As this increased flow is burned a larger volume of higher energy exhaust gas enters the engine exhaust system and is directed through the turbocharger turbine housing. Some of this energy is used to increase the speed of the turbine wheel. The turbine wheel is connected by a shaft to the compressor wheel. The increased speed of the compressor wheel allows it to compress the air it receives and deliver it to the intake manifold. The resulting higher pressure in the intake manifold allows a denser charge to enter the combustion chambers. The denser charge can develop more power during the combustion cycle.

The intake manifold pressure (boost) is controlled to a correct maximum value by an exhaust bypass valve (wastegate). The valve allows a portion of the exhaust gas to bypass the turbine wheel, thus maintaining a desired boost level. The wastegate is operated by a spring loaded diaphragm (actuator assembly) that

operates in response to boost pressure controlled by the wastegate solenoid to control maximum boost level.

(The wastegate solenoid is ECM controlled, for diagnosis and service procedures, see Section 6E.)

Some naturally-aspirated engines increase power by larger displacements which allows them to increase air-fuel consumption. Turbocharging allows increased air-fuel consumption and power without increasing displacement. A turbocharged engine is a finely tuned assembly which can adapt to increases in air-fuel consumption and the balanced increases in exhaust which occur under boost conditions. Any alteration to the air intake or exhaust system which upsets the air flow balance may result in serious damage to the turbocharged engine.

There are quite a number of benefits to be gained by turbocharging. Combustion of the fuel is more complete, cleaner, and takes place within the engine cylinders where its work is accomplished, because the turbocharger delivers an abundance of compressed air to the engine. The positive air pressure head (above atmospheric pressure) that is maintained in the engine intake manifold benefits the engine in several ways. During engine valve overlap (before the intake stroke starts), clean air is pushed across the combustion chamber scavenging remaining burned gases, cooling the cylinder heads, pistons, valves and the exhaust gas. The cleaner burning of the fuel plus the engine cooling which results helps to extend engine life.

INTERCOOLER OPERATION

The 3.8L turbocharged engine uses an air to air intercooler to lower the inlet air temperature and increase inlet air density. The cooler, denser inlet air allows a more dense air/fuel charge to enter the combustion chamber and increases power output by approximately 15%.

As inlet air is compressed, its temperature increases. This heated, pressurized air is then routed thru the core of the intercooler. The intercooler is very similar in construction to a traditional radiator. Outside air passes thru the intercooler to lower the temperature of the inlet air in the core of the intercooler.

To increase the efficiency of the intercooler at low vehicle speeds, a crankshaft mounted fan pulls air thru the intercooler.

TURBOCHARGER OIL SUPPLY

An adequate supply of clean engine oil is essential for cooling and lubrication to maintain the turbocharger bearing system. The rotating assembly (turbine wheel, connecting shaft, and compressor wheel) can attain speeds of 130,000 to 140,000 RPM during boost. Interruption or contamination of the oil supply to the bearings (in the center housing) which support the rotating assembly can result in major turbocharger damage.

NOTICE: Any time a basic engine bearing (main bearing, connecting rod bearing, camshaft bearing) has been damaged in a turbocharged engine, the oil and oil filter should be changed as a part of the

repair procedure. In addition, the turbocharger should be flushed with clean engine oil to reduce the possibility of contamination.

Any time a turbocharger assembly is being replaced, the oil and oil filter should be changed as a part of the repair procedure.

TURBOCHARGER MAINTENANCE

Good maintenance practices should be observed, particularly regarding air and oil filtration, to maintain the service life and performance of a turbocharger. Years of experience has shown that the largest percentage of turbocharger failures are caused by oil lag, restriction or lack of oil flow and dirt in the oil. The second largest percentage is caused by foreign objects entering the compressor and/or turbine wheels.

1. Dust or sand entering the turbocharger compressor housing from a leaky air inlet system can seriously erode the compressor wheel blades and will result in the deterioration of turbocharger and engine performance. The wearing away of the blades, if uneven, can induce a shaft motion which will pound out and eventually fail the turbocharger shaft bearings. Ingestion of sand or dust will also cause excessive wear on engine parts, such as pistons, rings, valves, etc. Entrance of large or heavy objects, bolts, nuts, rocks, tools, etc., will completely destroy the turbocharger and in many instances cause severe damage to the engine.
2. Plugged or restricted air cleaner systems, resulting from poor maintenance procedures, will reduce air pressure and volume at the compressor air inlet and cause the turbocharger to lose performance. The restricted air cleaner and the resultant air pressure drop between cleaner and turbocharger can, during engine idle periods, cause oil pullover at the compressor end of the turbocharger. This would be a compressor end oil seal leak without a failure of seal parts. Proper servicing of the air cleaner system can prevent and correct the above problems.
3. Dirt or foreign material, when introduced into the turbocharger bearing system by the lube oil, creates wear primarily on the center housing bearing bore surfaces. Contaminants imbed in the bearing surfaces and act as an abrasive cutting tool and eventually wear through. When bearing and bore wear becomes excessive, the shaft hub and either or both wheels will start to rub on the housings, causing the rotating assembly to turn slower. Turbocharger and engine performance will rapidly deteriorate from this point, and such indications as engine power loss, excessive smoke, excessive noise and the appearance of oil at either or both ends of the turbocharger could be noted. Contaminated and dirty oil is prevented when the lube oil system is properly serviced.
4. A turbocharger should never be operated under engine load conditions with less than 30 psi oil pressure. A turbocharger is much more sensitive to a limited oil supply than an engine, due to the

high rotational speed of the shaft and the relatively small area of the bearing surfaces.

Oil pressure and flow lag during engine starting can have detrimental effects on the turbocharger bearings. During normal engine starting, this should not be a problem. There are, of course, abnormal starting conditions. Oil lag conditions will most often occur during the first engine start after engine oil and filter change when the lubricating oil system is empty. Similar conditions can also exist if an engine has not been operated for a prolonged period of time because engine lube systems have a tendency to bleed down. Before allowing the engine to start, the engine should be cranked over until a steady oil pressure reading is observed, priming the lubricating system. The same starting procedure should be followed when starting an engine in cold weather as the engine oil can be congealed and take a longer period of time to flow. Turbocharger bearing damage can occur if the oil delay is in excess of 30 seconds, and much sooner if the engine is allowed to accelerate much beyond low idle rpm.

SYSTEM TROUBLESHOOTING AND DIAGNOSIS

First it should be emphasized that a turbocharger does not basically change the operating characteristics of an engine. A turbocharger is not a power source within itself. The turbocharger's only function is to supply a greater volume of compressed air to the engine so that more fuel can be burned to produce more power. It can function only as dictated by the flow, pressure and temperature in the engine exhaust gas.

A turbocharger cannot correct or overcome such things as malfunctions or deficiencies in the engine fuel system, timing, plugged air cleaners, etc. Therefore, if a turbocharged engine system has malfunctioned and the turbocharger has been examined and determined to be operational, proceed with trouble shooting as though the engine were non-turbocharged. Simply replacing a good turbocharger with another will not correct engine deficiencies.

All too frequently, serviceable turbochargers are removed from engines before the cause of malfunction has been determined. Always inspect and assess turbocharger condition before removal from the engine.

Inspect

See Figures 10 thru 13

1. Remove inlet and exhaust tubing from the turbocharger.
2. Both wheels for blade damage caused by foreign material. The compressor wheel can be inspected by looking through the compressor housing inlet opening while holding throttle blade open. A light is necessary when examining the turbine wheel blade tips, as they are positioned inside the turbine housing and you have to look between the

6J-6 TURBOCHARGER

turbine wheel blades from the exhaust outlet end of the turbine housing.

3. The outer blade tip edges on both wheels, adjacent to their respective housing bores, and check for wheel rub.
4. Rotate the shaft wheel assembly by hand and feel for drag or binding conditions. Push shaft to side and rotate to feel for rub. It should turn smoothly.
5. Lift both ends of the shaft up and down at the same time and feel for excessive journal bearing clearance. If clearance is normal, very little shaft movement will be detected. If a unit having normal bearing clearance of .003 to .006 is rocked up and down from one end only, the movement at end of shaft could be dial indicated at .015 to .020. Actual shaft end play is easily indicated without removing the turbocharger from the engine.
6. If the shaft assembly rotates freely and no wheel damage, binding or rub has been noted, it can be assumed that the turbocharger is serviceable.

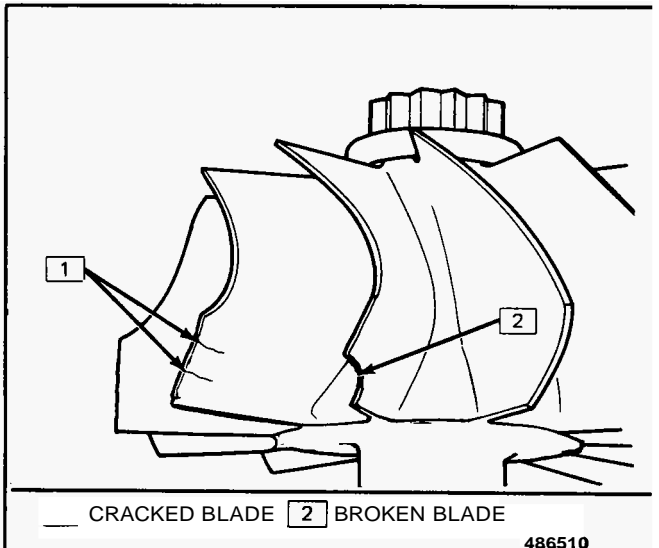

Figure 11

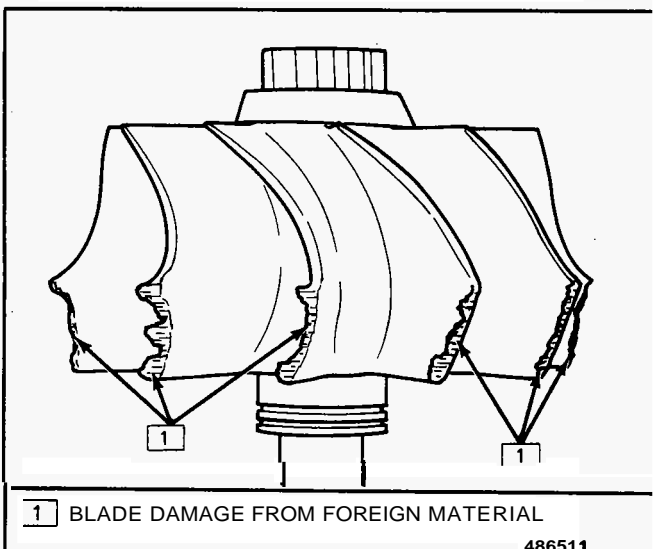

Figure 12

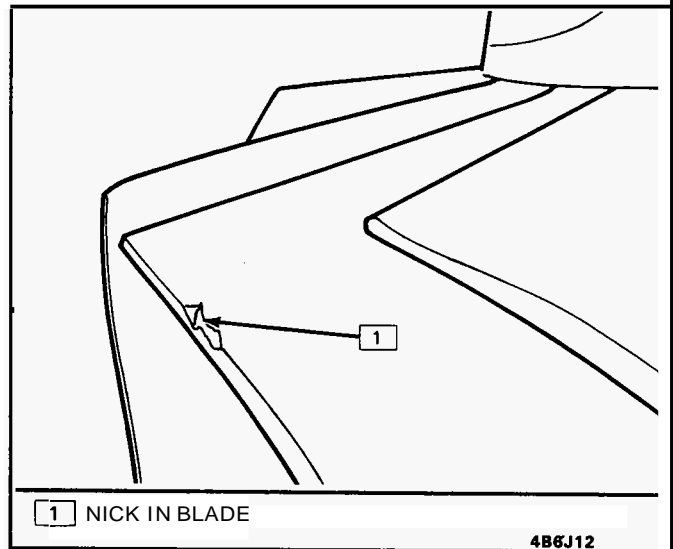

Figure 13

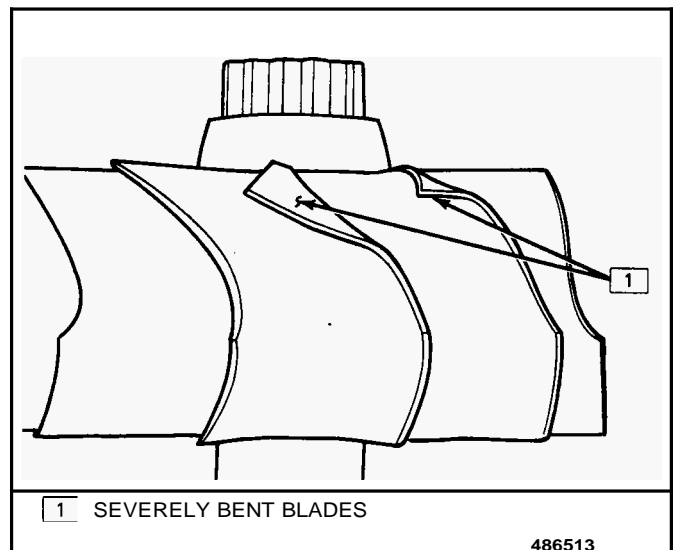

Figure 14

TROUBLESHOOTING PROCEDURES

See Figures 15 and 16

! Important

To acquire confidence, ability and feel for accomplishing a turbocharger inspection, examine a new turbocharger as outlined. Compare inspection results between the new and used turbocharger.

Turbocharger actual shaft end play and journal bearing radial clearances can be checked as per instructions in the applicable turbocharger service manual.

CAUTION: Operation of the turbocharger without all normally installed inlet ducts and filters connected can result in personal injury and equipment damage from foreign objects entering the turbocharger.

Each turbocharged engine system has its own distinctive sound or noise level when operating. In

many cases, malfunctions can be detected when this noise level changes. if the noise level changes to a higher pitch it can indicate an air leak between air cleaner and engine or a gas leak in the exhaust system between turbocharger and engine. Noise level cycling from one level to another can indicate a plugged air cleaner, restriction in front of the turbocharger air inlet or heavy dirt build up in the compressor housing and on the compressor wheel. A sudden reduction in noise level with resultant black or blue smoke and excessive oil leakage indicates a complete failure.

NOISE AND AIR LEAK CHECK

With the engine running, check the turbocharger for uneven noise and vibration. This can indicate malfunction in the shaft wheel assembly. If suspicious conditions are noted, shut down the engine immediately to protect the turbocharger and engine from further damage.

Examine the turbocharger as per recommended inspection procedures. If any damage is evident, the turbocharger will have to be removed, cleaned and repaired or replaced as necessary.

If the turbocharger is assumed to be functional proceed with a check of the air system as follows:

 **inspect**

Engine **not** running:

1. Air cleaner for a restricted condition.
2. All hose clamps for tightness.
3. Intake manifold gasket and seals.

4. All hoses for cracks or deterioration.

With engine running at idle:

1. Air tube and connections between air cleaner and turbocharger can be checked by lightly spraying with starting fluid. Leaks will be indicated by an increase in engine speed because the starting fluid will be pulled through the compressor wheel and into the engine.
2. Air leaks between turbocharger and engine can be checked by feel and by an application of a light weight oil or soap suds on crossover tube, connections and hoses. Look for bubbles.

Exhaust gas leakage between engine block and inlet to turbocharger will also create a noise level change and reduced turbocharger performance. Check exhaust system as follows:

 **inspect**

1. Manifold gaskets for leakage.
2. Manifold retaining bolts for tightness.
3. Manifold for cracks or porosity.
4. Turbocharger inlet gasket for leaks.
5. Turbocharger inlet flange bolts for tightness.

Exhaust gas leakage is detected by heat discoloration in the area of the leak.

TURBOCHARGER TROUBLESHOOTING									
PROBLEM									
Engine lacks power	Black exhaust smoke	Excessive engine oil consumption	Blue exhaust smoke	Turbocharger noisy	Cyclic sound from turbocharger	Oil leak from turbocharger seal	Oil leak from turbine seal		
CAUSE									
REMEDY									
								Clogged air filter element	Replace element
▲	▲	▲	▲	▲	▲			Obstructed air intake duct to turbo compressor	Remove obstruction or replace damaged parts as required
▲	▲			▲				Obstructed air outlet duct from compressor to intake manifold	Remove obstruction or replace damaged parts as required
▲	▲			▲				Obstructed intake manifold	Refer to engine mechanical section & remove obstruction
				▲				Air leak in duct from air cleaner to compressor	Correct leak by replacing seals or tightening fasteners as required
▲	▲	▲	▲	▲				Air leak in duct from compressor to intake manifold	Correct leak by replacing seals or tightening fasteners as required
▲	▲	▲	▲	▲				Air leak at intake manifold to engine joint	Refer to engine mechanical section & replace gaskets or tighten fasteners as required
▲	▲	▲	▲	▲			▲	Obstruction in exhaust manifold	Refer to engine mechanical section & remove obstruction
▲	▲						▲	Obstruction in exhaust system	Remove obstruction or replace faulty components as required
▲	▲						▲	Gas leak in exhaust manifold to engine joint	Refer to engine mechanical section & replace gaskets or tighten fasteners as required
▲	▲			▲			▲	Gas leak in turbine inlet to exhaust manifold joint	Replace gasket or tighten fasteners as required
				▲				Gas leak in ducting after the turbine outlet	Refer to engine mechanical section & repair leak
		▲	▲			▲	▲	Obstructed turbocharger oil drain line	Remove obstruction or replace line as required
		▲	▲			▲	▲	Obstructed engine crankcase ventilation	Refer to engine mechanical section, clear obstruction
		▲	▲			▲	▲	Turbocharger center housing sludged or coked	Change engine oil & oil filter, overhaul or replace turbo as required
▲	▲							Engine camshaft timing incorrect	Refer to engine mechanical section
▲	▲	▲	▲			▲	▲	Worn engine piston rings or liners (blowby)	Refer to engine mechanical section
▲	▲	▲	▲			▲	▲	Internal engine problem (valves, pistons)	Refer to engine mechanical section.
▲	▲	▲	▲	▲	▲	▲	▲	Dirt caked on compressor wheel and/or diffuser vanes	Clean using a Non-Caustic cleaner & Soft Brush. Find & correct source of unfiltered air & change engine oil & oil filter
▲	▲	▲	▲	▲	▲	▲	▲	Damaged turbocharger	Analyze failed turbocharger, find & correct cause of failure, overhaul or replace turbocharger as required

Figure 15

6J-8 TURBOCHARGER

APPEARANCE OF BEARING												BEARING TROUBLESHOOTING	
Slight wear or scratches												CONDITION	PROBABLE CAUSE
Moderate to heavy grooving on O.D. only													
Extruded, or pounded on O.D. & I.D.													
Smooth undersized O.D.													
Cracked or broken													
Deep groove around center of O.D.													
Oil holes fully or partially closed													
Polished looking O.D.													
I.D. Polished & worn oversize													
Melted (aluminum bearing)													
●												Normal use	Acceptable operating & maintenance procedures
	●											Contaminated oil (dirt in oil)	Engine oil & oil filter(s) not changed frequently enough, unfiltered air entering engine intake, malfunction in prelube valve or oil filter bypass valve
		●			●							severely contaminated (dirty oil)	
			●		●		●					Pounded by eccentric shaft motion	Foreign object damage, coked or loose housing, excessive bearing clearance due to lube problem
				●					●			Center housing bearing bores, rough finish	Incorrect cleaning of ctr. hsg. during overhaul of turbo. (wrong chemicals, bores sand or bead blasted)
					●							Metal or large particle oil contamination	Severe engine wear. i.e., bearing damage, camshaft or lifter wear, broken piston
							●				●	Lack of lube, oil lag, insufficient lube	Low oil level, high speed shutdowns, lube system failure, turbo plugged
								●				Coking	Hot shutdowns, engine overfueled, restricted or leaking air intake
			●						●	●		Fine particles in oil (contaminated oil)	See contaminated oil
										●		Rough bearing journals on shaft	Bearing journals not protected from sand or bead blast cleaning during overhaul

486J15

Figure 16

TURBOCHARGER UNIT INSPECTION

CAUTION: Operation of the turbocharger without all ducts and filters installed can result in personal injury or foreign objects damaging the wheel blades.

Each turbocharger has its own distinctive sound or noise level when operating. In many cases malfunctions can be detected when this noise level changes. If the sound of the turbo cycles up and down in pitch, check for an inlet air restriction or heavy dirt build up in the compressor housing and on the compressor wheel. If the noise level is a high pitch or whistling, look for an inlet air or exhaust gas leak. See "Noise and Air Leak Check".

With the engine shut off and the turbo stopped turning completely, make a visual inspection of the turbocharger and components.



inspect

1. For loose ducting connections from the air cleaner to the turbo.
2. The cross-over duct from: the turbocharger to the intercooler, the intercooler to the throttle body. A loose duct can cause low power, noise, and oil loss through the compressor seals.
3. The wheels of the turbo for impact damage from foreign objects from engine or ducting.
4. For evidence of wheel contact against the housing walls. This would indicate internal bearing failure from loss of oil, contaminated oil, or imbalance.
5. The shaft for free rotation. Push inward on one of the shaft wheels while you turn it by hand and feel for any rubbing or binding, do the same on the other side. The wheels should turn freely without contacting housings, backplate or shroud. Stiffness could indicate the presence of sludged oil or coking from overheating.
6. The exhaust manifold and crossover pipe for loose connections and cracks.
7. Oil drain line for restrictions. Any restriction can cause severe oil loss through the turbo seals. There may also be traces of burned oil on the turbine housing exterior.

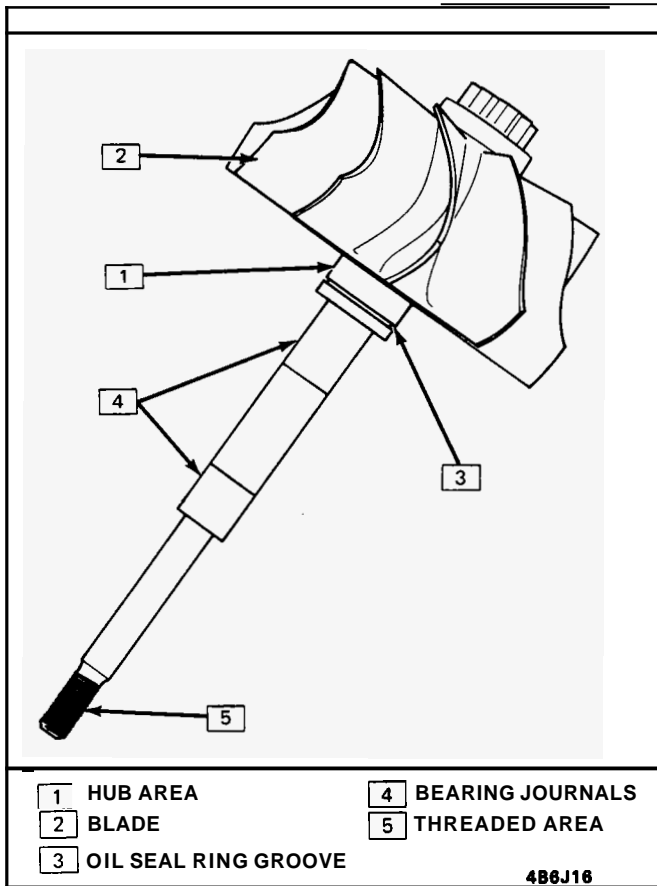

Figure 17

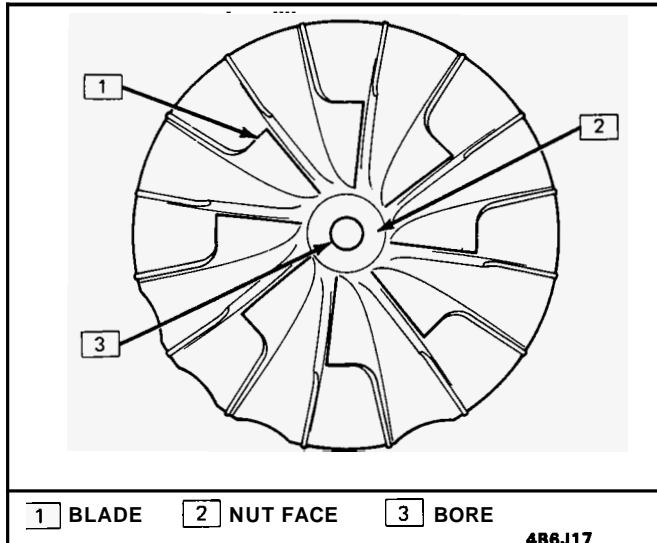

Figure 18

FAILURE ANALYSIS AND CORRECTIVE PROCEDURES

See Figures 17 thru 32

The importance of determining the exact cause of a turbocharger failure cannot be overemphasized. This determination should be made at the time of failure and should in all cases be corrected before a replacement turbocharger is installed.

Often, when a failed turbocharger is replaced with little or no thought given to the cause of the failure, there is a recurrence of the failure, resulting in

extra down time and expense. The initial and follow-on failure could also be of a type that could result in costly engine damage. The majority of turbocharger failures are found to be due to poor operating procedures, lack of, or improper preventive maintenance, or incorrect repair practices.

Although turbocharger durability and performance have greatly improved over the past few years, operational and environmental situations still exist that can result in turbocharger failure.

MAJOR CAUSES OF TURBOCHARGER FAILURE

There are many and varied causes of turbocharger failures. They can be grouped into four major categories:

- A. Lack of lubrication and/or oil lag.
- B. Foreign material in the lubricating system.
- C. Oil oxidation or breakdown.
- D. Foreign material in either the exhaust or air induction systems.

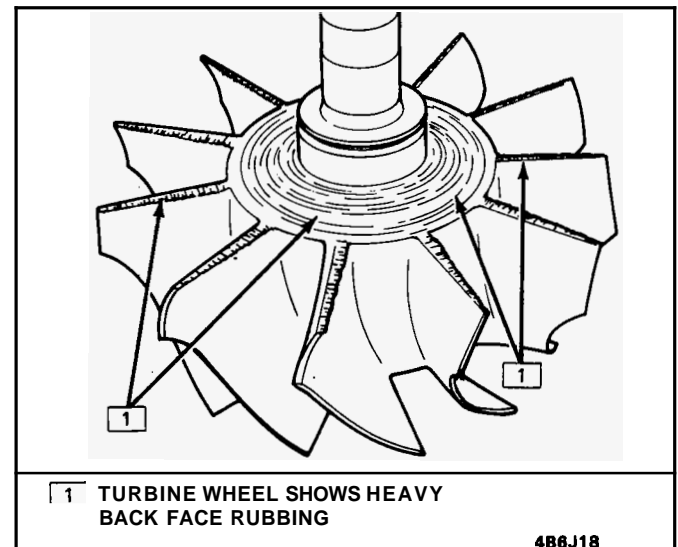

Figure 19

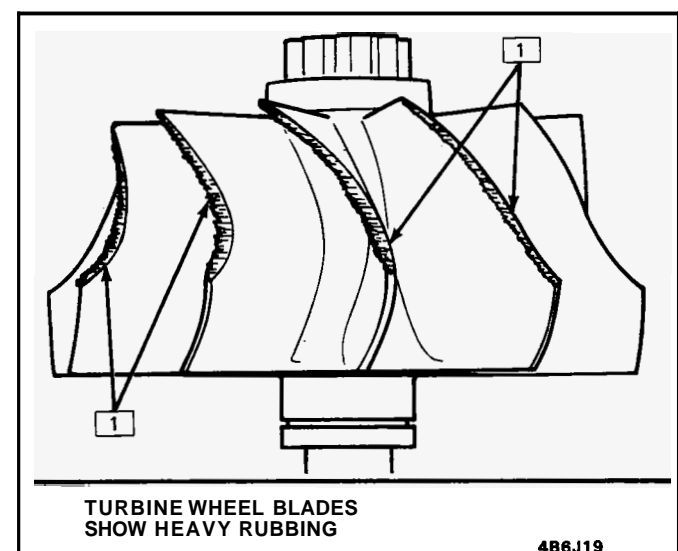

Figure 20

6J-10 TURBOCHARGER

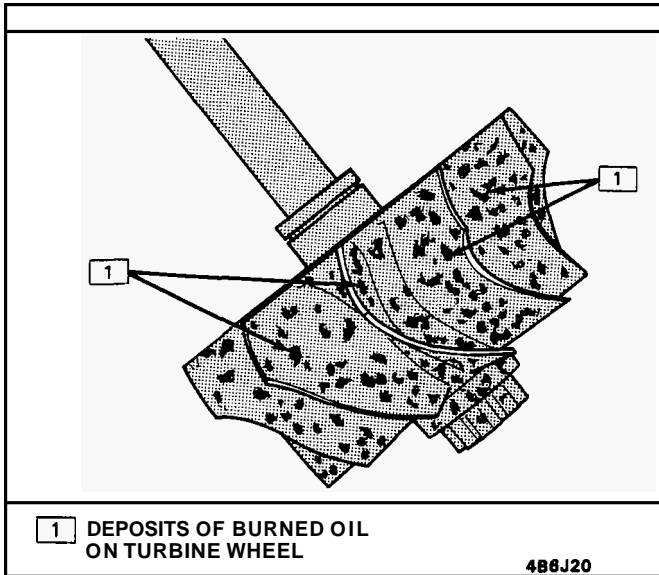

Figure 21

Causes of failure by type and corrective measures:

A. Lack of lubrication and/or oil lag.

1. This type of failure occurs when the oil pressure and flow is insufficient to:
 - a. Lubricate the journal and thrust bearings.
 - b. Stabilize the shaft and journal bearings.
 - c. Reach bearings before unit is accelerated to high speeds.
2. The turbocharger bearing's need for oil increases as the turbocharger speed and engine load increases. Insufficient oil to the turbocharger bearings for a period as short as a few seconds during a heavy load cycle when shaft speed is high will cause bearing failures.
3. General precautions: When oil and/or filters are changed.
 - a. First engine startup after oil and filter change: crank engine, if possible, without starting until the filter and oil system is filled and steady oil pressure is shown on the gage, or, start and run the engine at low idle long enough to obtain a steady oil pressure reading; otherwise, a bearing failure may result due to lag or lack of lubrication. Priming the oil filters with clean oil will reduce engine cranking time.
4. Engine starting procedure after installing a turbocharger:
 - a. Make certain that the oil inlet and drain lines are clean before they are connected. If hoses are used, make certain that they have not hardened and that the inner lining has not deteriorated and started to flake off. If metal tubing is used, make certain that it is not restricted or collapsed.
 - b. Make certain that the lube oil is clean and at operating level. The oil filter

- c. Leave the oil drain line disconnected at the turbocharger and crank the engine over without starting until oil flows out of the center housing drain port. A steady oil flow indicates that air pockets are out of lube oil system. A funnel can be used to return oil to drain tube.
- d. Connect the oil drain line, start the engine and operate at low idle rpm for a few minutes before loading engine.

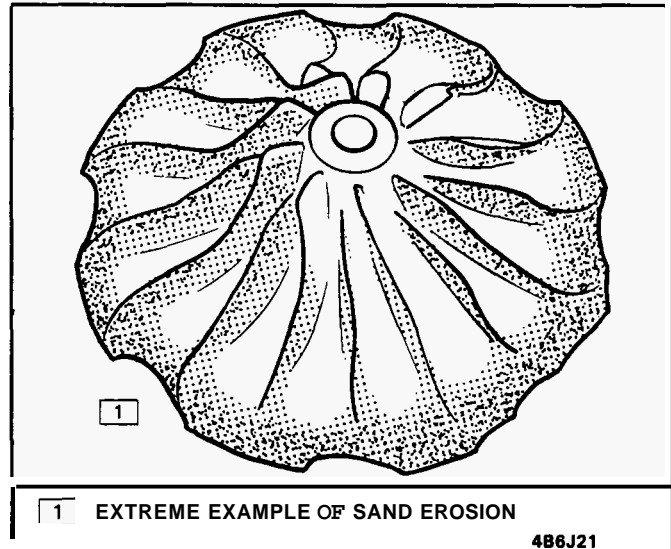

Figure 22

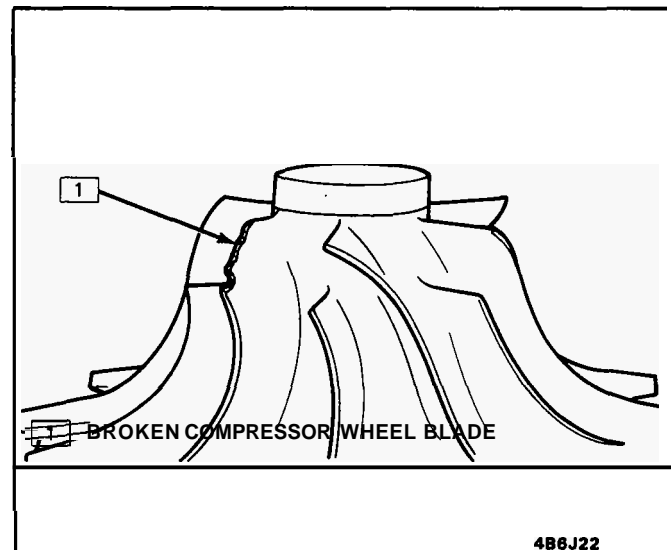

Figure 23

B. Foreign material in the lubricating system:

1. Operating an engine with contaminated or dirty oil and assuming that the oil filter will remove all contaminants before they reach the bearings can be costly to both the turbocharger and the engine. There are engine operating conditions when the oil completely bypasses the filter. Examples where the filter will be bypassed are:

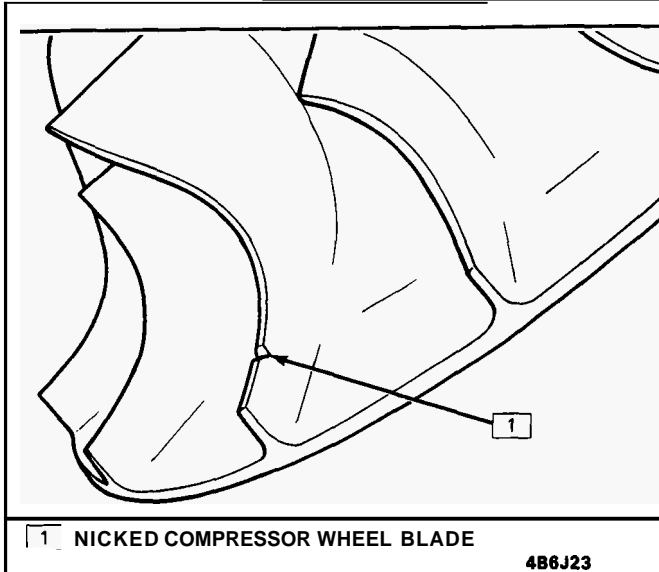

Figure 24

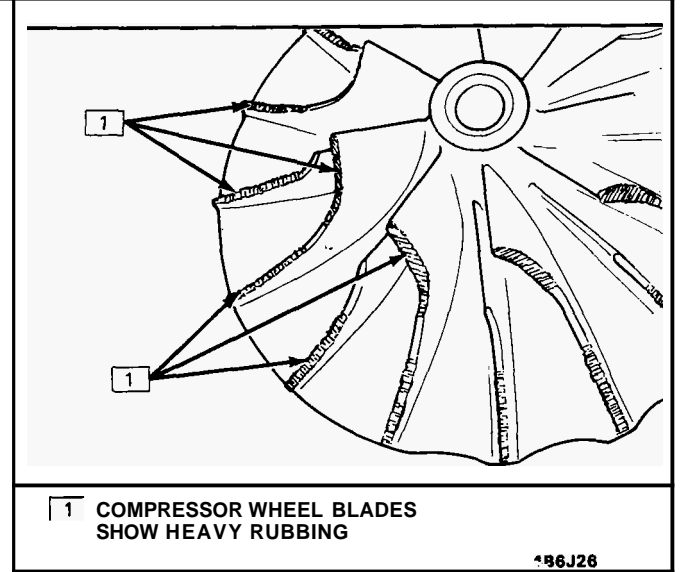

Figure 27

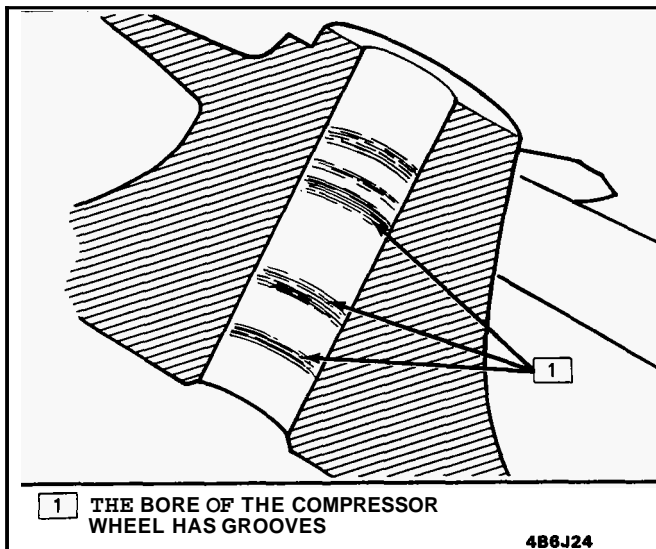

Figure 25

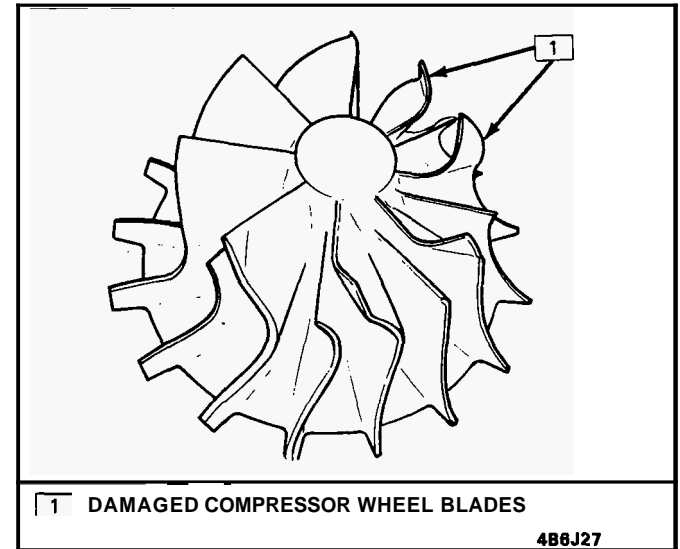

Figure 28

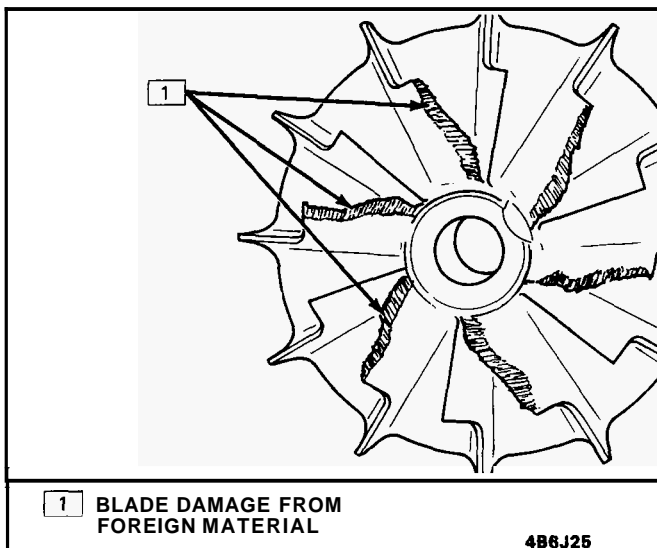

Figure 26

- a. Cold weather when the engine oil is congealed - filter bypass can be open.

- b. When oil filter is clogged - bypass can be open.
 - c. Filter bypass valve can stick in open or partly open position.
 - d. Filter element can be ruptured.
 - e. Filter element improperly installed.
2. Contaminated or dirty oil will wear and fail turbocharger bearings much sooner than it will fail engine bearings, because the turbocharger shaft rotates at a much higher speed than the engine. When this type of failure is found in a turbocharger, the cause of oil contamination should be located and corrected before installing a replacement turbocharger. If this is not accomplished, a second turbocharger failure will soon occur, along with the possibility of extensive engine damage. In addition, if contaminants are large enough to plug the turbocharger internal oil passages, a lack of lubrication type of failure would result. Analysis of oil samples at oil filter change periods can help to prevent this type of

failure. Oil and filter change periods should never be extended beyond the engine manufacturer's recommended interval.

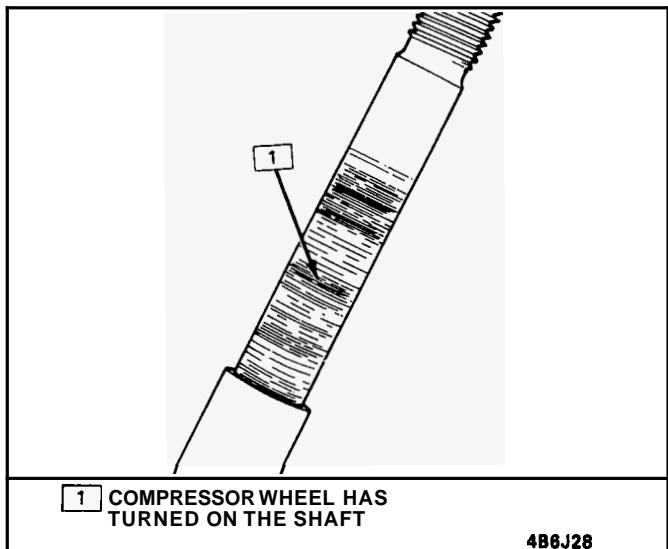

Figure 29

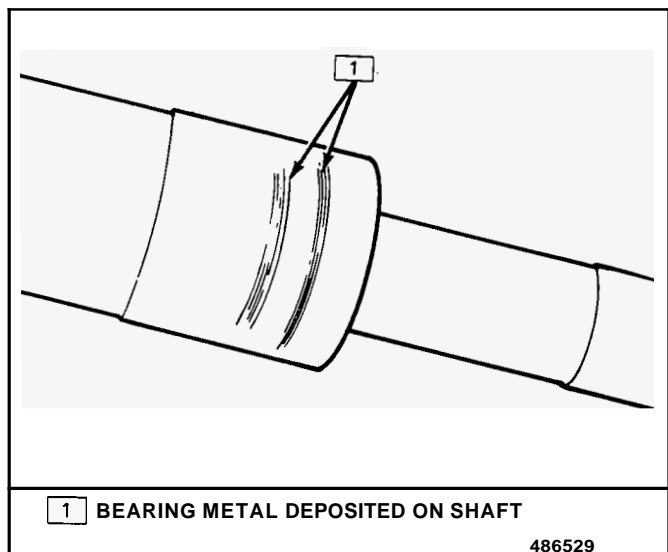

Figure 30

C. Oil oxidation or breakdown:

Sludge accumulates in engine oil when oxidation and/or oil breakdown takes place. Sludge will affect turbocharger performance and life, and eventually engine life, when the sludge condition of lubricating oil becomes severe.

The spinning action of the turbocharger shaft throws the oil against the internal walls of the center housing where sludge particles stick and accumulate. In time, it builds up to a point that oil drainage from the turbine and journal bearing is affected. Turbine seal leakage then occurs. The deposited sludge at the turbine end may become coked (baked) and very hard because of the high temperatures in this area. This hard coke can flake off and start wearing the turbine end journal bearing and bearing bore, but turbine seal leakage usually occurs first. Shaft rotation may or may

not be affected. In many cases, the journal bearing clearances are unchanged.

If turbine end oil leakage is encountered and it is suspected that sludge has built up at the turbine end of the center housing, center housing inspection can be made by looking through the oil drain opening. Heavy sludge build up will be seen on the shaft between the bearing journals and in the center housing from the oil drain opening on back to the turbine end when sludge and coked condition exists. In many cases, the turbocharger can be repaired by simply disassembling, cleaning and replacing a few kit-available parts.

important

- o When oil leakage is noted at the turbine end of the turbocharger, always check the turbocharger oil drain tube and the engine crankcase breathers for a restricted condition. Correct as necessary before working on the turbocharger.
- o When a sludged engine oil condition is found, it is mandatory that the engine oil and oil filters are changed, using the factory recommended lubricating oil.

Sludge accumulation results from oxidation and/or breakdown of the engine oil. Primary causes are engine overheating, excessive combustion products from piston blowby, non-compatible oils, engine coolant leaking into the oil, the wrong grade or quality of oil and the lack of proper oil change intervals.



Figure 31

D. Foreign material in either exhaust or air induction systems:

Foreign material which enters the exhaust or inlet air system will damage the wheels because of their extremely high speed. Small particles, such as sand, erode the leading edges of the blades. Large, hard particles tend to rip or tear the blades. Soft materials, such as shop towels or rubber items, roll the blades back, opposite the direction of the wheel rotation.

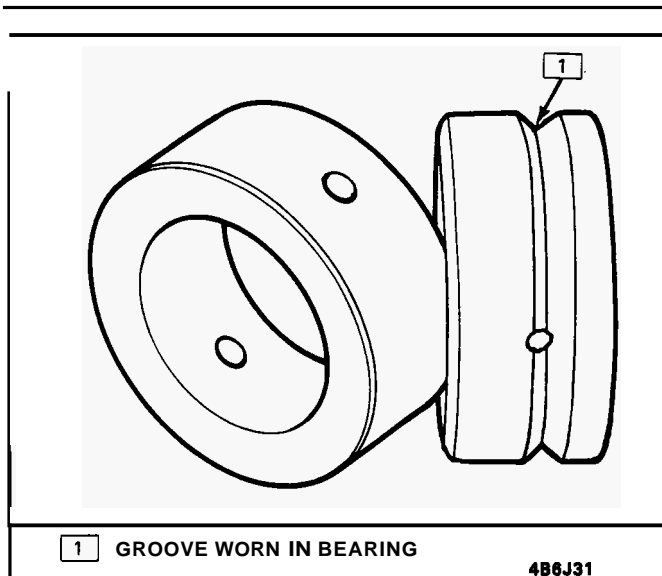

Figure 32

If there has been a turbocharger failure caused by foreign material damaging the wheels, a thorough cleaning of the exhaust manifold and inlet air system is essential.

It is extremely important to carefully service the turbocharger air inlet system. Be sure that no foreign objects are in the piping and that all connections are secure.

ON-CAR SERVICE

2.0 LITER VIN M

TURBOCHARGER

See Figure 33

↔ Remove or Disconnect

1. Raise car and suitably support. See Section OA.
2. Lower fan retaining screw.
3. Exhaust pipe.
4. Bolt - Rear A/C support bracket, loosen remaining bolts.
5. Bolt - Turbo support bracket to engine.
6. Oil drain hose at turbo.
7. Water return pipe
8. Lower vehicle.
9. Coolant recovery pipe and move to one side.
10. Induction tube.
11. Coolant fan.
12. Oxygen sensor.
13. Oil feed pipe at union.
14. Water feed pipe
15. Air intake duct and vacuum hose at actuator.
16. Exhaust manifold retaining nuts.
17. Exhaust manifold and turbocharger.

⊠ Disassemble

1. Oil feed pipe.
2. Oxygen sensor.
3. Actuator assembly.
4. Support bracket.
5. Exhaust elbow.
6. Turbocharger.

□ Inspect

- For foreign material and determine its source.
- See Unit-Inspection.

□ important

- The turbocharger is a precision built component and should be serviced by factory trained technicians only.

→X← Assemble

1. Turbocharger to manifold.
2. Exhaust elbow.
3. Support bracket.
4. Actuator assembly.
5. Oxygen sensor.
6. feed pipe.

Clean

- Mating surfaces at cylinder head and manifold.

→← Install or Connect

1. Exhaust manifold and turbocharger with new manifold gasket.
2. Retaining nuts and washers.

Tighten

- In sequence and to specifications
- 3. Oil feed lines.
- 4. Water feed & return lines
- 5. Oxygen sensor.
- 6. Air intake duct and vacuum hose to actuator.
- 7. Cooling fan and upper screws.
- 8. Induction tube.
- 9. Coolant recovery pipe.

6J-14 TURBOCHARGER

10. Raise car and suitably support. See Section OA.
11. Bolt - rear turbo support.
12. A/C support.
13. Oil drain hose.
14. Lower fan screw.
15. Exhaust pipe.

Inspect

- o For Intake leaks.
- o For Exhaust leaks.

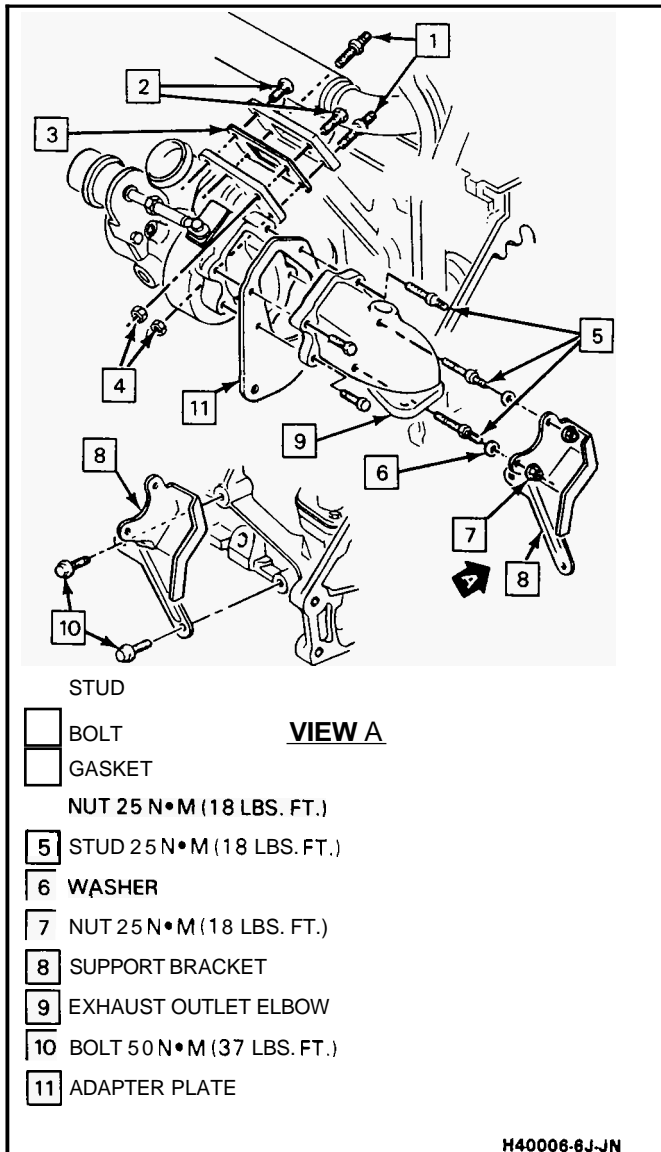

Figure 33 Turbocharger Mounting

WASTEGATE ACTUATOR

Remove or Disconnect

1. Induction tube.
2. Clip - Actuator rod to wastegate.
3. Vacuum hose.
4. Retaining screws - Actuator to turbo.
5. Actuator assembly.

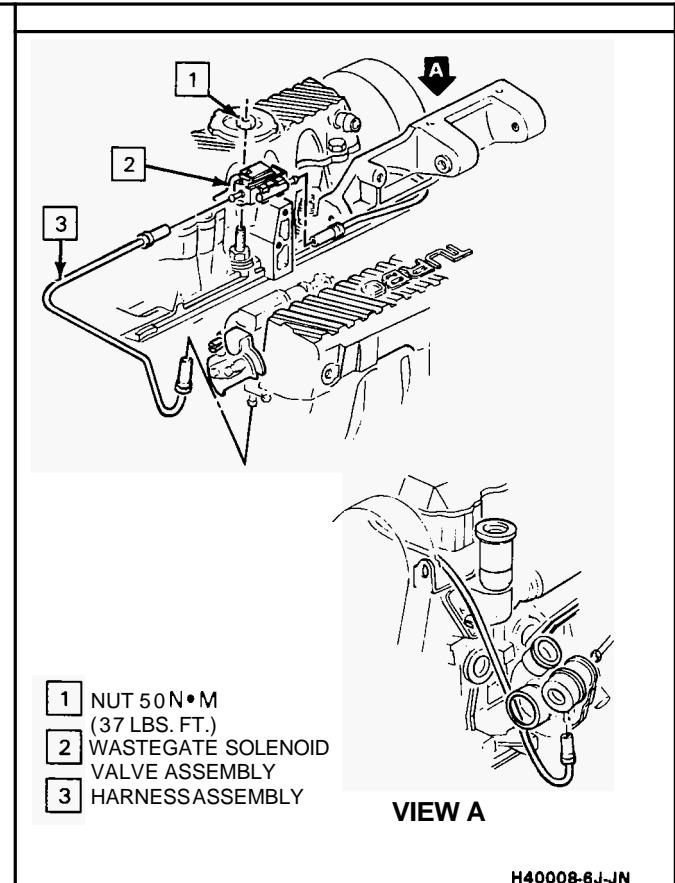

Figure 34 Wastegate Solenoid Valve Assembly & Harness

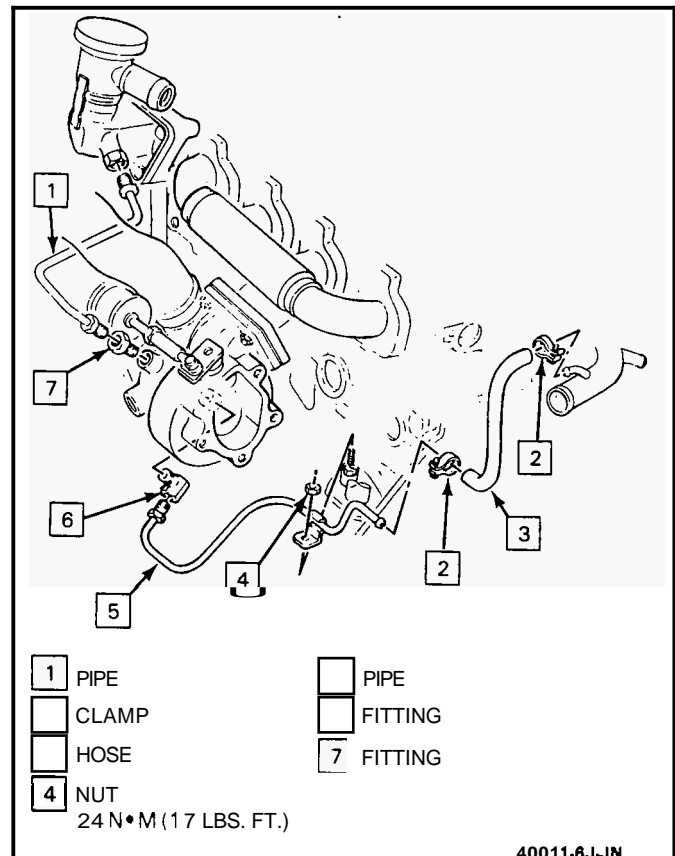

Figure 35 Water Feed and Return Pipes

Install or Connect

1. Actuator assembly and retaining screws.
2. Vacuum hose.
3. Clip - Actuator rod to wastegate.
4. Induction tube.

Inspect

- o See Wastegate/Boost Pressure Test, steps 3 and 4.

INTAKE MANIFOLD

See Figures 34 thru 38

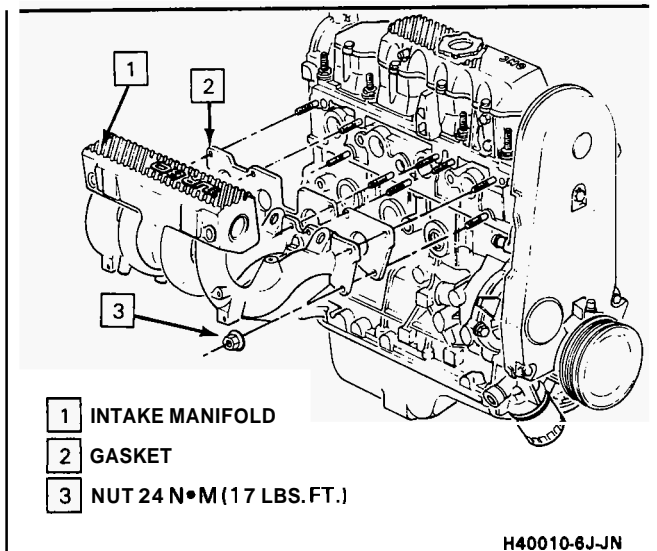

Figure 36 Intake Manifold

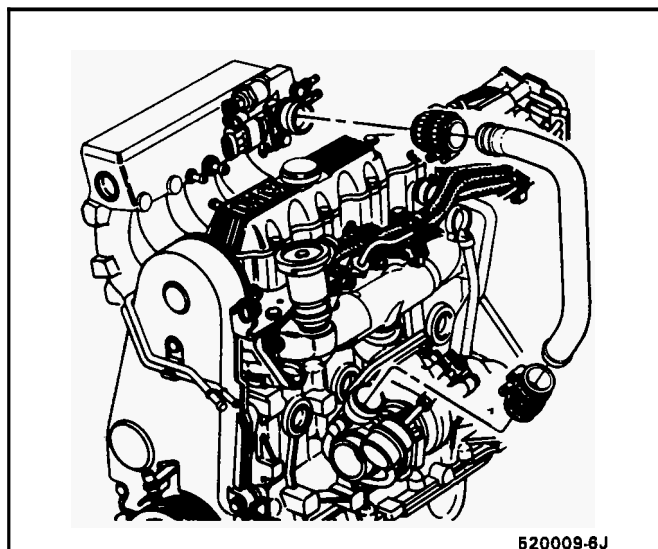

Figure 37 Turbo Induction Tube and Hoses

Remove or Disconnect

1. Induction tube and hoses.
2. Wiring to throttle body, M.A.P. sensor and wastegate.
3. PCV hose.
4. Hose, vacuum to throttle body.

5. Throttle cable and cruise control cable (if applicable).
6. Wiring, to ignition coil.
7. Manifold support bracket.
8. Wiring to fuel injectors.
9. Bolt rear generator bracket to generator.
10. Power steering adjusting bracket.
11. Generator front adjusting bracket.
12. Fuel lines to fuel rail inlet and regulator outlet.
13. Retaining nuts and washers.
14. Manifold and gasket.

- o If installing new manifold, transfer all necessary parts from old manifold to new manifold.

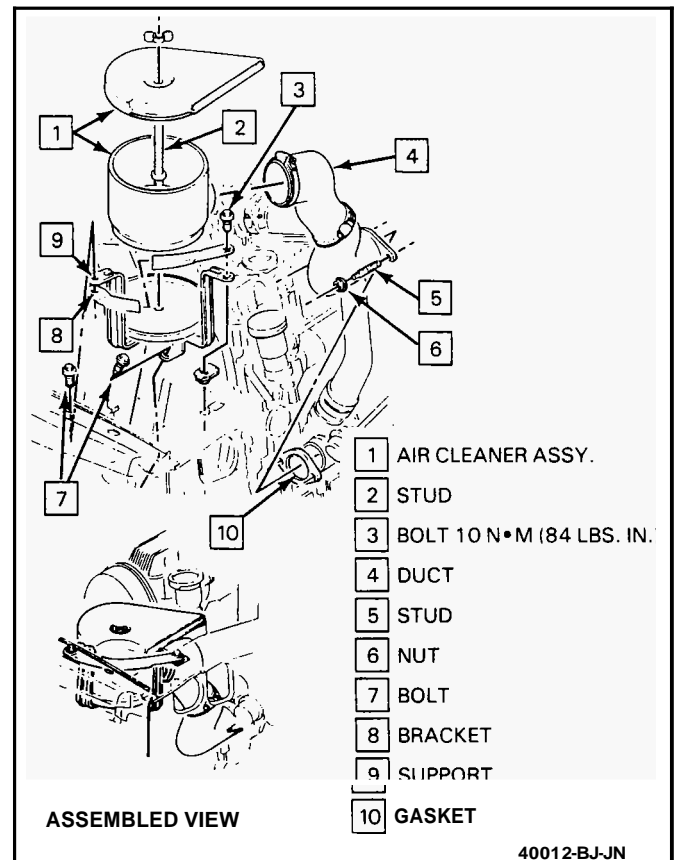

Figure 38 Air Cleaner and Intake Duct

Clean

- o Mating surfaces at cylinder head and manifold.

Install or Connect

1. Intake manifold with new gasket.
2. Retaining nuts and washers. Torque to **25 N•m (18 lb.ft.)**.
3. Fuel lines.
4. Power steering and generator adjusting brackets.

Important

- o Any time the rear power steering adjusting bracket is loosened or removed, proper adjusting bolt torque sequence is essential for belt and

pulley alignment, The rear adjusting bracket must be the last part secured to prevent distorting the accessory drive system to prevent the belt from coming off. See Section 3B for torque sequence.

5. Wiring to fuel injectors.
6. Wiring to ignition coil.
7. Throttle cable and cruise control cable (if applicable).
8. Vacuum hoses and PCV hose.
9. Wiring to throttle body, M.A.P. sensor and wastegate.
10. Induction tube and hoses.

 **Inspect**

- o For vacuum leaks.
- o For correct completion of repair.

EXHAUST MANIFOLD

See Figure 39

 **Remove or Disconnect**

1. Turbo induction tube.
2. Spark plug wires.
3. Bolts and nuts turbo to exhaust manifold.
4. Retaining nuts, manifold and gasket.

 **Clean**

- o Mating surfaces at cylinder head and manifold.

 **Install or Connect**

1. Exhaust manifold with new gasket, torque nuts to 22 N·m (16 lb.ft.).
2. Turbocharger to exhaust manifold, torque nuts to 25 N·m (18 lb.ft.).

3. Spark plug wires.
4. Turbo induction tube.

 **Inspect**

- o Exhaust leaks.

TURBOCHARGER OIL PIPE & HOSE ROUTING

See Figures 40 thru 42

WASTEGATE/BOOST PRESSURE TEST PROCEDURE

 **Inspect**

1. Actuator and wastegate mechanical linkage for damage.
2. Hose from the throttle body to the wastegate solenoid and from the wastegate solenoid to the actuator assembly.
3. Attach hand operated vacuum/pressure pump J 23738, in series with component gage J 28474 to actuator assembly, replacing wastegate solenoid to actuator assembly hose.
4. Apply pressure to actuator assembly. At approximately 4 psi (3.5 to 4.5 psi) the actuator rod end should move .015", actuating the wastegate linkage. If not, replace the actuator assembly and check that opening calibration pressure is 4 psi. Crimp adjustment barrel on actuator rod to maintain correct calibration.
5. Remove test equipment and reconnect wastegate solenoid to actuator assembly hose and clamps.

 **Important**

- o Any service procedure or diagnosis to fuel injectors see Section 6E.
- o Do Not Apply 12 Volts Directly to Injector, this will result in damage to the injector and replacement.

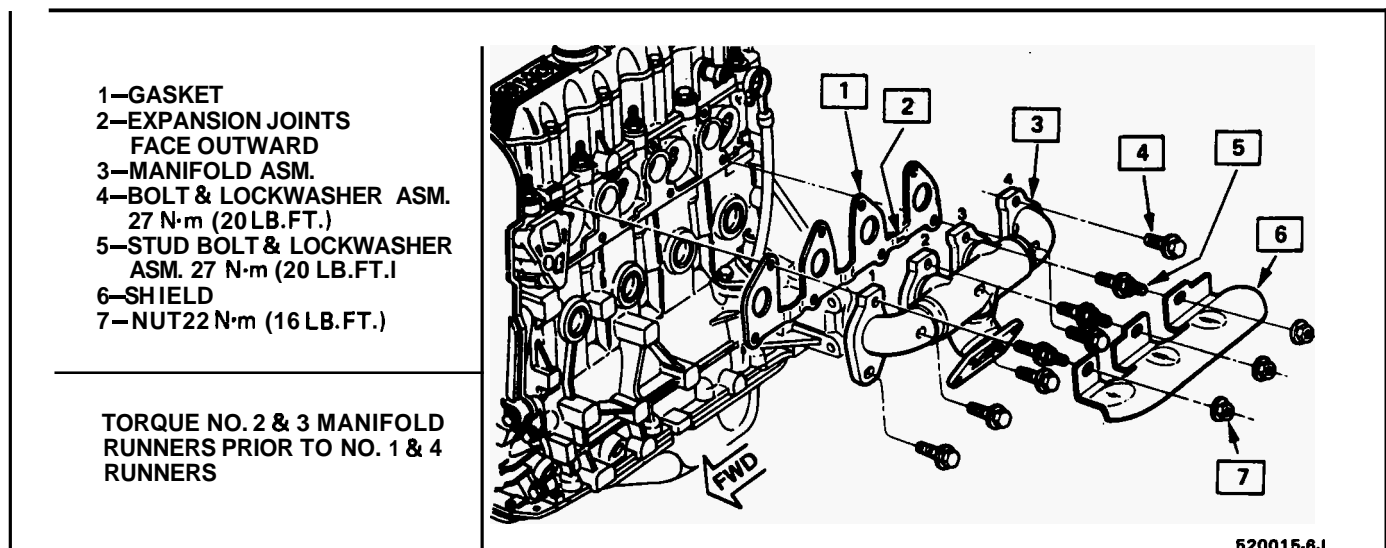

Figure 39 Exhaust Manifold Asm. and Gasket

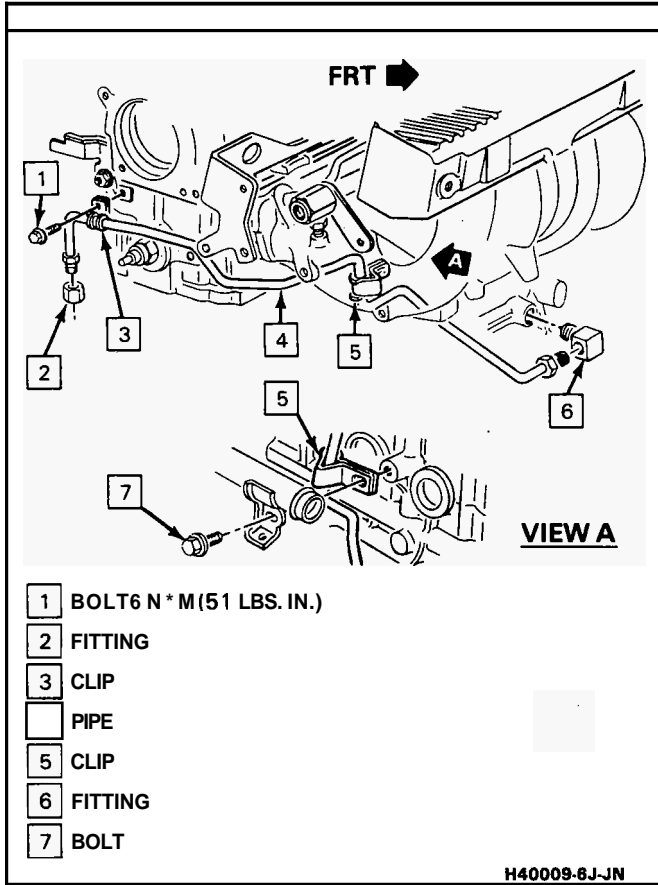

Figure 40 Turbo Oil Feed (RH)

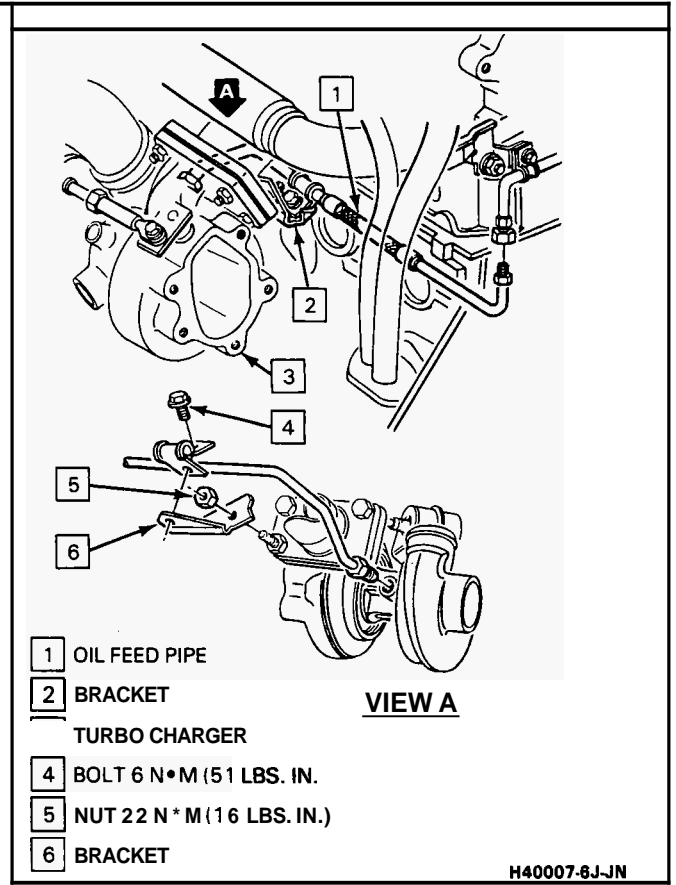

Figure 41 Turbo Oil Feed (LH)

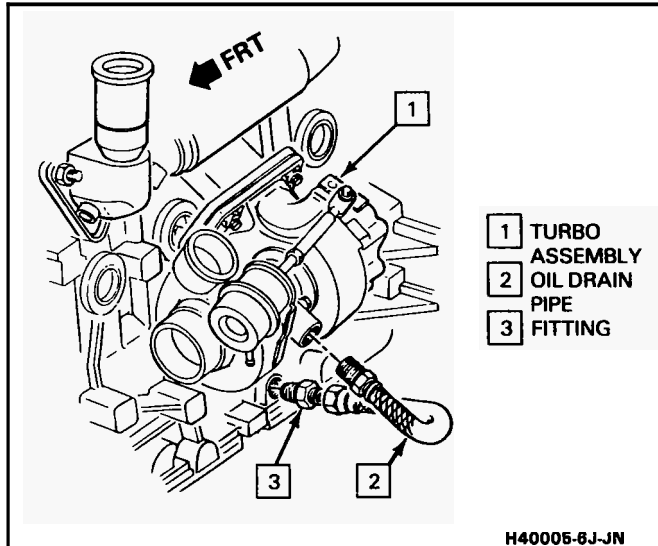

Figure 42 Turbo Oil Drain Hose

2.0 LITER TORQUE SPECIFICATIONS

Torque	N·m	Lb.Ft.
Turbocharger to exhaust manifold	25	18
Turbo outlet elbow to turbocharger	25	18
Turbo support bracket:		
Lower bolt	50	37
Retaining nut	25	18

6J-18 TURBOCHARGER

Torque	N·m	Lb.Ft.
Exhaust pipe to elbow	25	18
Oil feed pipe to turbo	17	12
Oil feed pipe-union	17	12
Oil feed pipe to block	17	12
Oil drain hose (both ends)	47	35
Exhaust manifold	22	16
Intake manifold	25	18
Throttle body	25	18

3.8 LITER-VIN 7

TURBOCHARGER-G CARLINE

See Figures 43 thru 52

Remove or Disconnect

1. Air inlet hose from compressor section of turbocharger
2. Compressor outlet pipe from compressor
3. Turbocharger and oil breather heat shields
4. Exhaust pipe from turbine outlet
5. Oil breather vent from valve cover
6. Oil feed line
7. Turbocharger to bracket nuts (2)
8. Turbine inlet from exhaust manifold
9. Oil return line from turbocharger
10. Vacuum lines from turbo wastegate actuator
11. Intercooler outlet to throttle body pipe
12. Turbocharger from engine

Inspect

- o All air passages for foreign material
- o Turbocharger for wear, oil leaks, and bent blades on the turbine or compressor wheel

Install or Connect

1. Turbocharger to engine
2. Start exhaust manifold to turbocharger bolts
3. Start exhaust pipe to turbine outlet
4. Oil return line
5. Turbocharger to mounting bracket nuts
6. Tighten exhaust pipe to turbocharger
7. Tighten turbocharger to exhaust manifold
8. Oil feed line
9. Oil breather vent
10. Vacuum lines to wastegate actuator
11. Compressor outlet pipe
12. Intercooler outlet pipe
13. Turbocharger and oil breather heat shields
14. Air inlet hose to compressor
 - o Boost pressure (see Wastegate/Boost Pressure Test Procedure)

WASTEGATE ACTUATOR

Remove or Disconnect

1. Vacuum hose at actuator

2. Retaining clip at actuator rod to wastegate lever
3. Two bolts attaching mounting bracket to compressor housing
4. Wastegate actuator

Install or Connect

1. Wastegate actuator
2. Two bolts attaching mounting bracket to compressor housing
3. Retaining clip at actuator rod to wastegate lever
4. Vacuum hose at actuator

Adjust

- o Boost pressure (see Wastegate/Boost Pressure Test Procedure)

INTAKE MANIFOLD

See Figure 44

Remove or Disconnect

1. Drain coolant
2. Air inlet tube
3. Fuel line at fuel rail (inlet) and at pressure regulator (return)
4. Injector wiring harness connectors (2) located just behind the coil
5. Coolant temperature sensor wire connectors (2) located at the front of the manifold
6. Coolant hoses:
 - o Heater
 - o Bypass
 - o Upper radiator
7. Vacuum lines and hoses:
 - o EGR
 - o Fuel pressure regulator
 - o PCV
8. Cables from throttle body:
 - o Throttle
 - o Cruise
 - o T.V.
9. EGR vacuum control valve
10. Ignition wires from spark plugs.
11. Intake manifold bolts
12. Intake manifold

Clean

- o Intake manifold gasket and seal mating surfaces

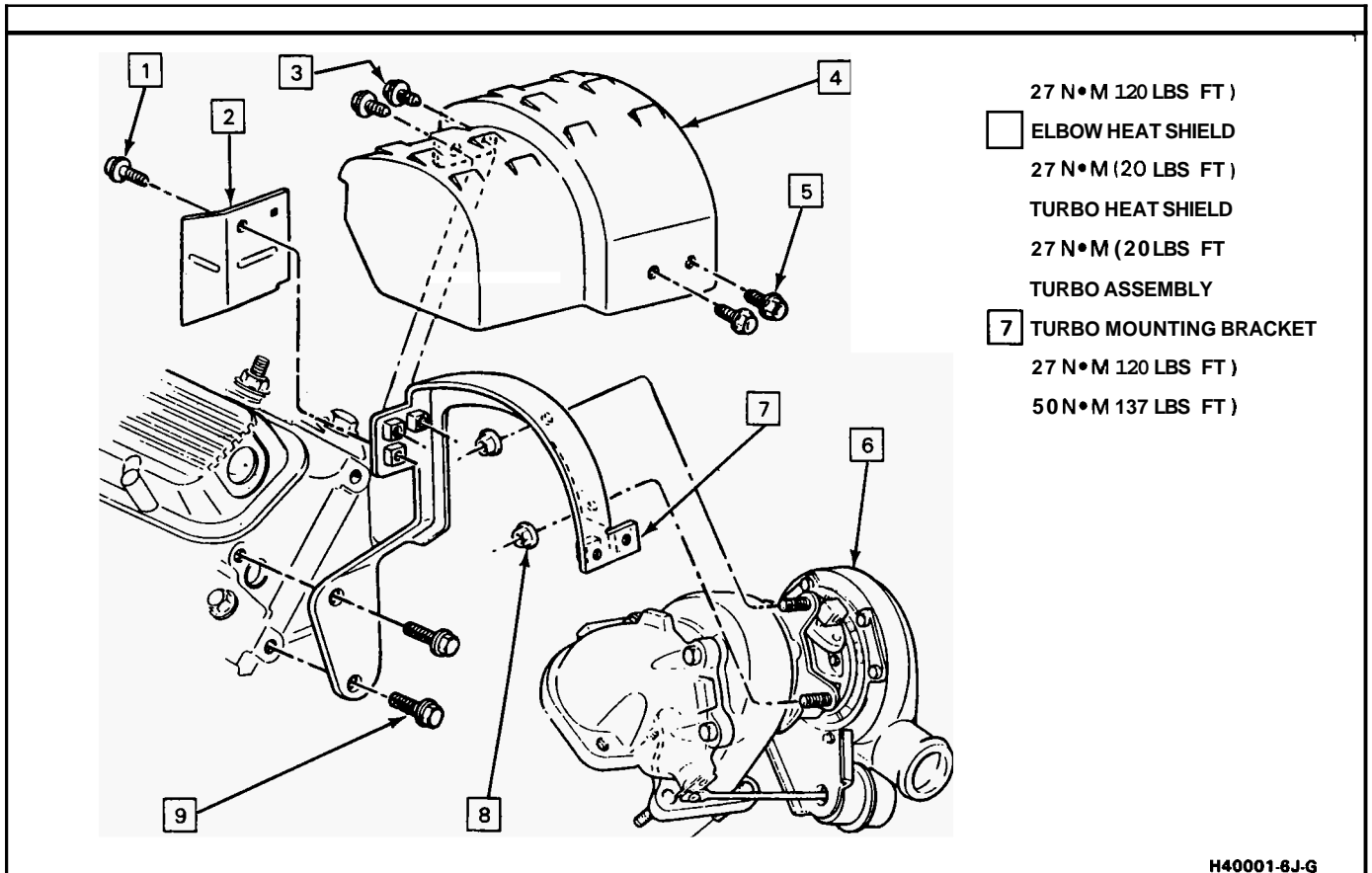

Figure 43 Turbocharger Assembly

H40001-6J-G

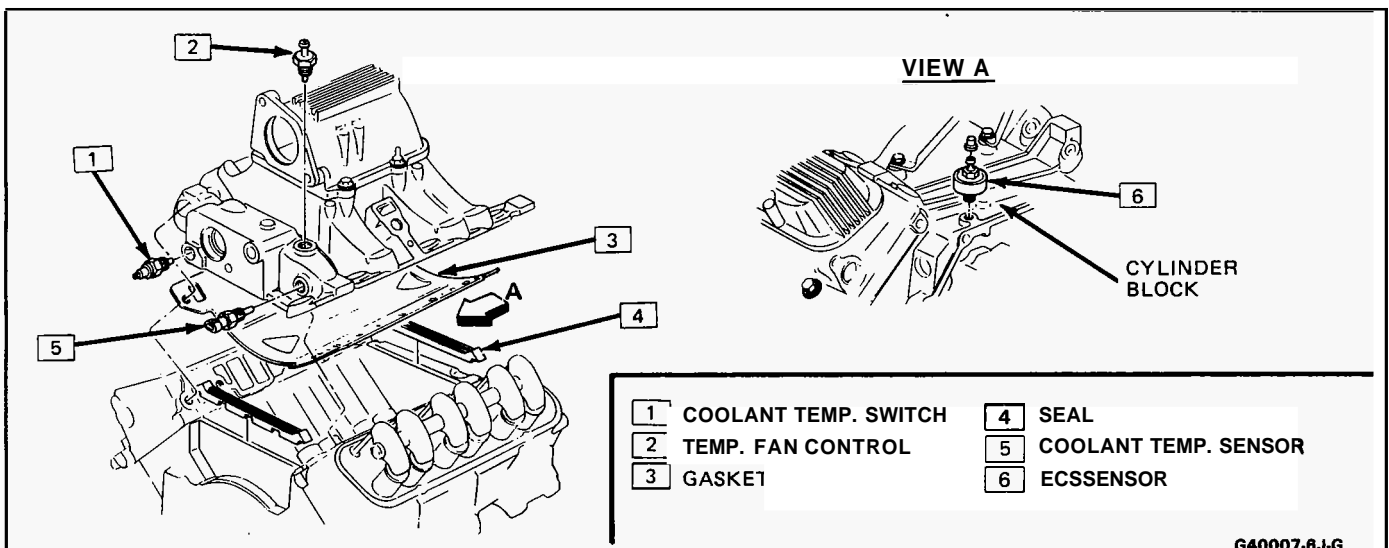

Figure 44 Intake Manifold, Gasket and Dress Items

G40007-8J-G

→← Install or Connect

1. Intake manifold gasket and end seals
2. Intake manifold and attaching bolts
3. Lower right-side turbo mounting bracket to intake and bracket support to plenum
4. Vacuum lines and hoses:
 - o EGR
 - o Fuel pressure regulator
 - o PCV
5. Coolant hoses:
 - o Heater
 - o Bypass
 - o Upper radiator
6. Coolant temperature sensor wire connectors (2)
7. Injector wiring harness connectors (2)
8. Fuel line at fuel rail (inlet) and at pressure regulator (return)
9. Refill cooling system

6J-20 TURBOCHARGER

10. Cables to throttle body:
 - o Throttle
 - o Cruise
 - o T.V.
11. EGR vacuum control valve
12. Ignition wires from spark plugs
13. Air inlet tube

EXHAUST MANIFOLD

See Figures 45 thru 47

Left

Remove or Disconnect

1. Raise car and suitably support. See Section OA.
2. Exhaust manifold to crossover pipe
3. Lower car.
4. Exhaust manifold to cylinder head bolts (6)
5. Exhaust manifold

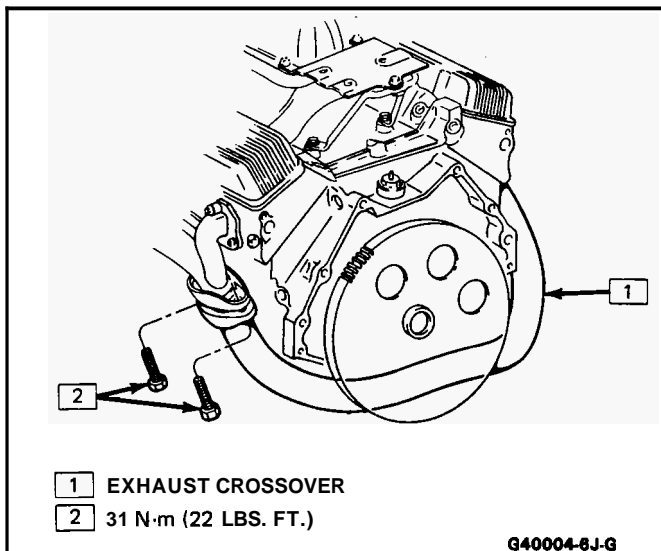

Figure 45 Crossover Pipe 3.8L Turbo

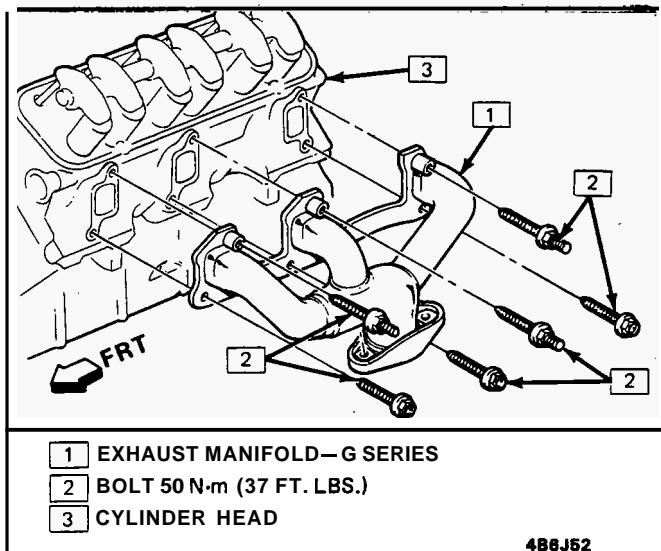

Figure 47 Left Exhaust Manifold-G Carline

Clean

- o All mating surfaces and inspect for cracks or leaks

Install or Connect

1. Exhaust manifold
2. Exhaust manifold to cylinder head bolts
3. Raise car and suitably support. See Section OA.
4. Exhaust manifold to crossover pipe
5. Lower car.

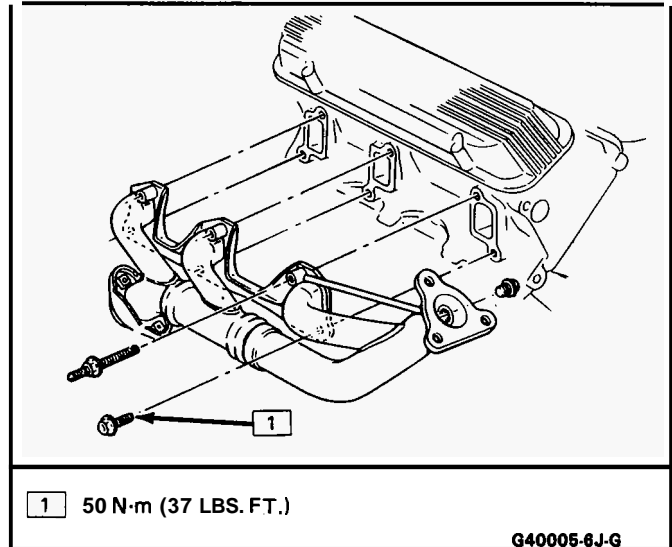

Figure 46 Right Exhaust Manifold-G Carline

Right

Remove or Disconnect

1. Exhaust pipe from turbocharger
2. Oxygen sensor wire
3. Raise car and suitably support. See Section OA.
4. Crossover from exhaust manifold
5. Lower car.
6. Exhaust manifold to cylinder head bolts (6)
7. Exhaust manifold

Install or Connect

1. Exhaust manifold
2. Exhaust manifold to cylinder head bolts
3. Raise car and suitably support. See Section OA.
4. Crossover to exhaust manifold
5. Lower car.
6. Oxygen sensor wire
7. Exhaust pipe to turbocharger

Intercooler Removal

See Figure 52

Remove or Disconnect

1. Shroud from intercooler

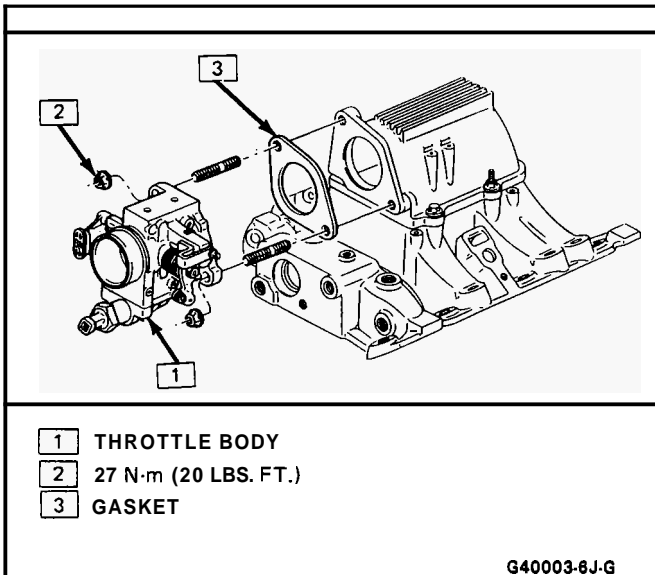

Figure 48 Throttle Body Attachment

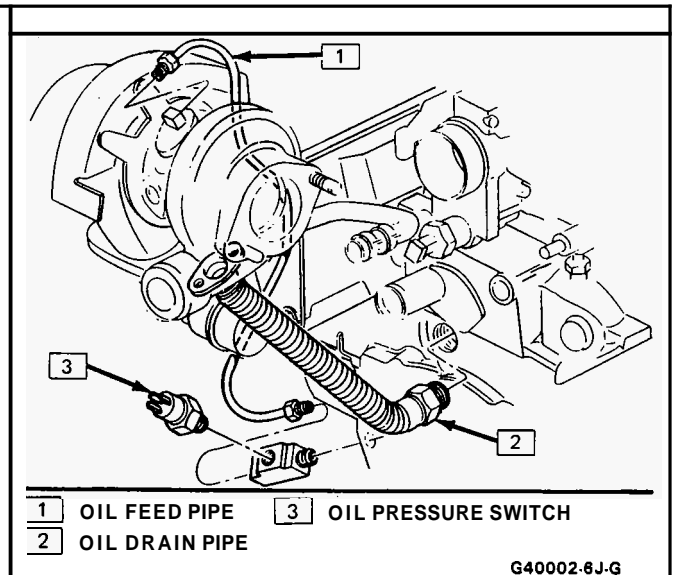

Figure 50 Oil Supply & Return Line Routing

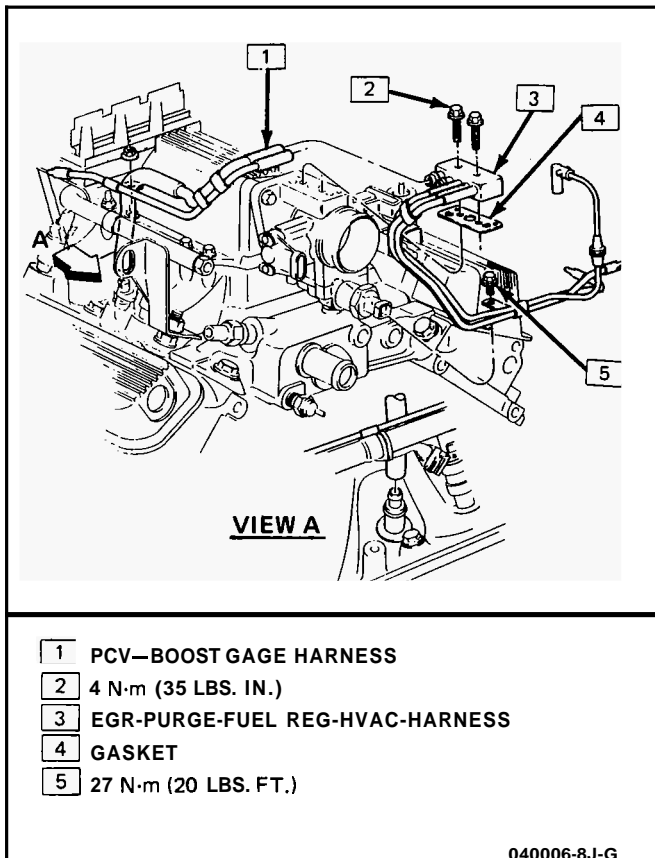

Figure 49 Vacuum Hose and Line Routings

2. Intercooler inlet pipe from turbocharger
3. Intercooler outlet pipe throttle body and intercooler
4. Intercooler to mounting bracket bolts (4)
5. Intercooler

Install or Connect

1. Intercooler to mounting brackets
2. Intercooler outlet pipe to intercooler and throttle body
3. Intercooler inlet pipe to turbocharger
4. Shroud to intercooler

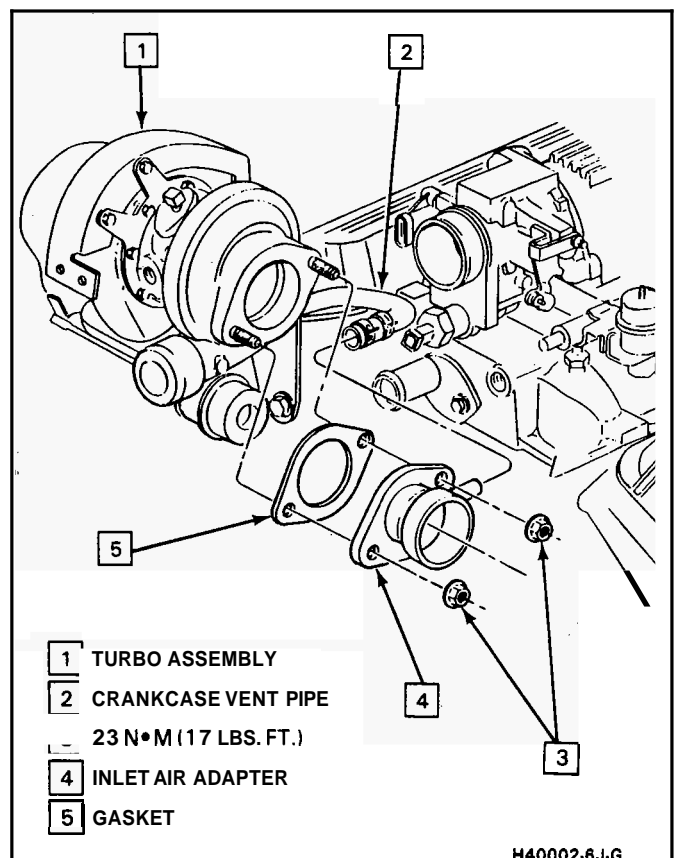

Figure 51 Inlet Air Adapter to Turbocharger

WASTEGATE/BOOST PRESSURE TEST PROCEDURE

Tools Required:

- J 23738 Vacuum/Pressure Pump
- J 28474 Compound Gage

Inspect

1. Wastegate-actuator mechanical linkage for damage.
2. Hoses to actuator assembly
3. Attach hand operated vacuum/pressure pump J 23738, in series with compound gage J 28474 to actuator assembly.

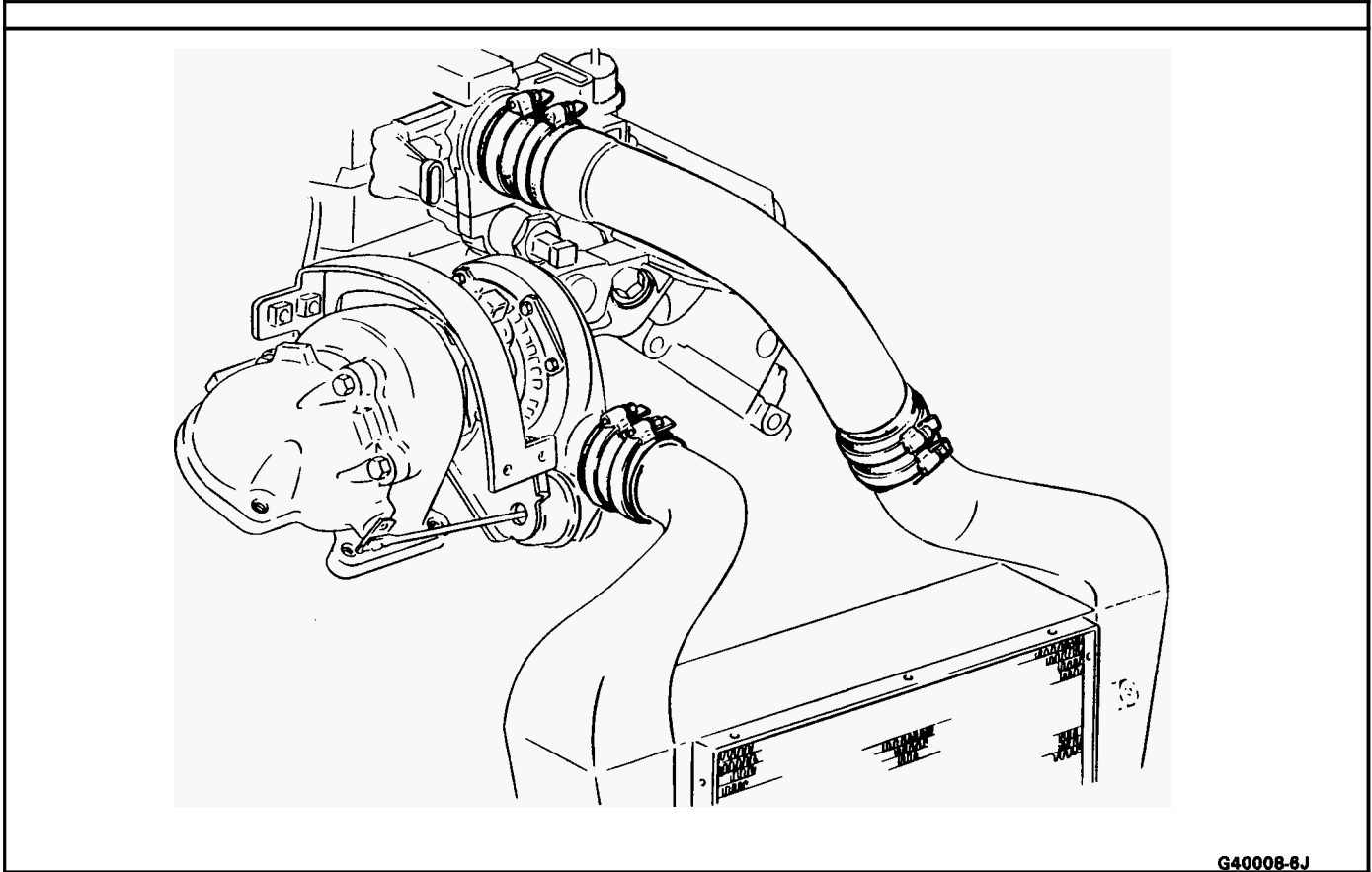

G40008-6J

Figure 52 Intercooler to Engine

4. Apply pressure to actuator assembly.
 - o At approximately 13 1/2 psi the actuator rod end should move .015 in., actuating the wastegate linkage.
 - o If this does not occur, replace the actuator assembly and test for proper calibration.
 - o Crimp the threads on actuator rod to maintain correct calibration.
5. Remove test equipment and reconnect hoses as shown in the vacuum schematics.
6. An alternative method of checking wastegate operation is to perform a road test which measures boost pressure.

- o Boost pressure as measured by the compound gage during road testing should reach 13-14 psi.
- o If this does not occur, replace the actuator assembly and test for proper calibration.

TURBOCHARGER INTERNAL INSPECTION PROCEDURE

See Figures 53 & 54

Inspect

- o For loose backplate to CHRA bolts
- o Tighten or replace as necessary.
- o For missing gasket or "O" ring
- o Check the journal bearings for radial clearance as follows:

1. Attach a dial indicator, with a two inch long, 3/4 to one inch offset extension rod to the center housing such that the indicator plunger extends through the oil outlet port and contacts the shaft of the rotating assembly. If required, a dial indicator mounting adapter can be used.
2. Manually apply pressure, equally and at the same time, to both the compressor and turbine wheels, as required, to move the shaft away from the dial indicator plunger as far as it will go.
3. Set the dial indicator to zero.
4. Manually apply pressure, equally and at the same time, to both the compressor and

ROAD TEST

Tool Required:

J 28474 Compound Gage

1. Tee compound gage J 28474 into tubing between compressor housing and boost gage or MAP sensor switch with sufficient length of hose to place gage in passenger compartment.

CAUTION: Determine that hose and compound gage are in proper operating condition to avoid possible leakage of air-fuel mixture into passenger compartment during road test, possibly causing bodily injury.

2. Disconnect hose at Wastegate Solenoid and Plug
3. Conditions and speed limits permitting, perform a zero to 40 or 50 mph wide open throttle acceleration.

turbine wheels to move the shaft toward the dial indicator plunger as far as it will go. Note the maximum value on the indicator dial.

Make sure that the dial indicator reading noted is the maximum reading obtainable, which can be verified by rolling the wheels slightly in both directions while applying pressure.

5. Manually apply pressure, equally and at the same time to the compressor and turbine wheels, as required, to move the shaft away from the dial indicator plunger as far as it will go. Note that the indicator pointer returns exactly to zero.
6. Repeat steps (2) through (5), as required, to make sure that the maximum clearance between the center housing bores and the shaft bearing diameters, as indicated by the maximum shaft travel, has been obtained.
7. If the maximum bearing radial clearance is less than 0.003 inch, or greater than 0.006 inch, replace CHRA and inspect housings.

NOTICE: Continued operation of a turbocharger having improper bearing radial clearance will result in severe damage to the compressor wheel and housing or to the turbine wheel and housing.

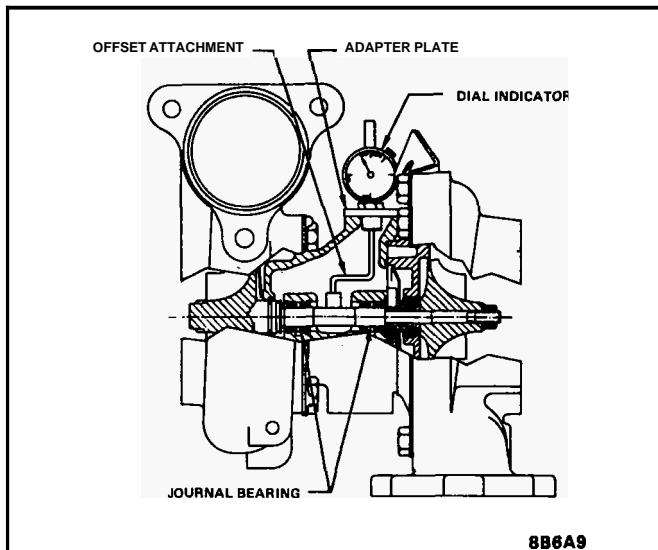

Figure 53 Journal Bearing Clearance Check

- Check for thrust bearing axial clearance as follows:
 1. Mount a dial indicator at the turbine end of the turbocharger such that the dial indicator tip rests on the end of the turbine wheel.
 2. Manually move the compressor wheel and turbine wheel assembly alternately toward and away from the dial indicator plunger. Note the travel of the shaft in each direction, as shown on the dial indicator.
 3. Repeat Step (2), as required, to make sure that the maximum clearance between the thrust bearing components has been obtained.
 4. If the maximum thrust bearing axial clearance is less than 0.001 inch, or greater than 0.003 inch, replace CHRA and inspect housings.

NOTICE: Continued operation of a turbocharger having an improper amount of thrust bearing axial clearance will result in severe damage to the compressor wheel and housing or to the turbine wheel and housing.

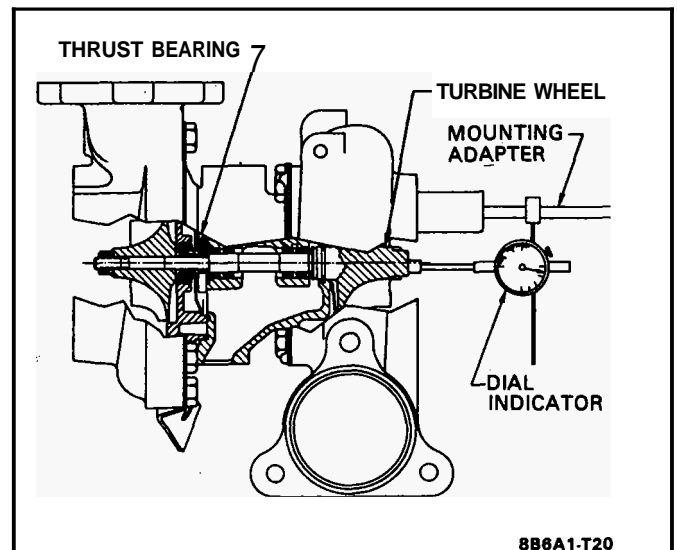

Figure 54 Thrust Bearing Clearance Check

3.8 LITER TORQUE SPECIFICATIONS

TORQUE	N·m	LB. FT.
Exhaust Manifold (Right) to Turbine Housing	27	20
Exhaust Inlet Pipe to Right Exhaust Manifold	31	23
Oil Feed Pipe to Fitting at Turbo	10	7
CHRA to Turbine Housing	20	15
CHRA to Compressor Housing	17	13
Throttle Body to Intake Manifold	27	20
Oil Drain to CHRA	30	22
Support Bracket to Cylinder Head	50	37
Intake Manifold to Cylinder Head	60	44
Exhaust Manifold to Cylinder Head	50	37
Turbo to Support Bracket Nuts	27	20
Turbo Heat Shield to Support Bracket	27	20