

SECTION 4A

PROPELLER SHAFT

NOTICE: The propeller shaft to pinion yoke fasteners are important attaching parts in that they may affect the performance of vital components and systems, which may result in major repair expense. They must be replaced with one of the same part number or with an equivalent part, if replacement becomes necessary. Do not use a replacement part of lesser quality or substitute design. Torque values must be used as specified during reassembly to assure proper retention of these parts.

CONTENTS

General Description	4A-1	Propeller Shaft Balancing Procedure	4A-6
Diagnosis	4A-2	Propeller Shaft	4A-8
On-Car Service		Unit Repair	
Checking Universal Joint Angle	4A-2	Universal Joints	4A-9
Checking Propeller Shaft Runout	4A-4	Specifications	4A-11
Pinion Yoke Runout	4A-7	Special Tools	4A-11

GENERAL DESCRIPTION

See Figure 1

A universal joint and splined slip yoke are located at the transmission end of the propeller shaft, where they are held in alignment by a bushing in the rear of the transmission. The slip yoke permits fore and aft movement of the propeller shaft, as the differential assembly moves up and down. The spline is lubricated internally by transmission lubricant. An oil seal at the transmission prevents leakage and protects the slip yoke from dust, dirt, and other harmful material.

A second universal joint is used where the propeller shaft mates with the pinion yoke at the rear.

The universal joints are lubricated for life and cannot be lubricated. A service kit which consists of a

spider with bearing assemblies and snap rings must be installed on the car if a universal joint becomes worn or noisy. If it becomes necessary to repair a universal joint, the entire propeller shaft must be removed from the car. Care should be taken to avoid jamming, bending or over-angulating of any parts of the assembly.

If a car is to be undercoated, the propeller shaft must be kept completely free of undercoating material. Undercoating material or any other foreign material will upset the propeller shaft balance and produce a serious vibration.

On all carlines, production universal joint bearings are retained by a nylon injected ring instead of the conventional snap ring. All service universal joints however, will use snap rings.

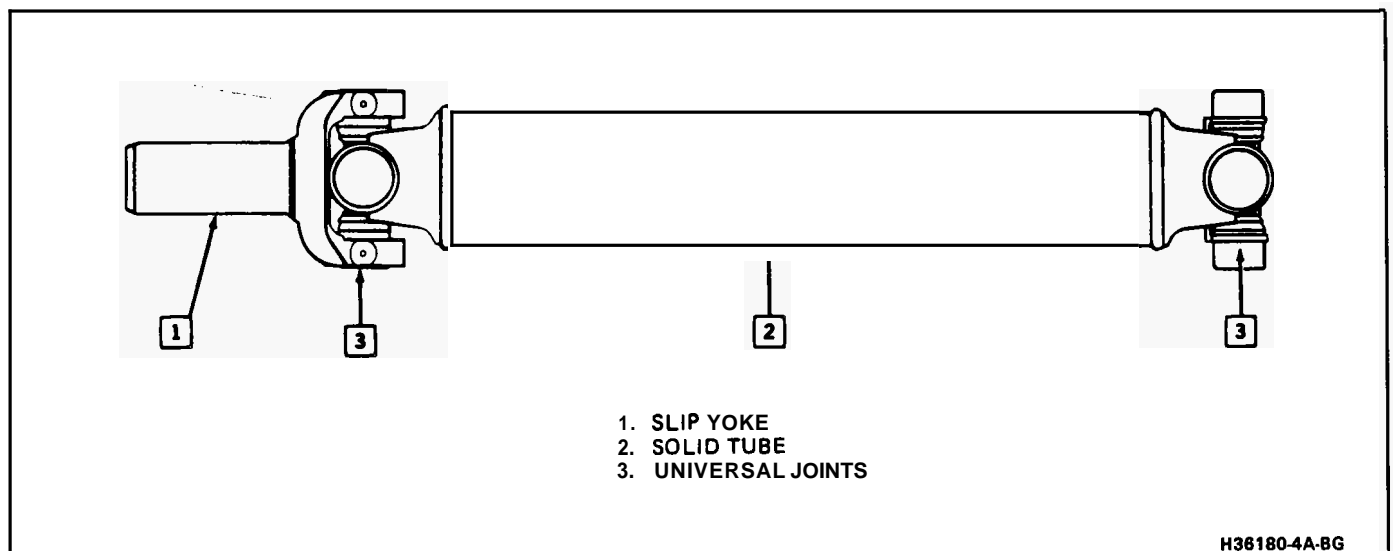

Figure 1 Propeller Shaft

DIAGNOSIS

PROPELLER SHAFT TROUBLE DIAGNOSIS

Condition	Possible Cause	Correction
Leak at front slip yoke. (An occasional drop of lubricant leaking from slip yoke is normal and requires no attention.)	<ol style="list-style-type: none"> 1. Rough outside surface on slip yoke. 2. Faulty transmission rear oil seal. 	<ol style="list-style-type: none"> 1. Replace seal if cut by burrs on yoke. Minor burrs can be smoothed by careful use of crocus cloth or honing with a fine stone. Replace yoke if outside surface is rough or burred badly. 2. Replace transmission rear oil seal. 3. Bring transmission oil up to proper level after correction.
Knock in drive line clunking noise when car is operated under float condition at 10 mph in high gear or "Neutral".	<ol style="list-style-type: none"> 1. Worn or damaged universal joints. 2. Side gear hub counter-bore in differential worn oversize. 	<ol style="list-style-type: none"> 1. Replace. 2. Replace differential case and/or side gears as required.
Ping, snap, or click in drive line.	<ol style="list-style-type: none"> 1. Loose upper or lower control arm bushing bolts. 2. Worn or damaged universal joints. 	<ol style="list-style-type: none"> 1. Tighten bolts to specified torque. 2. Replace.
Scraping noise.	Slinger rubbing on rear axle carrier.	Straighten slinger to remove interference.

Objectional vibration, roughness, rumble or boom can be caused by the input from a number of systems. The chart provides a systematic approach to finding the problem.

See Figure 2

To determine whether the propeller shaft is causing the problem, drive car through speed range and note speed (car and/or engine) at which problem is most pronounced (tachometer may be used). Shift transmission into a lower gear range and drive car at same engine speed as when problem was most pronounced in direct drive. Note effect on problem.

To determine engine speed, if tachometer is not used, divide car speed by the transmission gear ratio in which the problem occurs.

Example: With the 200C automatic transmission in 2 range, divide by **1.57**. If problem is most pronounced in direct drive at 81 Km/h (**55** mph) the same engine speed would be produced in 2 range at $55/1.57=35$ mph (58 Km/h).

If the problem is still present at the same engine speed whether in direct drive or in the lower gear range, since the propeller shaft speed varies, it cannot be at fault. If problem decreases or is eliminated, in a different gear range but at the same engine speed, check the possible causes in "Trouble Diagnosis Chart."

ON-CAR SERVICE

CHECKING UNIVERSAL JOINT ANGLE

See Figures 3 and 4

When torque is transmitted through any ordinary universal joint, the driven yoke fluctuates slightly in speed. In other words, although the slip yoke rotates at a constant speed, the pinion yoke speeds up and slows down twice per revolution. This fluctuation of the pinion yoke is in direct proportion to the angle through which the universal joint is operating; the greater the angle, the greater the fluctuation.

Whenever two universal joints are used, this fluctuation effect can be eliminated by staggering the joints so that the two yokes are 90° apart provided the

PROPELLER SHAFT DIAGNOSIS VIBRATION, ROUGHNESS, RUMBLE AND/OR BOOM

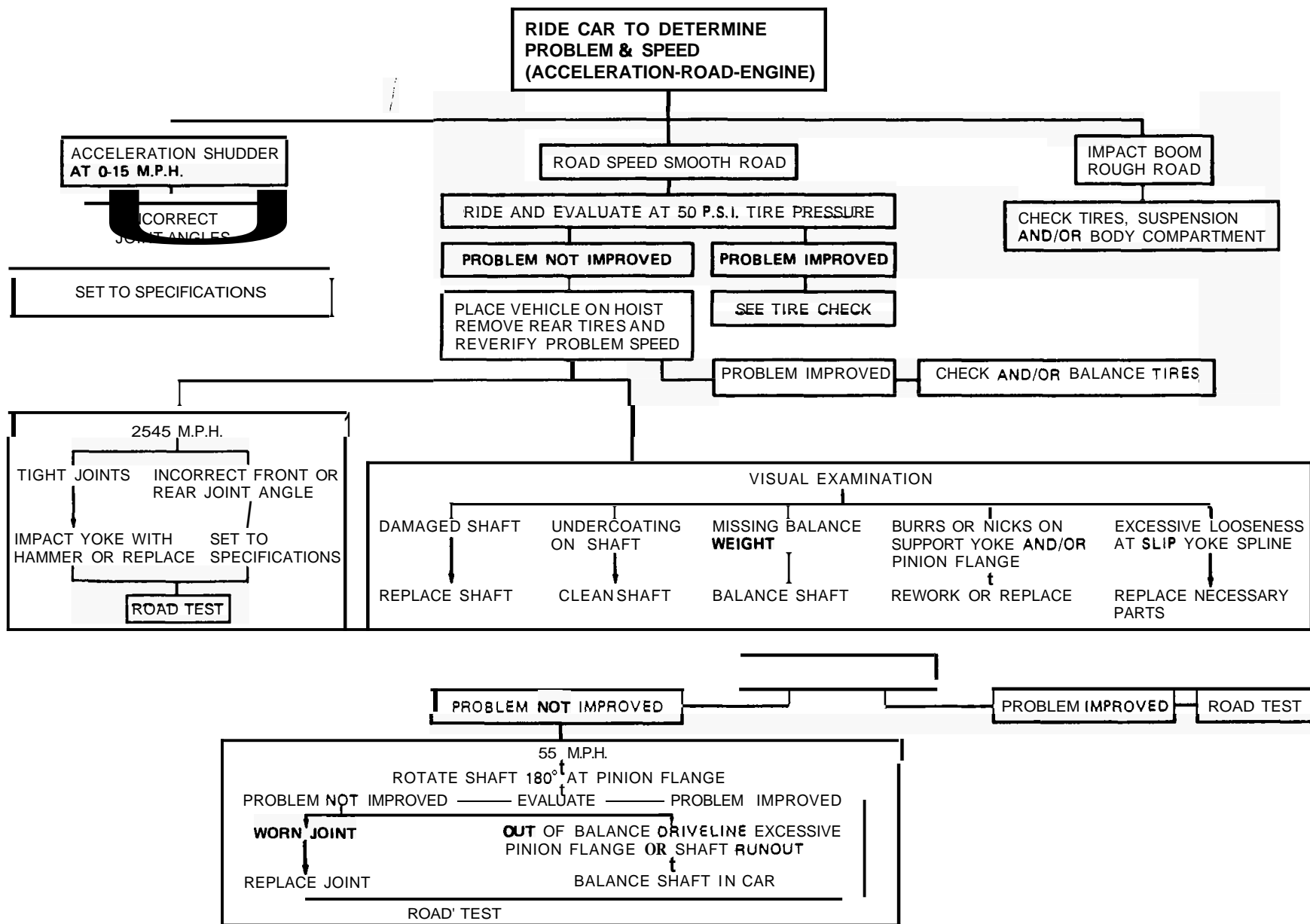

FIGURE 7-1100000-1000000-1000000

4A-4 PROPELLER SHAFT

two joints are transmitting torque through the same angle.

Therefore, when two universal joints are used, the angles through which they operate must be very nearly the same. This allows the alternate acceleration and deceleration of one joint to be offset by the alternate deceleration and acceleration of the second joint. When the two joints do not run at approximately the same angle, operation is rough and an objectionable vibration is produced.

The actual optimum angles desired must also consider the effects of various passenger loads and rear axle windup during acceleration so that it is unlikely that the front and rear joints will be found to be the same in actual practice.

If the designed angle is exceeded, the joint may be broken or otherwise damaged.

The front universal joint angle is actually the angle between the engine-transmission centerline and the propeller shaft. This angle is determined by the design of the frame assembly and may be altered by adding or removing shims between the transmission rear bearing retainer and the transmission mount.

On B and G carlines, $\pm 1^\circ$ rear joint angle corrections can be made by loosening all of the rear suspension control arm bolts and repositioning the pinion nose up or down. This takes advantage of all the bolt hole tolerances in the brackets.

Adding one shim at the transmission mount will decrease the transmission joint angle by $1/2^\circ$ and increase differential joint angle by $1/4^\circ$. If one shim is removed the transmission angle will increase $1/2^\circ$ and decrease differential angle $1/4^\circ$. The production transmission mount bolt is an M10 x 1.5 x 35 mm, when installing two or more shims, an M10 x 1.5 x 50 mm bolt must be used.

On B and G carlines, $\pm 1.5^\circ$ on G carline, $\pm 2^\circ$ on B carline rear joint angle corrections can be made by using control arms available for service.

All complaints of propeller vibration should be accompanied by rear trim height measurements at curb weight, see Section 3. An incorrect trim height may cause some vibration. If vibration is severe enough, removal or installation of spring shims may be required. If any irregular roughness or vibration is detectable in the drive line, the universal joint angles should be checked. Also, if a car is involved in a severe rear end collision, or if the rear axle housing is replaced, the rear universal joint angle should be checked and arms replaced if necessary.

Inclinometer Method

See Figures 5 through 9

Tools Required:

J 23498 Drive Shaft Inclinometer

J 23498-20 Adapter

This method can be used with the car over a pit or on a drive-on platform hoist as long as the car is at curb weight with a full tank of gasoline. Jounce car up and down to assure proper trim height. Before universal joint angles can be checked, the measurements specified for the distance between the top of the axle tube and the bottom of the frame must

	FRONT	REAR
G SERIES	$1/2^\circ$	1°
B SERIES WITH 7.5" AXLE	$1 1/4^\circ$	$2 1/2^\circ$
B SERIES WITH 8.5" AXLE	$1 1/4^\circ$	2
• THE ABOVE ANGLES MAY BE $\pm 1/20$		

Figure 3 Universal Joint Angles

SERIES	FRONT ANGLE CHANGE		REAR ANGLE CHANGE	
	B	G	B	G
+ SERVICE ARM (SHORT)	$+1/3^\circ$	$+1/3^\circ$	$+2^\circ$	$+1 1/4^\circ$
- SERVICE ARM (LONG)	$-1/3^\circ$	$-1/10^\circ$	-20	$-1 1/4^\circ$

be met. Weight may have to be added to the car to reach these specifications, but this must be done to insure an accurate measurement.

Angle at Rear Universal Joint

1. Place inclinometer J 23498 on rear propeller shaft universal joint bearing cap. Center bubble in sight glass and record measurement. Bearing cap must be straight up and down and free of dirt or other foreign material to obtain an accurate measurement.
2. Rotate propeller shaft 90° and place inclinometer on pinion yoke bearing cap. Center bubble in sight glass and record measurement.
3. Subtract smaller figure from larger figure to obtain existing rear universal joint angle.

Angle at Front Universal Joint

1. Place inclinometer on front propeller shaft bearing cap, center bubble in sight glass and record measurement.
2. Rotate propeller shaft 90° and place inclinometer on slip yoke bearing cap, center bubble in sight glass and record measurement.
3. Subtract smaller figure from larger figure to obtain existing front universal joint angle.

CHECKING PROPELLER SHAFT RUNOUT

See Figures 10 through 12

If a noise or vibration is present at high speed which might be caused by a bent shaft, or if a shaft has

AXLE TUBE TO FRAME HEIGHT			
SERIES		MEASUREMENT	
		MM	INCH
G SERIES COUPE		126	5
G SERIES SEDAN		121	4 3/4
B SERIES WITH 7.5" AXLE		160	6 1/4
B SERIES WITH 8.5" AXLE		166	6 5/8
ALL MEASUREMENTS ARE $\pm 1/4$ "			

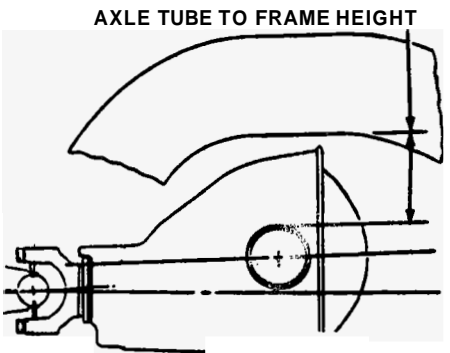

H35956-4A-BG

Figure 5 Axle Tube to Frame Height

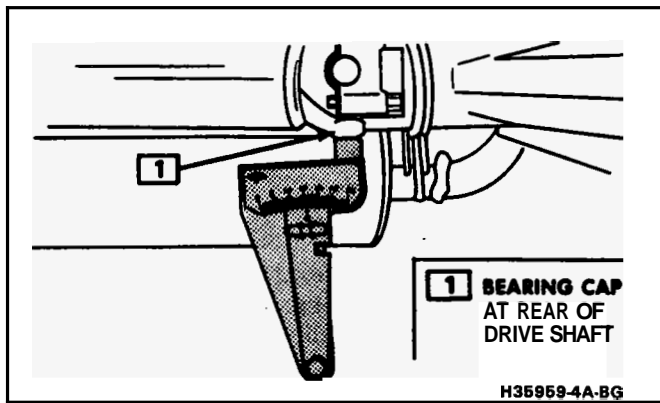

Figure 6 Measuring Angle at Rear of Propeller Shaft

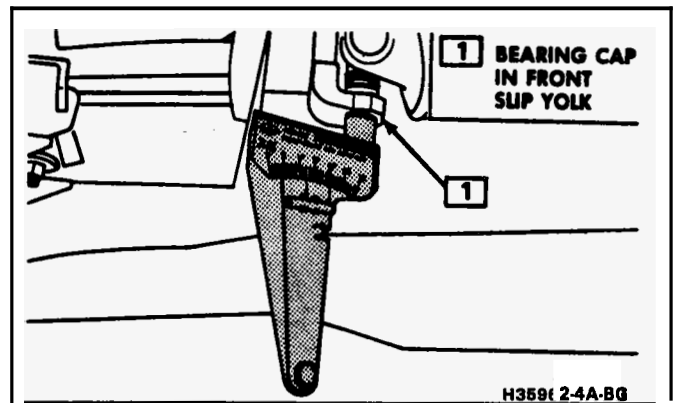

Figure 9 Measuring Angle at Slip Yoke

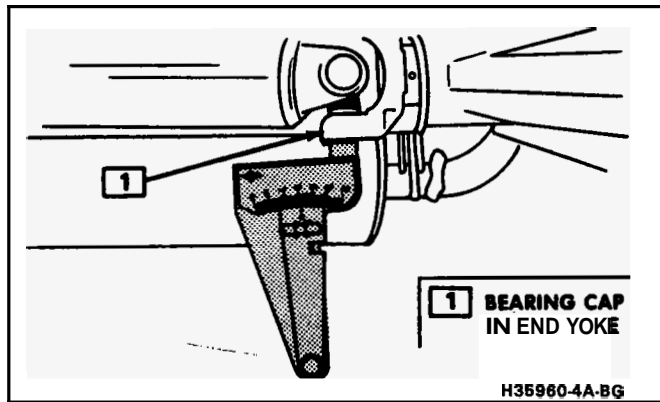

Figure 7 Measuring Angle at Front of Pinion Yoke

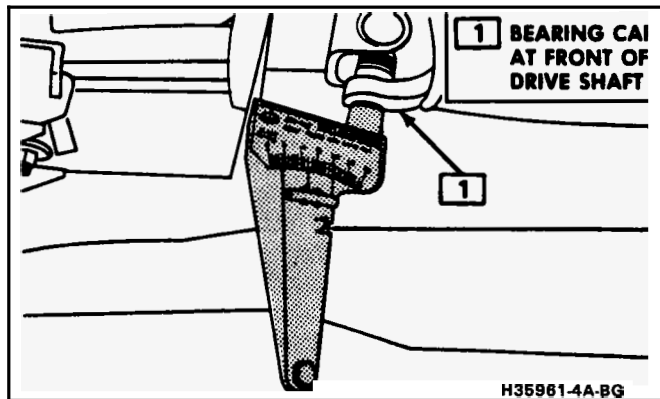

Figure 8 Measuring Angle at Front of Propeller Shaft

been damaged through rough handling or a collision, it may be checked for straightness as follows:

1. Raise car on a twin post hoist so that the rear is supported on the rear axle housing with wheels free to rotate.
2. Mount a dial indicator on a movable support that is high enough to permit contact of the indicator button with the propeller shaft, or mount dial indicator to a magnetic base and attach to a suitable smooth place on the underbody of the car. Readings are to be taken at points indicated.
3. With transmission in "Neutral", check for runout by turning a rear wheel so the propeller shaft will rotate.

! Important

- For B and G carlines there are two different propeller shafts used. Specifications for runout are different on the two shafts. Care must be taken not to include indicator variation caused by ridges, flat spots or other variations in the tube.
4. If runout exceeds specifications, rotate the shaft 180" at pinion yoke and reinstall. Check runout again.
 5. If runout is still over specifications at the pinion yoke end, pinion yoke runout should be measured. If runout is still over specifications, replace the propeller shaft, but only after checking for vibration or noise.

4A-6 PROPELLER SHAFT

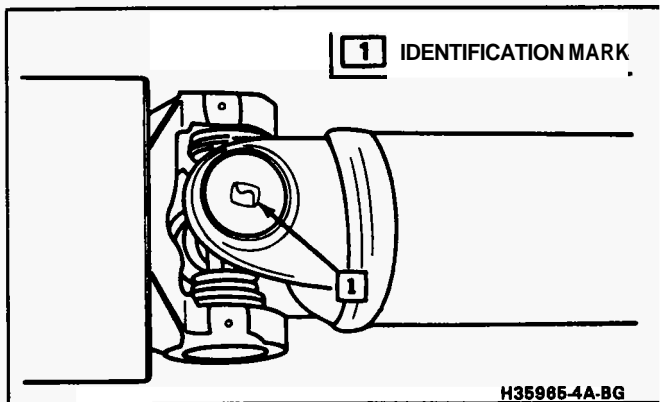
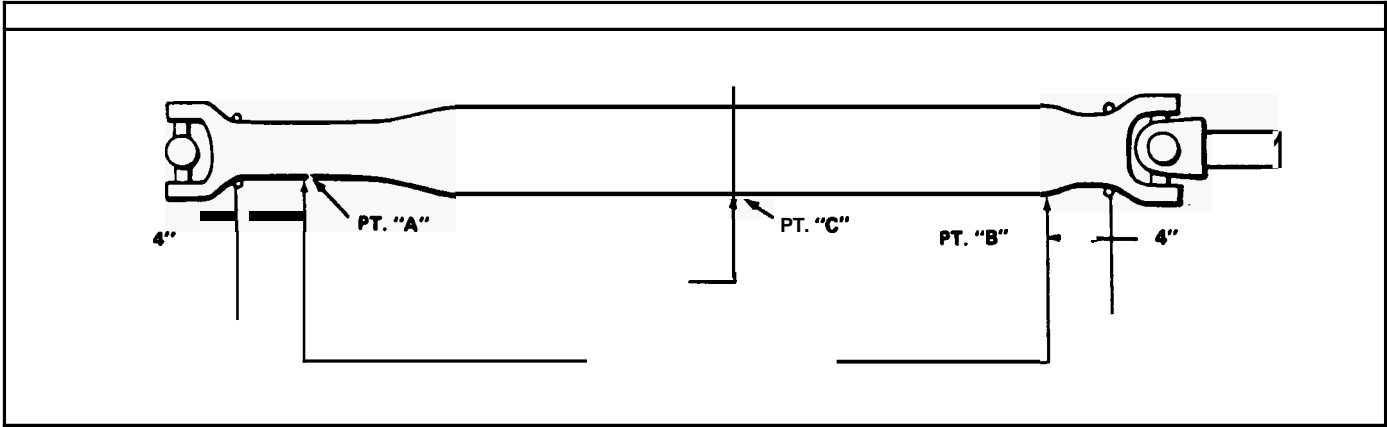

Figure 11 Propeller Shaft Identification Mark

SERIES	FRONT	CENTER	REAR
B + G	.040	.040	.040
* B + G	.024	—	.024

*PROPELLER SHAFTS WITH IDENTIFICATION MARKINGS ON UNIVERSAL JOINT BEARING CAPS.

H35984-4A-BG

Figure 12 Runout Specifications

PINION YOKE RUNOUT

See Figure 13

Tools Required:

- J 35819 Runout Gage
- J 8001 Dial Indicator

Measure

Check pinion yoke runout using J 35819 and J 8001 or equivalent. Record runout and mark high and low points of pinion yoke.

- A. If pinion yoke runout is 0.15 mm (.006") or less, remove pinion yoke balance weight, if used. No further action is required.
- B. If pinion yoke runout is over 0.15 mm (.006"), but less than 0.28 mm (.011") and balance weight is

at or near low point of pinion yoke runout, no further action is required.

If balance weight is not at or near low point of pinion yoke runout, remove weight.

- C. If pinion yoke runout is over 0.28 mm (.011"), but no greater than 0.38 mm (.015") and balance weight is at or near low point of pinion yoke runout, no further action is required.

If balance weight is not at or near low point of pinion yoke runout, remove weight and reindex pinion yoke until runout is 0.25 mm (.010") or less.

If impossible to achieve 0.25 mm (.010") or less runout, install a new pinion yoke and recheck for 0.25 mm (.010") or less runout.

Service replacement pinion yokes are not equipped with balance weights and no weights should be added.

PROPELLER SHAFT BALANCING PROCEDURE

Hose Clamp Method

See Figures 14 through 16

1. Place the car on a twin post hoist so that the rear of the car is supported on the rear axle housing and the rear wheels are free to rotate. Remove both rear tire and wheel assemblies and reinstall wheel nuts with flat side next to drum.
2. Mark and number propeller shaft at four (4) points 90° apart at rear of shaft just forward of balance weight.
3. Install two (2) hose clamps on the rear of the propeller shaft and slide them rearward until the clamps stop at the nearest balance weight welded to the tube. Align both clamps to any one of the four marks made on shaft in Step 2 and tighten the clamps. Be sure sufficient clearance is maintained so that clamp heads do not contact floor pan of car when axle is in contact with rebound bumper in frame. In order to gain sufficient clearance, it may be necessary to position the clamps over the balance weights.
4. Run the car through the speed range to 50-55 mph (81-89 Km/h). Note amount of imbalance.

CAUTION: Never run car faster than 55 mph (89 Km/h). Also all personnel should stay clear of driveline joint and

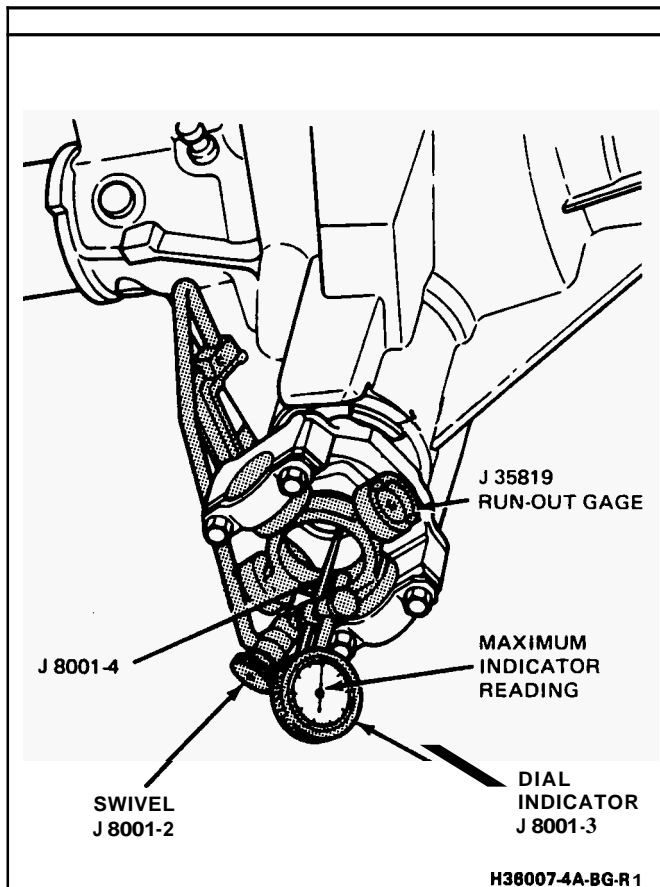

Figure 13 Pinion Yoke Runout

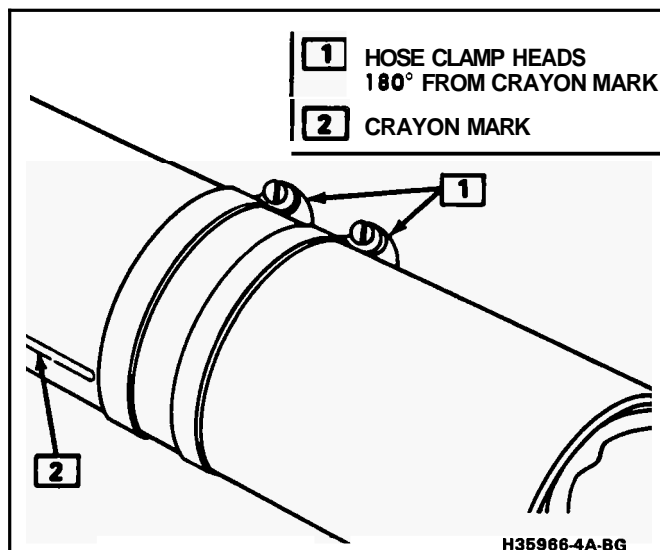

Figure 14 Balance Hose Clamps in Place

balance weight area to avoid possible injury. Do not run car on hoist for extended periods due to danger of overheating the transmission or engine.

5. Loosen clamps and rotate clamp heads 90° to the next mark on shaft. Tighten clamps and repeat Step 4.
6. Repeat Step 5 until car has been run with clamp heads located at all four marks on shaft.
7. Position clamps at point of minimum imbalance. Rotate the clamp heads away from each other

45°. (One each way from the point of minimum unbalance). Run the car and note if unbalance has improved.

In some cases it may be necessary to use one clamp or possibly three clamps in order to obtain a good balance.

Replace shaft if three hose clamps do not improve the imbalance.

8. Continue to rotate the clamps apart in smaller angular increments until the feel for imbalance is best.
9. Reinstall tire and wheel assemblies and road test the car for final check of balance. Vibration felt in the car on the hoist may not show up in a road test, which is the final determining factor.

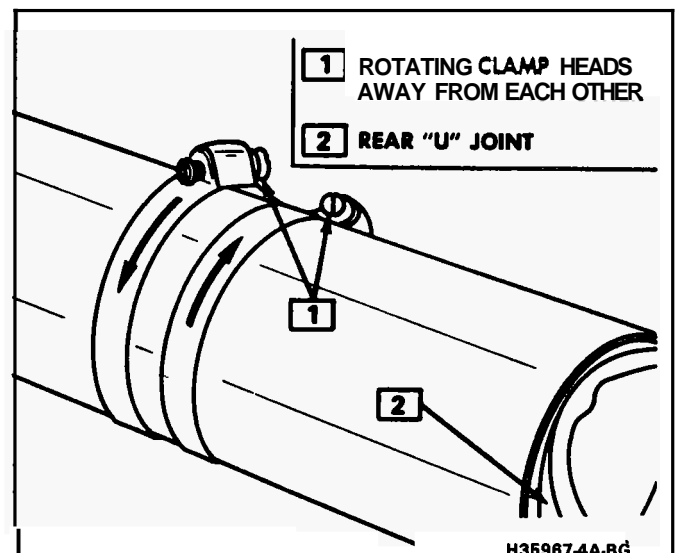

Figure 15 Rotating Balance Hose Clamps

Strobe Light Method

See Figures 15 through 18

If a wheel balancer of the type that is equipped with a strobe light is available, the use of such a unit will facilitate the balancing of the propeller shaft. The balance pick-up unit should be placed directly under the pinion yoke in contact with rear axle housing and as far forward as possible.

1. Place the car on a twin post hoist so that the rear of the car is supported on the rear axle housing and the rear wheels are free to rotate. Lower rear post hoist and allow axle tube to rest on axle stands. The groove of the rear post hoist could clamp the axle and destroy the sensitivity of the operation. Remove both rear tire and wheel assemblies and reinstall wheel nuts with flat side next to drum.
2. Mark and number propeller shaft at 4 points 90° apart at rear of shaft just forward of balance weights.
3. Place strobe light wheel balancer pick-up under the pinion yoke in contact with the rear axle housing and as far forward as possible.
4. With car running in gear at car speed where disturbance is at its peak, allow the driveline to stabilize by holding at constant speed. Point

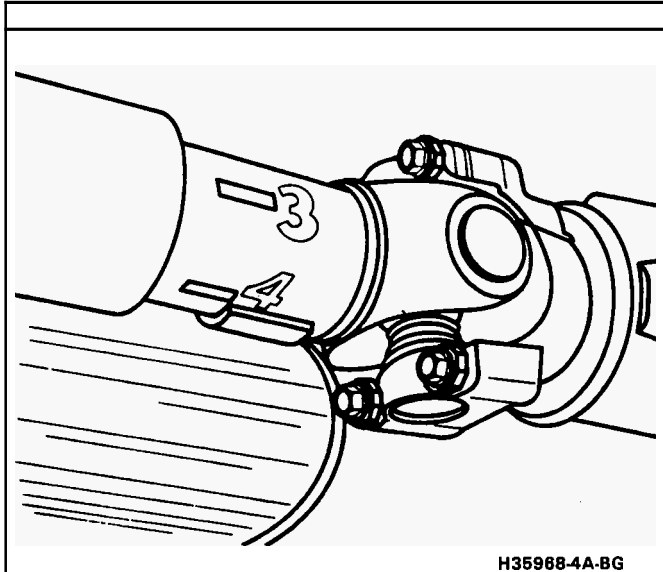

Figure 16 Reference Marks on Propeller Shaft

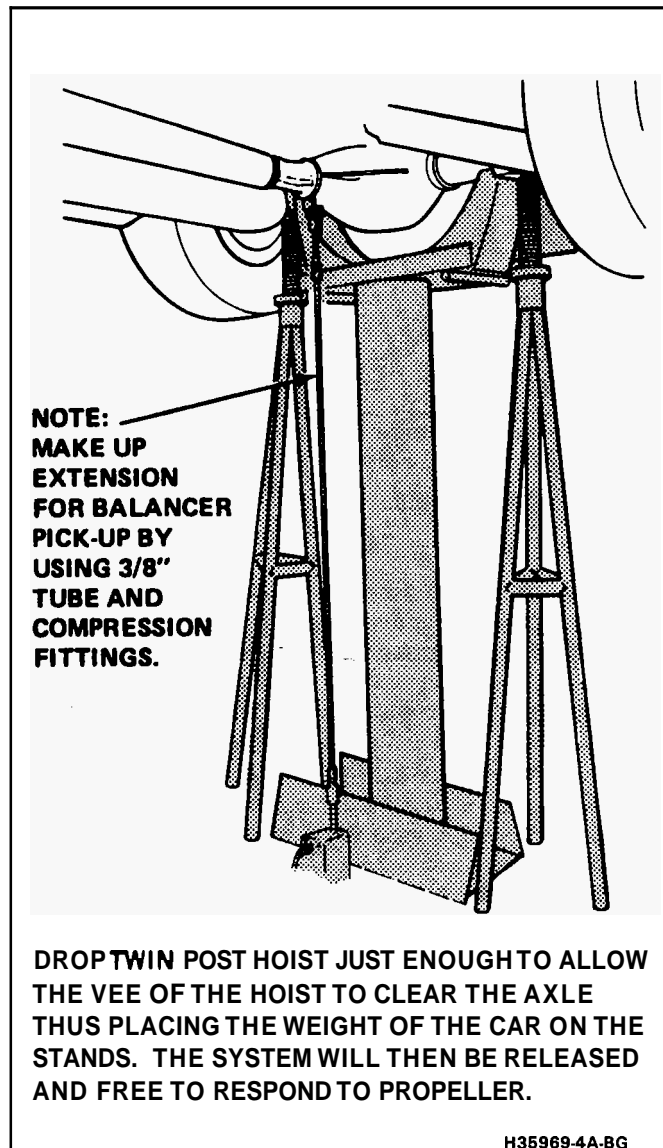

Figure 17 Pick-Up Unit at Differential Pinion Nose

strobe light up at the spinning shaft and note position of one of these reference numbers. Shut off engine and position the propeller shaft so that

the reference numbers will be in the same position as was noted with strobe while the shaft was rotating.

When strobe light flashed, the heaviest point of the shaft was down (6 o'clock) and to balance this shaft, it will be necessary to apply the balancing weight 180° away from the heaviest point or at the top of the shaft (12 o'clock).

5. Install two screw-type hose clamps on the propeller shaft as close to the rear as possible. Position both clamp heads 180° from the heaviest point of propeller shaft as indicated by strobe light and tighten clamps.
6. Run car through the speed range to 50-55 mph (81-89 Km/h). If disturbance is gone, nothing further need be done on the hoist. If the disturbance is not gone and the strobe light shows the clamp heads at the bottom (6 o'clock) of the shaft, go to Step 7. If the strobe light shows the two clamp heads at the top of the shaft, add one more hose clamp and recheck. If the strobe light shows the three clamp heads at the top of the shaft, remove the shaft and reinstall it 180° on the pinion yoke. Recheck balance with no clamps. Repeat balance procedure starting with Step 5. If the shaft still needs more than three hose clamps for proper balance, replace the shaft. However, if the clamps are also 180° from their original position after the shaft was rotated 180°, the pinion yoke on the axle is out of balance and must be replaced. **DO NOT** use more than three hose clamps to balance the shaft. If the strobe light shows the hose clamps at the bottom of the shaft, but the disturbance still exists, go to Step 7.

CAUTION: Never run car faster than 55 mph (89 Km/h). Also all personnel should stay clear of driveline joint and balance weight area to avoid possible injury. Do not run car on hoist for extended periods due to danger of overheating the transmission or engine.

7. Rotate two of the hose clamps equally away from each other toward the top in small increments until best balance is achieved.
In some cases it may be necessary to use one clamp or possibly three clamps in order to obtain a good balance.
Replace shaft if three hose clamps do not correct problem.
8. Install rear drums and wheels and road test car for final check of balance.
Vibration felt in the car on the hoist may not show up in a road test, which is the final determining factor.

PROPELLER SHAFT

Remove or Disconnect

NOTICE: Do not strike or drop propeller shaft, or allow universal joints to bend to extreme angles, as this might fracture a joint internally.

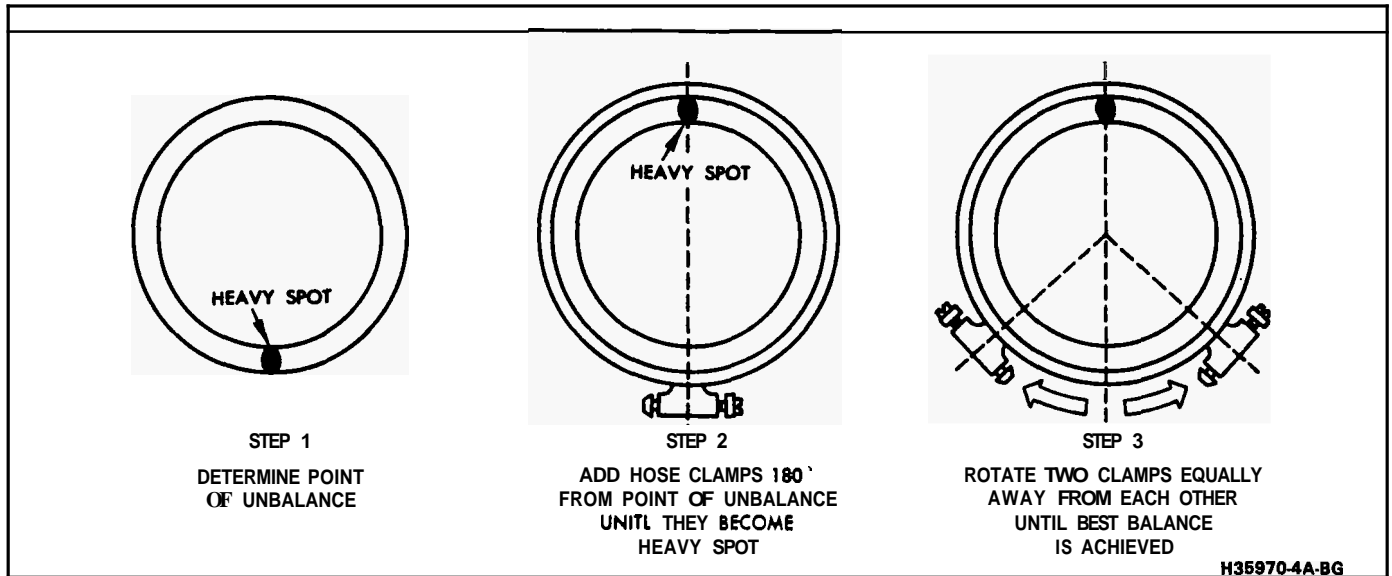

Figure 18 Positioning Hose Clamp to Achieve Best Balance

1. Raise and suitably support car. See Section OA.
2. Mark relationship of propeller shaft to rear axle pinion yoke.
3. Propeller shaft retaining bolts
4. Retaining straps
5. Propeller shaft by withdrawing slip yoke from transmission, moving shaft rearward, passing it under the rear axle housing
 - o Support propeller shaft during removal.
 - o If bearing cups are loose, tape together to prevent dropping and loss of bearing rollers.

inspect

- Transmission output shaft splines for burrs
- o Outer diameter of slip yoke for burrs
- o Splines of slip yoke for damage, twisting or wear
- o Pinion yoke at universal joint cup mating surface for burrs or foreign material

Install or Connect

The propeller shaft must be supported carefully during handling to avoid jamming or bending any of the parts.

1. Slip yoke onto transmission output shaft after lubricating surfaces with engine oil
2. Rear of propeller shaft to pinion yoke

Important

- o To prevent seal damage, do not place any tool between slip yoke and splines.
 - o When making rear shaft connection, be sure to align mark on pinion yoke with mark on propeller shaft.
3. Rear universal joint to pinion yoke, making sure bearing cups are properly seated
 4. Retaining straps
 5. Propeller shaft retaining bolts evenly to 20 N·m (15 lb. ft.)

UNIT REPAIR

UNIVERSAL JOINTS

See Figures 19 through 21

Tools Required:

- J 9522-3 Bearing Separator
- J 9522-5 Spacer Remover

important

- o Never clamp propeller shaft tubing.
- o Always clamp on one of the yokes and support the shaft horizontally.
- o Avoid damaging the slip yoke sealing surface.
- Burrs will damage the bushing or cut the lip seal.

Disassemble

When disassembling a propeller shaft, two types of universal joints may be found.

1. Support the propeller shaft in a horizontal position in line with the base plate of a press.
2. Place the universal joint so that the lower ear of the shaft yoke is supported on a 1 1/8" socket.
3. Place the universal joint bearing separator J 2522-3 on the open horizontal bearing cups, and press the lower bearing cup out of the yoke ear. This will shear the plastic retaining ring on the lower bearing cup. If the bearing cup is not completely removed, lift the bearing separator and insert J 9522-5 between the seal and the bearing cup. Complete removal of the bearing cup by pressing it out of the yoke.
4. Rotate the propeller shaft, shear the opposite plastic retainer, and press the opposite bearing cup out of the yoke.
 - o There are no bearing retainer grooves in production bearing cups, therefore, they cannot be reused.

- o If the front universal joint is being replaced, remove the bearing cup from the slip yoke in the same manner.
- o Complete the removal of the bearing cup by pressing it out of the yoke.

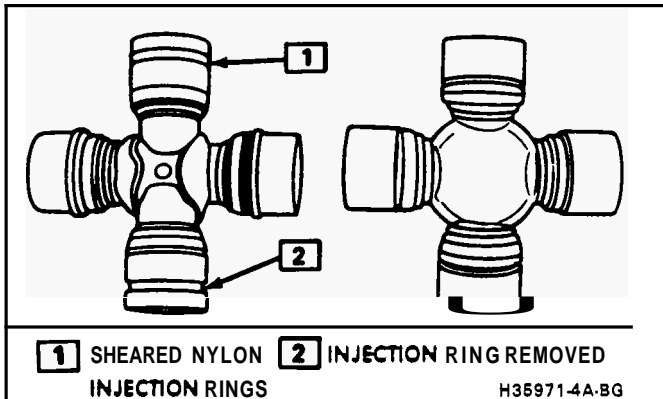

Figure 19 Production Universal Joints

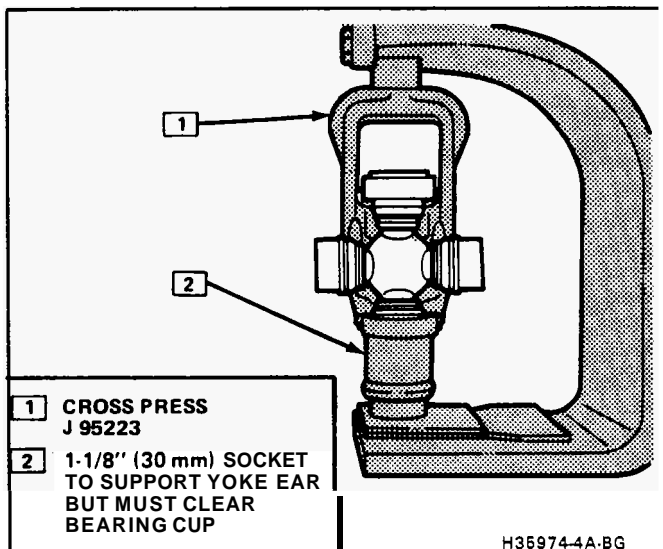

Figure 20 Pressing Out Universal Joint Bearing

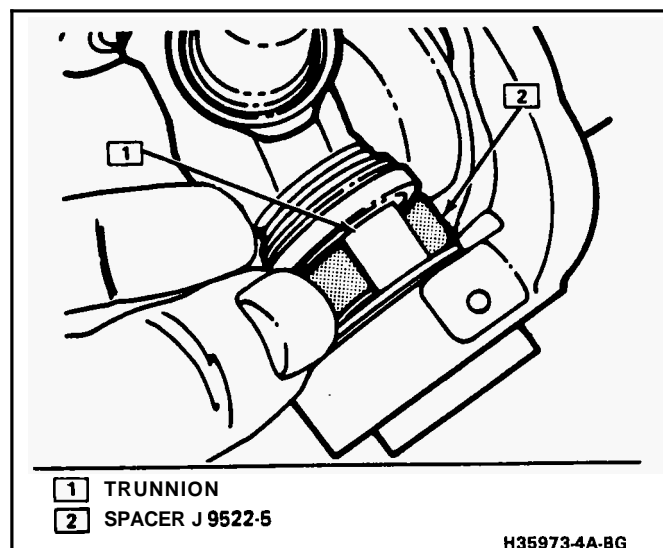

Figure 21 Using J 9522-5 Spacer

Clean

- o Yoke in area locating snap ring to insure proper assembly
- o All sheared plastic from universal joint cup bore

Assemble

See Figures 22 through 25

When reassembling a propeller shaft, always install a complete universal joint service kit. This kit includes one (1) pregreased cross assembly, four (4) service bearing cup assemblies with seals, needle rollers, washers, and grease; and four (4) bearing retainers. Make sure that the seals are in place on the service bearing cups to hold the needle rollers in place for handling.

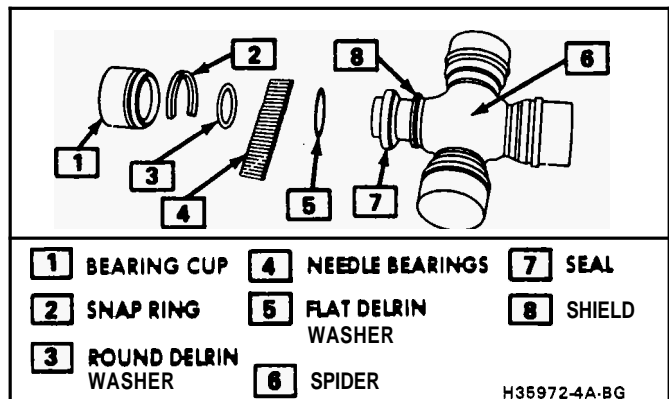

Figure 22 Service Universal Joint

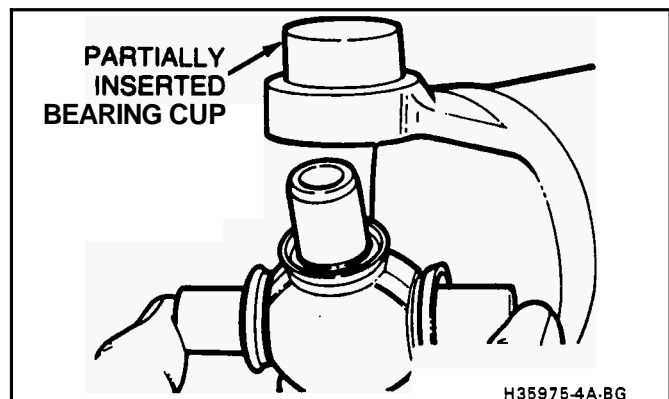

Figure 23 Partially Inserted Bearing Cup

1. Install one (1) bearing cup part way into one side of the yoke, and turn this yoke ear to the bottom.
2. Insert J 9522-3 so that the trunnion seats freely into bearing cup.
3. Install opposite bearing cup part way. Make sure that both trunnions are started straight and true into both bearing cups.
4. Press against opposite bearing cups, working the cross all of the time to insure free movement of the trunnions in the bearings. If there seems to be binding, stop pressing and recheck needle rollers because one or more of them has probably been tipped under the end of the trunnion.

5. As soon as one bearing retainer groove clears the inside of the yoke, stop pressing and snap the bearing retainer into place.
6. Continue to press until the opposite bearing retainer can be snapped into place. If difficulty is

encountered, strike the yoke firmly with a hammer to aid in seating bearing retainers. This springs the yoke ears slightly.

7. The other half of the universal joint is installed in the same manner.

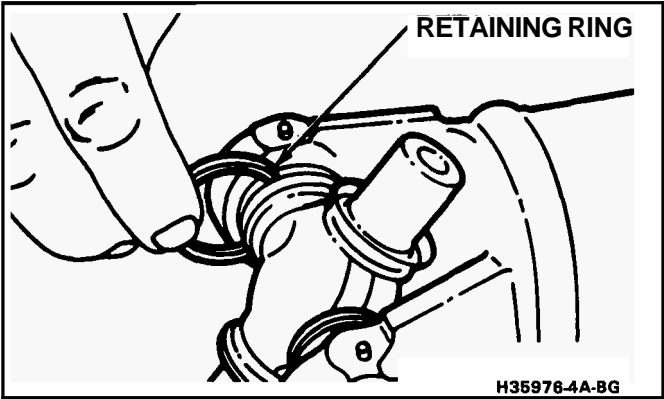

Figure 24 Installing Retaining Ring

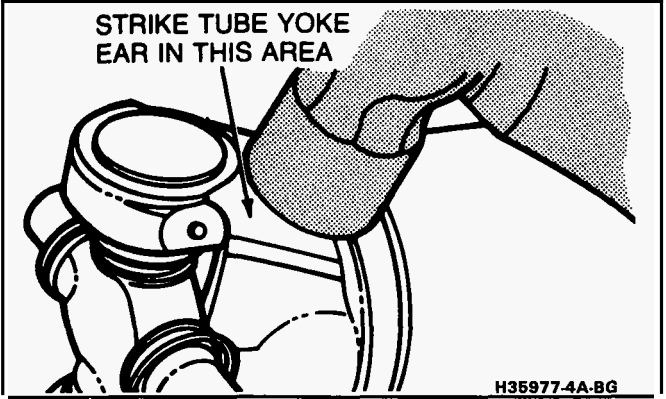

Figure 25 Seating U-Joint Retaining Ring

SPECIFICATIONS

TORQUE SPECIFICATIONS

Use a reliable torque wrench to tighten the parts listed to insure proper tightening without straining or distorting parts. These specifications are for clean and lightly-lubricated threads only; dry or dirty threads produce increased friction which prevents accurate measurement of tightness.

Part	Location	Thread Size	Torque N·m
Bolt	Rear Universal Joint to Pinion Yoke	5/16-24	20 N·m (15 Lbs. Ft.)

GENERAL SPECIFICATIONS

Propeller Shaft One Piece Open Drive Line
 Universal Joints Two Lifetime Sealed

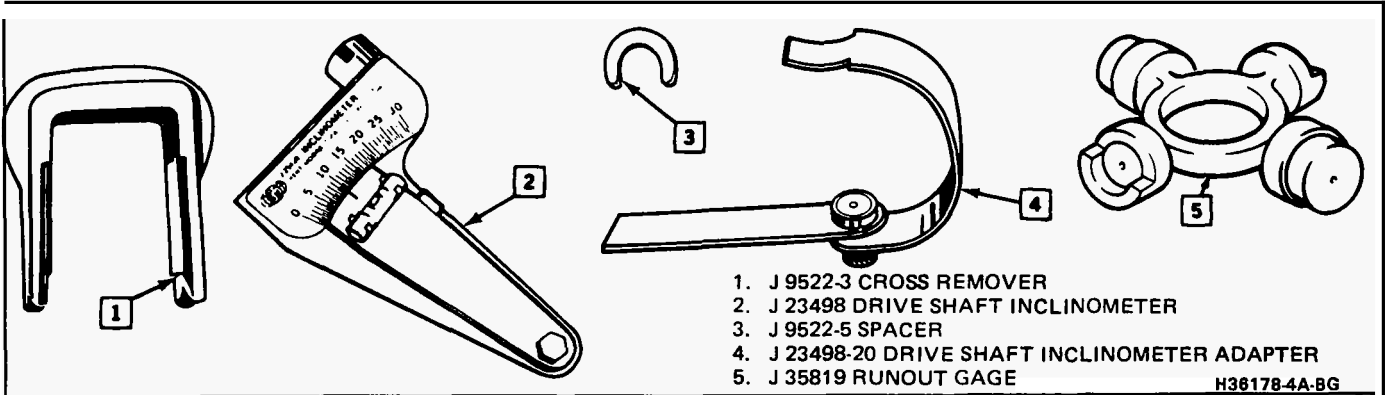

Figure 26 Special Tools

