

SECTION 2C

CHASSIS SHEET METAL

NOTICE: All Chassis Sheet Metal attaching fasteners are an important attaching part in that they could affect the performance of vital parts and systems, and/or could result in major repair expense. It must be replaced with one of the same part number or with an equivalent part if replacement becomes necessary. Do not use a replacement part of lesser quality of substitute design. Torque values must be used as specified during reassembly to assure proper retention of this part.

Anti-corrosion materials have been applied to the interior surfaces of some metal panels to provide rust resistance. When servicing these panels, areas on which this material has been disturbed should be properly recoated with service-type anti-corrosion material.

NOTICE: The theft deterrent label found on some major sheet metal, engines, and transmissions must be masked prior to painting, rustproofing, undercoating, etc. The mask **must** be removed following the above operations. Failure to keep the label clean and readable may result in liability for violation of Federal Vehicle Theft Prevention Standard, and subject the vehicle owner to possible suspicion that the part was stolen. For detailed information, see Section OA.

CONTENTS

| | | | |
|-------------------------------------|------|--|------|
| GENERAL DESCRIPTION: | | | |
| General Description | 2C-1 | Sheet Metal Alignment | 2C-2 |
| Fasteners | 2C-1 | ON CAR SERVICE: | |
| DIAGNOSIS: | | Assembly Illustrations | 2C-3 |
| Hood Noise or Flutter | 2C-1 | SPECIFICATIONS: | |
| MAINTENANCE AND ADJUSTMENTS: | | Tightening (Refer to Assembly Illustrations) | |

GENERAL DESCRIPTION

NON-METAL PANELS

Certain exterior body panels are made of a highly flexible, color coordinated, molded urethane. Since these panels are flexible they cannot be painted with acrylic lacquer.

Urethane paint is especially made with a flexible conditioner so that the cured film will flex without cracking.

FASTENERS

Many aluminum components are used in the sheet metal area. Aluminum in contact with steel may corrode rapidly if not protected by special finishes or isolators.

Many of the fasteners used in the front sheet metal area have the GM 6174M finish which will provide adequate protection. In some places, however, special fasteners are used in conjunction with aluminum components. These special fasteners are argent silver to identify them from the standard metric fasteners which are medium blue.

NOTICE: When replacing fasteners in the front sheet metal area, avoid substitution of otherwise similar fasteners in locations which should use GM 6174M type fasteners or special fasteners for aluminum components.

Failure to follow this precaution may result in premature corrosion of the sheet metal in the areas mentioned above.

DIAGNOSIS

HOOD NOISE OR PANEL FLUTTER

All Series

Squeaks or grunting noises in the hood when driving over rough roads do not necessarily indicate misalignment of hood or fenders. These noises may be caused by metal contact at some point where clearance should exist or by worn or dry hood bumpers.

If the hood squeaks, check for uniform clearance all around the hood and fenders. If an edge of metal is making contact at any point where clearance should exist, a bright metal spot will usually be found. Such spots may be depressed by spring hammering to provide clearance.

A grunting noise in the hood is usually caused by dry rubber bumpers on fender rails and cowl ledge lacing. Lubricate all rubber bumpers on fender rails and cowl with silicone rubber lubricant. To correct a persistent case of squeaking or grunting where hood to panel contacts ledge lacing, even when lubricated, cement a 1/16 inch thick strip of felt to panel where the lacing makes contact.

To prevent hood panel flutter, the rear end of the hood panel must have firm contact with the rubber bumpers and lacing attached to cowl ledge.

ON CAR SERVICE

SHEET METAL ALIGNMENT

Hood alignment can be adjusted by loosening the hood hinge to hood bolts, moving the hood fore or aft as required and then tightening the bolts.

Front fender alignment can be adjusted by loosening rear of fender securing bolts and front sheet metal mounts, then shifting fender location by adding or subtracting shims and retightening bolts. Refer to Figures 2C-1 and 2C-2 for alignment specifications.

Major front end sheet metal assembly illustrations begin with Figure 2C-3.

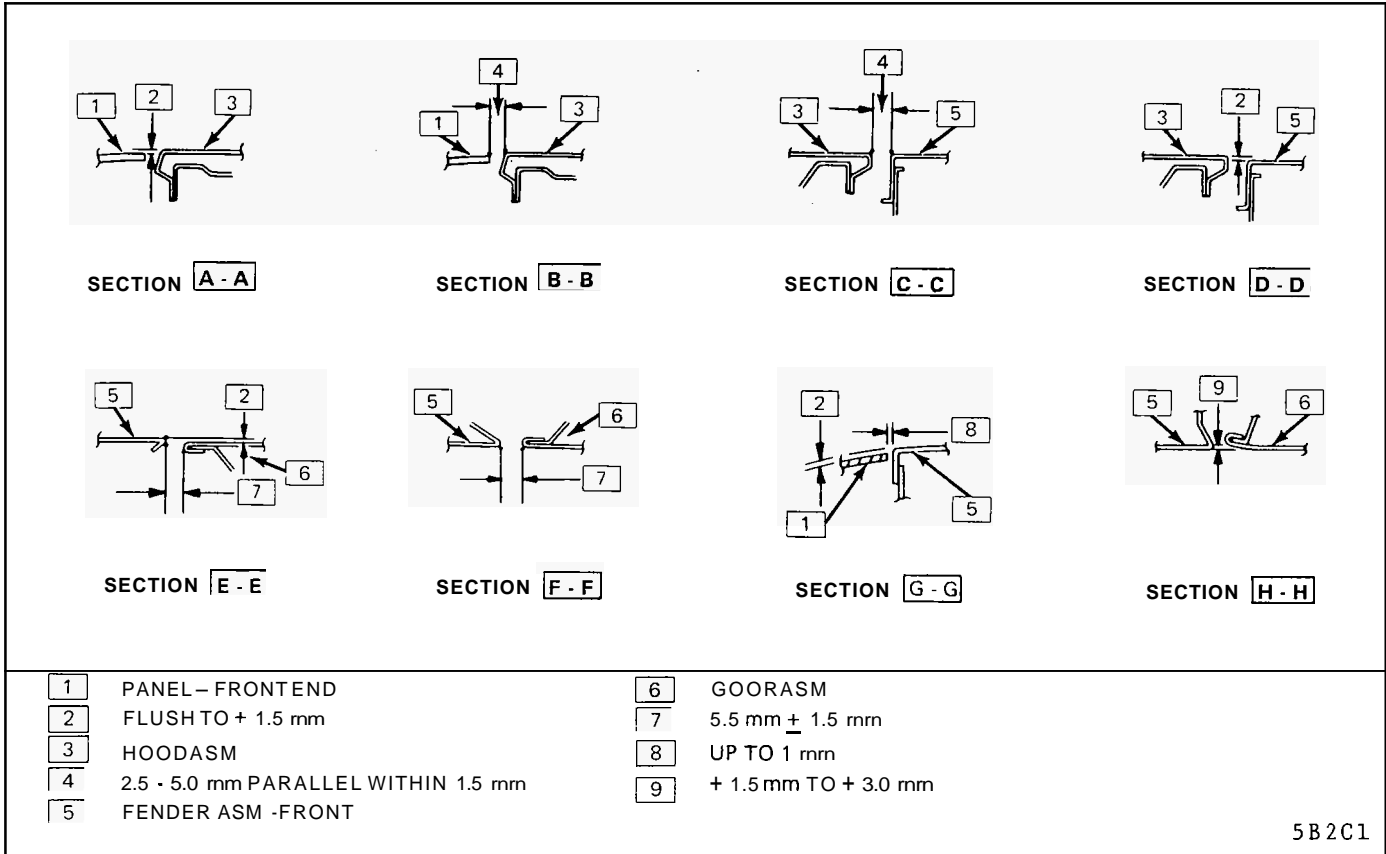

5B2C1

Figure 2C-1 Sheet Metal Alignment Specs (Except "C" & "H" Car)

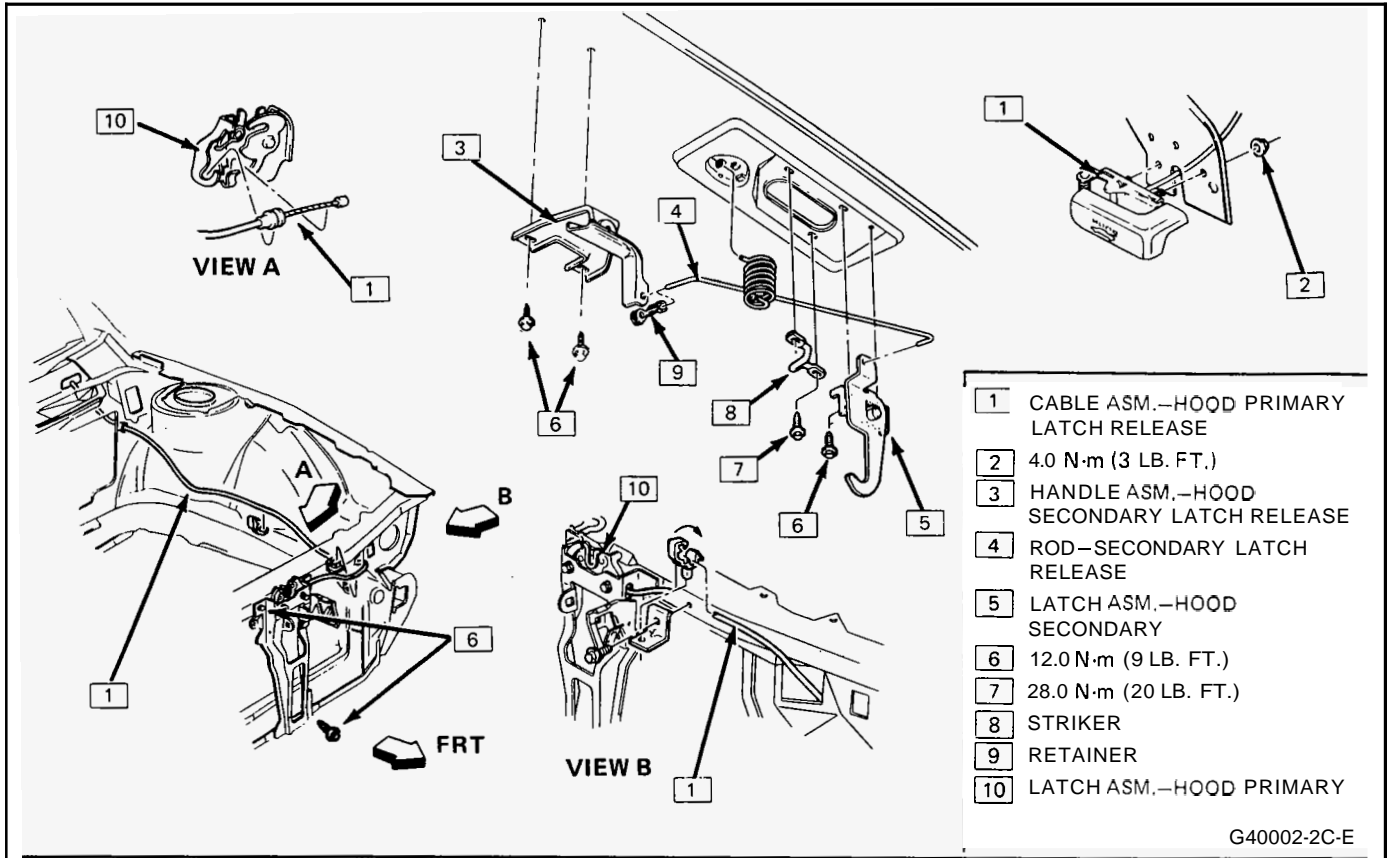

Figure 2C-10 Hood Release System ("E" Car)

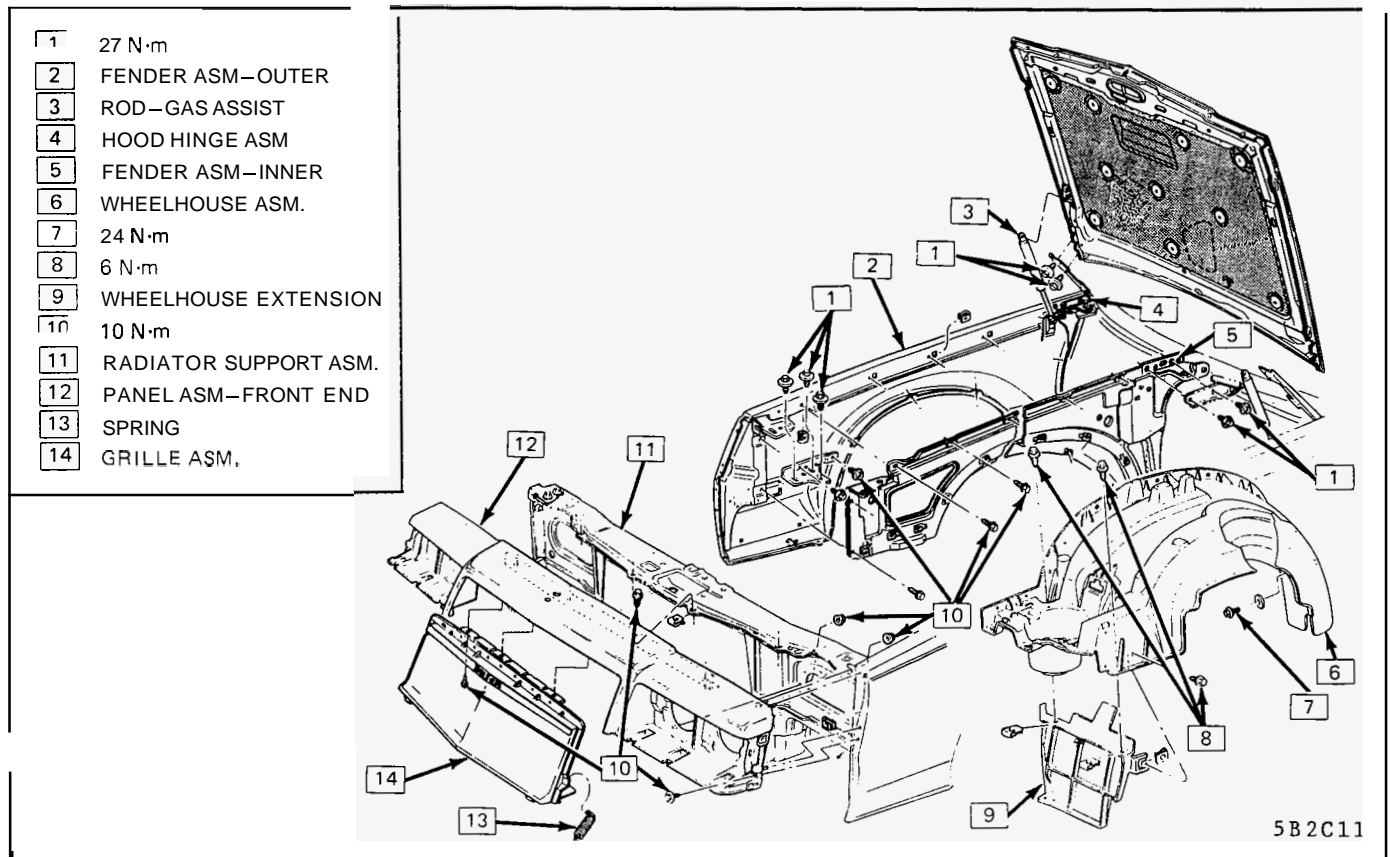

Figure 2C-11 Front End Sheet Metal ("G" Car)

2C-8 CHASSIS SHEET METAL

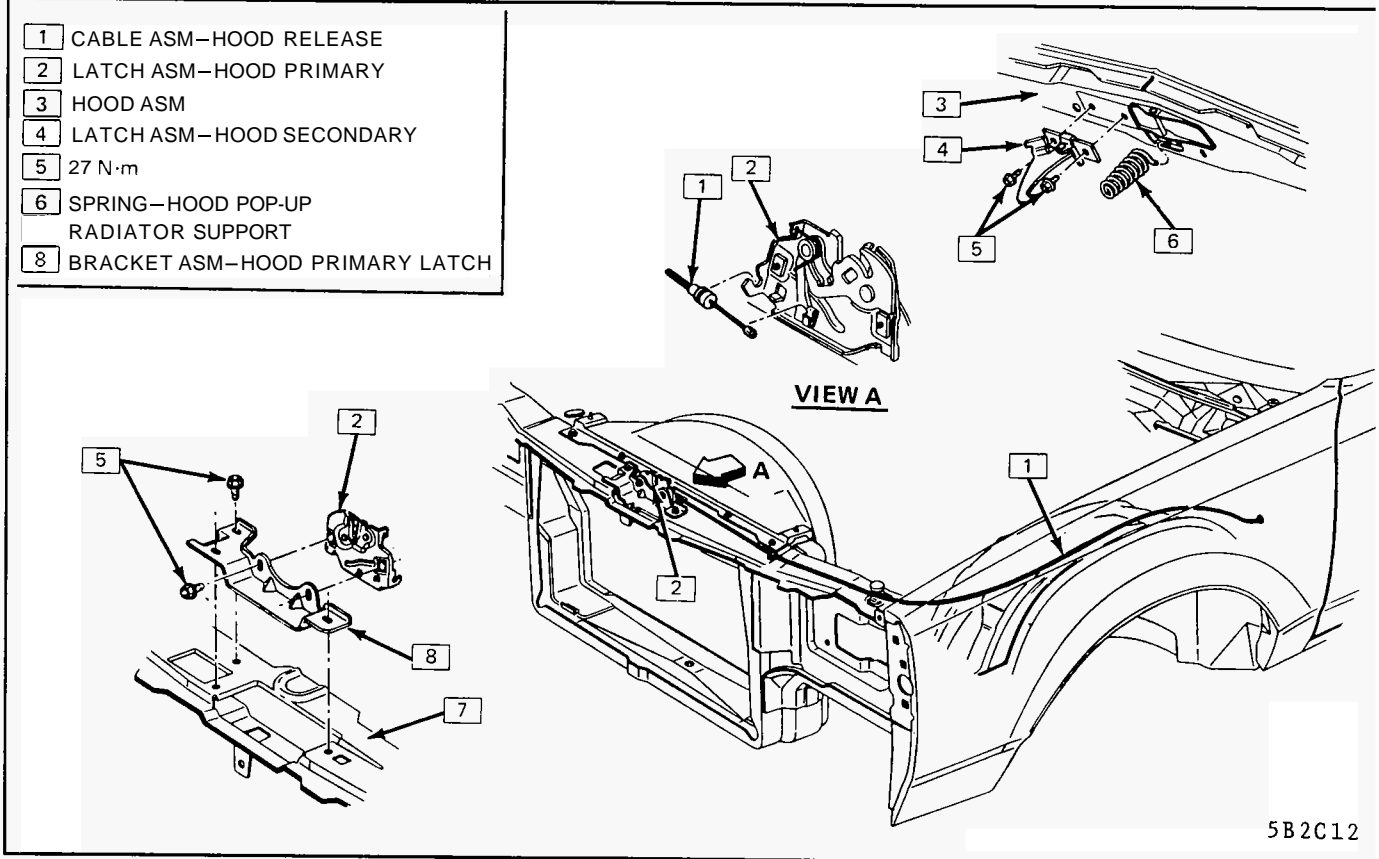

Figure 2C-12 Hood Release System ("G" Car)

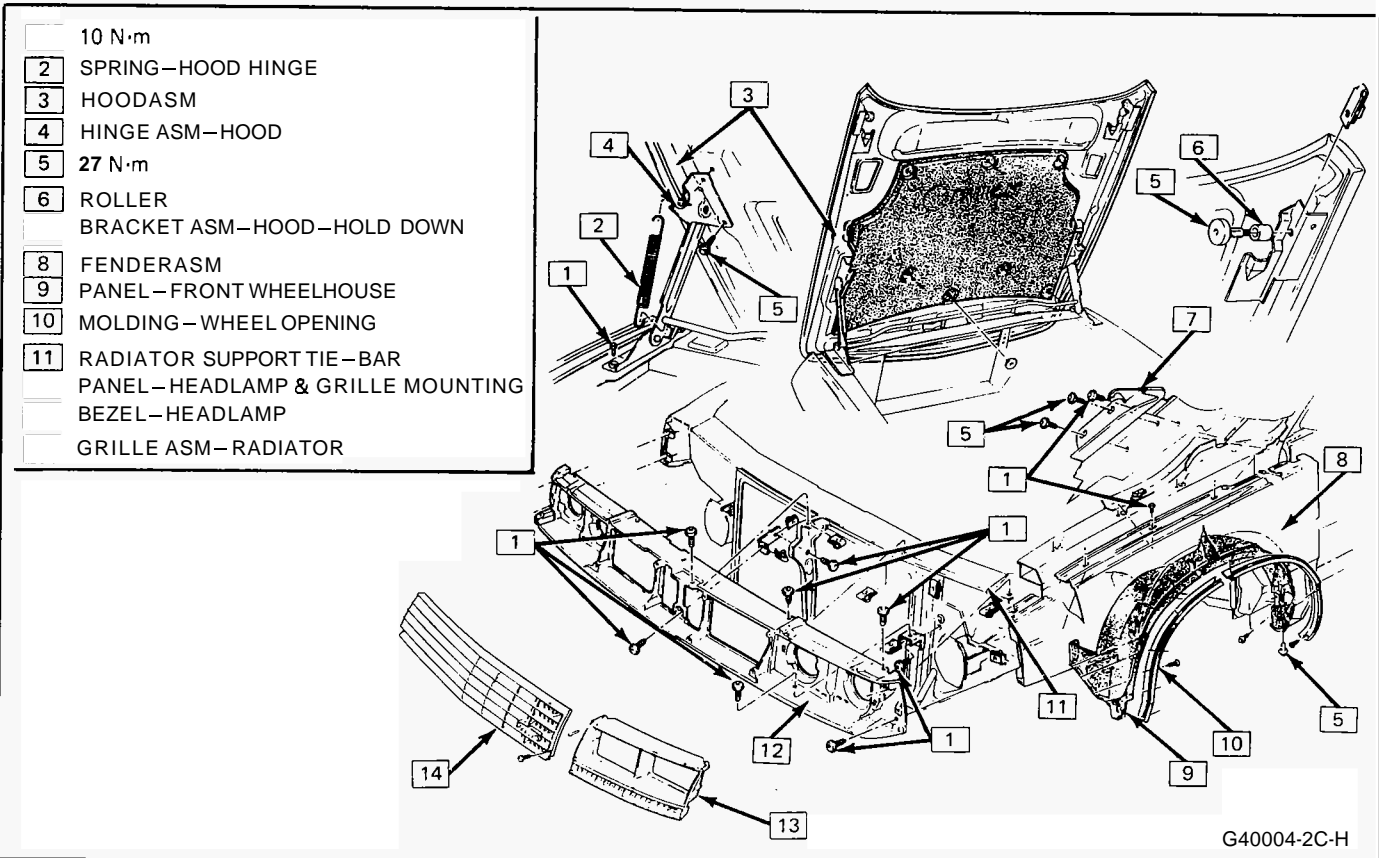

Figure 2C-13 Front End Sheet Metal ("H" Car)