

# SECTION 1A

# HEATING AND VENTILATION

## CONTENTS

### General Description

Ventilation System .....	1A-1
Standard Ventilation System .....	1A-1
Operating Tips .....	1A-1
Heater Control Assembly .....	1A-1
<b>Diagnosis</b>	
Heater Electrical Wiring .....	1A-2
Insufficient Heating .....	1A-6
Inadequate Removal of Fog or Ice .....	1A-7
Too Warm in Car .....	1A-7
Blower Inoperative .....	1A-7
Miscellaneous .....	1A-8

### On-Car Service

Heater Control Assembly .....	1A-8
Temperature Control, Power Vent and Heater/Defroster Cables .....	1A-8
Temperature Control Cable Adjustment .....	1A-8
Vent Control Cables .....	1A-9
Heater Hoses .....	1A-9
Heater Core .....	1A-9
Blower Motor .....	1A-11
Blower Resistor .....	1A-11

## GENERAL DESCRIPTION

### VENTILATION SYSTEM

The base heater system has “flow-through” ventilation. Ram air flows into the car when it is moving. When the car is not in motion, you can get a steady flow of outside air into the car when the heater fan is running.

With the side windows closed, the flow through ventilation system provides outside air flow into the front air inlet grilles, through the car and out the rear air exhaust valves.

### STANDARD VENTILATION SYSTEM

The standard ventilation system lets you bring outside air into the car in a variety of ways.

To let outside air into the car without heating or cooling it, pull the two “VENT” knobs below the instrument panel. The left knob controls the air flow through the left air outlet. The right knob controls air through the right air outlet. The amount of “ram” air flow will depend on car speed and how far the knobs are pulled out.

For heating or defrosting, close the air vents and use the heater control assembly to the right of the steering column. The upper lever selects the air source, the lower lever controls the temperature.

The upper lever has three heater settings:

- o “VENT” - Air will flow through the instrument panel outlets at the speed set by the fan switch. Set the lower (temperature) lever as desired. If heat is added to the incoming air, some air will be diverted to the heater ducts under the instrument panel.
- o “HEATER” - Air flow is through the heater ducts. Set the lower lever for the most comfortable temperature. For the best heat in the rear seat area, move the upper lever to “HEATER,” the lower lever to the far right and the fan switch to “HI.” Close the windows and “VENT” knobs and be sure the space under the front seat is clear.

- o “DEF” - Most of the air flows through the defroster vents on top of the instrument panel, with some air flow through the heater ducts and side window defroster outlets. For the best defrosting, move the lower lever to the far right and the fan switch to “HI.” Refer to the “Operating Tips” for improved heater and defroster efficiency.

To turn the system off, move the upper lever to “VENT” and the fan switch to “OFF.”

### Operating Tips

- o Clear snow and ice from the hood and air inlet in front of the windshield. This helps the heater and defroster work better and reduces the chances of fogging the inside of the windshield.
- o Run the fan on “HI” for a few moments before driving off. This helps clear the intake ducts of snow and moisture and reduces the chance of fogging the inside of the windows.
- o Always keep the front inlet grilles clear of obstructions (leaves, ice, snow, etc.).
- o Always keep the underseat air path clear of objects.

### HEATER CONTROL ASSEMBLY

The three modes of the base heater system (vent, heat, defrost) are controlled by the functional assemblies within the heater module. These assemblies are defined below:

1. Motor and Fan Assembly (Blower)  
Provides and regulates air flow from the air inlet for further processing and/or distribution.
2. Heater Core  
Transfers heat from engine coolant to inlet air, thus heating the inlet air.
3. Temperature Valve  
Regulates the amount of air passing through the heater core, thus controlling the temperature and mix of heated and ambient air.
4. Mode (Defroster) Valve

Regulates the flow and distribution of processed air to the distribution (heater or defroster) ducts.

### 5. Vent Valve

Regulates the flow of non-processed (outside) air into the passenger compartment.

The operation of these assemblies is controlled by the levers and switch on the control head. Depending on model application, two (2) and three (3) indexed snap-in cables are attached to the module and control levers.

The temperature cable has the slider-type, self-adjust feature. As the temperature lever of the control head is cycled through its full range of travel, the cable clip will assume a position assuring that the temperature valve will seat in both extreme positions. The vent and/or defrost cables also have the self-adjusting feature. Blower speeds (OFF-LO-MED-HI) are controllable in all modes (VENT, HEAT, DEFROST) by the switch on the control head.

Blending air between modes can be done by varying the mode selector. Varying the selector between "Heat" and "Defrost" will allow more air or less air to be directed out either the defroster outlet or the heater outlet. The closer the mode selector is positioned to the "Heater" position, the larger the amount of air coming out the heater outlet. The closer the mode selector is positioned to "Defrost," the larger the amount of air going to the windshield. The temperature of this air is governed by the temperature lever position.

Side window defogging is provided via ducts in the outboard corners of the instrument panel. Maximum air flow from these vents will be in the "Heater" mode with reduced air flow in the "Defrost" mode.

Varying the mode selector between "Heater" and "Vent" positions likewise varies the proportion of air coming out the heater outlet and the center vent outlets. With the selector in some midway position, air coming out the center vent outlets will be ambient temperature, while air out the heater outlet will be mixed warm air, its temperature depending on temperature lever position.

In the heat and defrost mode, outside air is driven by the blower to the temperature valve which, dependent upon its position as controlled by the operator, distributes all or some portion of the inlet air through the heater core. The vent valve will prevent air entry into the vent duct and direct this ambient air to the mix portion of the heater module. The air is thus heated, mixed and then directed into either the defroster duct or the heater outlet depending on the position of the mode valve and control lever. A small amount of air is bled to the side window defogger system.

## DIAGNOSIS

### HEATER ELECTRICAL WIRING

The heater wiring diagrams are shown in Electrical Diagnosis, Section 8A, and should be referred to for diagnosis of electrical problems in the heater system.

- |                                     |                                  |
|-------------------------------------|----------------------------------|
| <b>1</b> SIDE WINDOW DEFOG OUTLETS* | <b>4</b> POWER VENT OUTLETS      |
| <b>2</b> DEFROSTER OUTLETS          | <b>5</b> POWER VENT/HEAT OUTLETS |
| <b>3</b> RAM AIR VENT OUTLETS*      | <b>6</b> RAM AIR VENT CONTROLS*  |

\*NOT ON ALL MODELS

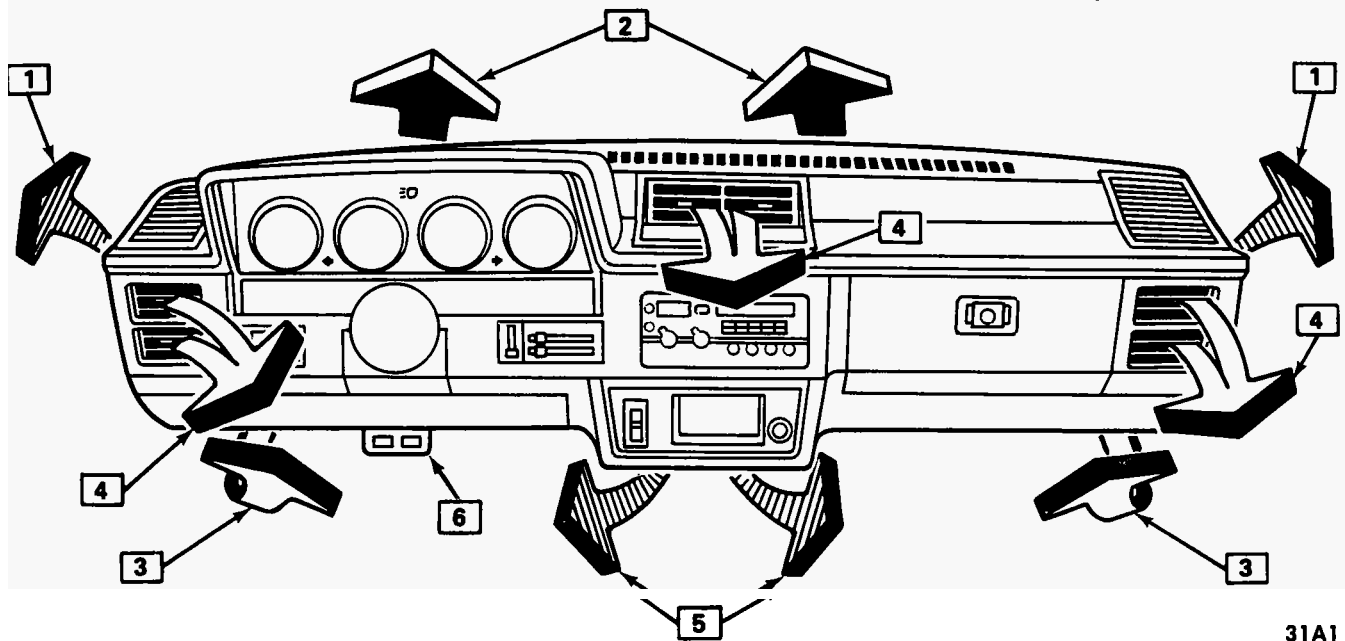

31A1

Figure 1A-1 Heated Ventilation System

- |   |   |
|---|---|
| <b>1</b> THIS POSITION ALLOWS OUTSIDE AIR FLOW TO FLOOR OUTLET. (ADDITIONAL VENTED AIR CAN BE DISTRIBUTED INSIDE CAR BY OPERATING VENT KNOBS.)  | <b>3</b> THIS POSITION ALLOWS ABOUT 80% AIR FLOW TO WINDSHIELD AND 20% TO FLOOR.  |
| <b>2</b> POSITION OF THIS SYSTEM SELECTOR LEVER DETERMINES AIR FLOW FROM FLOOR, INSTRUMENT PANEL OR WINDSHIELD OUTLET—IN "HEATER" FLOW IS ABOUT 80% TO FLOOR AND 20% TO WINDSHIELD OUTLETS (AND SIDE WINDOW DEFOGGERS). | <b>4</b> TEMPERATURE LEVER POSITION WILL REGULATE OUTLET AIR TEMPERATURE BY BLENDING THE INCOMING OUTSIDE AIR THROUGH AROUND THE HEATER CORE. |
|   | <b>5</b> THE FAN CONTROL LEVER (OFF - HI) PROVIDES SPEED CONTROL OF THE FAN.  |

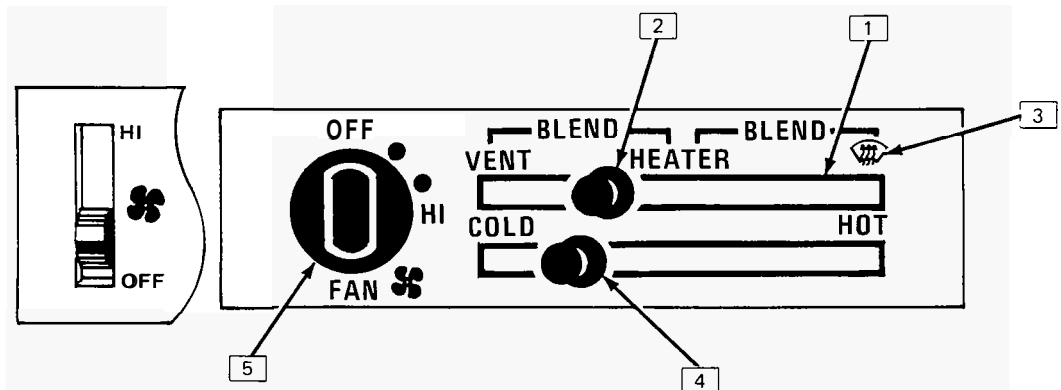

G40029-1A

Figure 1A-2 Heater Control

# 1A-4 HEATING AND VENTILATION

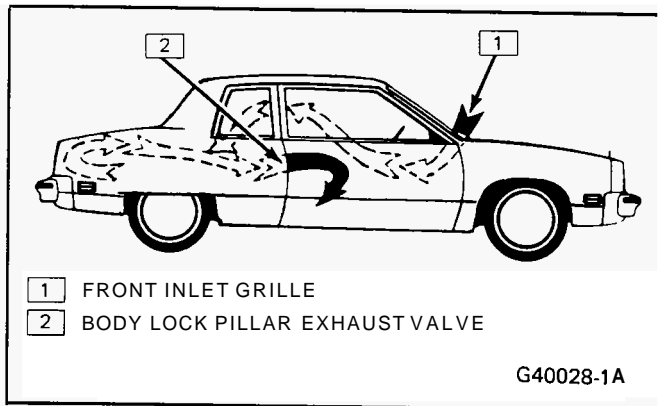

Figure 1A-3 Interior Body Air Flow & Exit

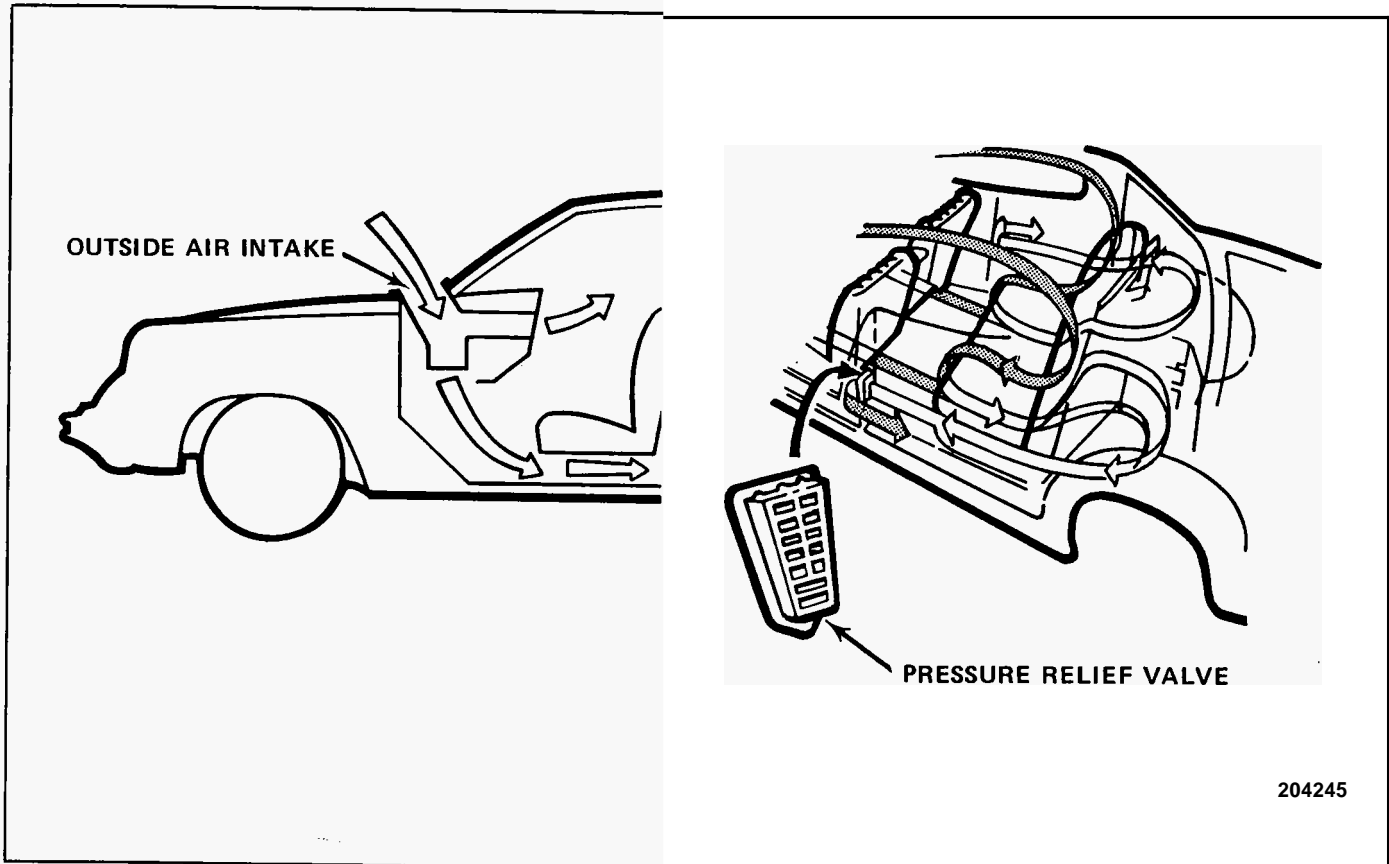

Figure 1A-4 Interior Body Air Flow & Exit-Sedan Models.

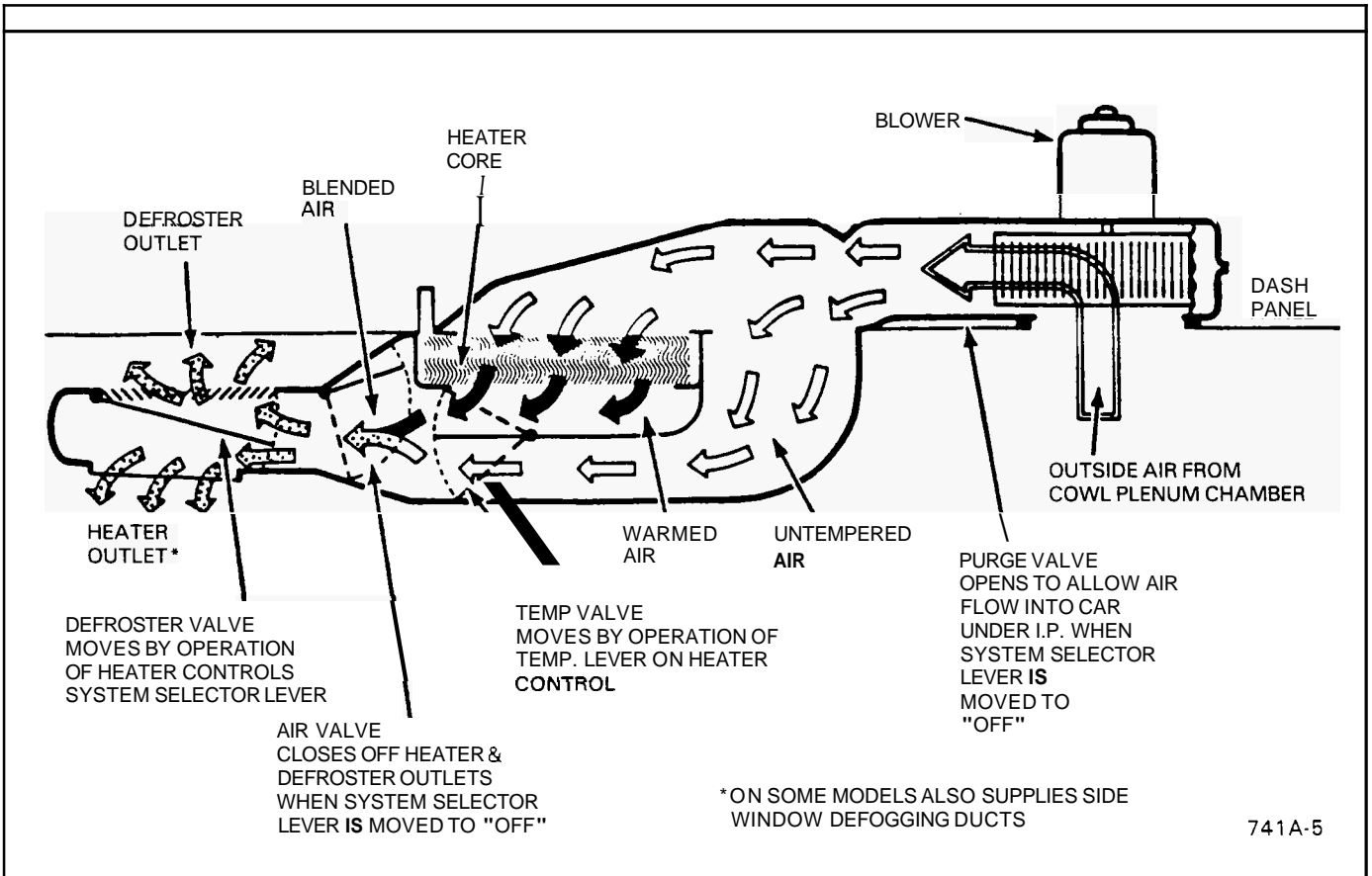

Figure 1A-5 Heater System Air Flow

CONTROLS					SYSTEM RESPONSE			
STEP	MODE LEVER	TEMPERATURE LEVER	FAN SWITCH	BLOWER SPEED	POWER VENT OUTLET	HEATER OUTLET	DEFROSTER OUTLETS	SIDE WINDOW DEFOG OUTLETS**
1	VENT	COLD	OFF	OFF	NO AIR FLOW	NO AIR FLOW	NO AIR FLOW	NO AIR FLOW
2	VENT	COLD	OFF TO HI+	OFF TO HIGH	AMBIENT AIR FLOW	NO AIR FLOW	NO AIR FLOW	NO AIR FLOW
3	HEAT	COLD TO HOT*	HI	HIGH	NO AIR FLOW	COLD TO HOT AIR FLOW	MINIMUM COLD TO HOT AIR FLOW	MINIMUM AIR FLOW
4	DEFROST	COLD TO HOT*	HI	HIGH	NO AIR FLOW	MINIMUM COLD TO HOT AIR FLOW	COLD TO HOT AIR FLOW	AIR FLOW

'CYCLE CONTROL TO TEST

\*\*NOT ALL MODELS

G40030-1A

Figure 1A-6 Heater Functional Test

## HEATER TROUBLE DIAGNOSIS

## INSUFFICIENT HEATING

Possible Cause	Possible Correction
Slow warming in car.	Incorrect operation of controls. Advise operator of proper operation of heater controls. Explain operation of vents and controls. Low coolant level. Check control cable and blower operation.
Objectionable engine or exhaust fumes in car.	Check for seal between engine compartment and plenum. Check for proper sealing between air inlet duct assembly and cowl. Locate and seal any other air leaks.
Cold drafts on floor.	Check operation and adjustment of vent cables. Advise operator of proper operation of heater system. Advise operator to use blower to force air to rear seat area. Check to be sure front floor mat is under floor mat retainer at cowl.
Insufficient heat to rear seat.	Obstruction on floor, possibly wrinkled or torn insulator material between front seat and floor. Advise operator to use <b>HI</b> blower speed.
Low engine coolant level - drop in heater air temperature at all blower speeds.	Check radiator and cooling system for leaks, correct and fill to proper level. Run engine to clear any air lock.
Failure of engine cooling system to warm up.	Check engine thermostat; replace if required. Check coolant level.
Kinked heater hoses.	Remove kink or replace hose.
Foreign material obstructing water flow through heater core.	Remove foreign material if possible, otherwise, replace core - can usually be heard as squishing noise in core.
Temperature valve improperly adjusted. Air doors do not operate.	Adjust cable. Check installation and/or adjustment of air control or air-defrost cable.

## INADEQUATE REMOVAL OF FOG OR ICE

Possible Cause	Possible Correction
Air valve does not open. Defroster valve does not open fully.	Check cable operation.
Air valve does not open.	Check installation and/or adjustment of air control or air-defrost cable.
Temperature valve does not open.	Check and adjust temperature control cable if necessary.
Obstructions in defroster outlets at windshield.	Remove obstruction. Look for and <b>fix</b> loose instrument panel pad cover at defroster outlet.
Damaged defroster outlets.	Reshape outlet flange with pliers. The outlet should have a uniform opening.
Blower motor not connected.	Connect wire. Check ground.
Inoperative blower motor.	Check heater fuse and wiring. Replace motor if necessary.
Inoperative blower motor switch.	Replace switch if necessary.

## TOO WARM IN CAR

Possible Cause	Possible Correction
Temperature valve improperly adjusted.	Adjust temperature cable.
Incorrect operation of controls.	Advise operator of proper operation of heater system.

## BLOWER INOPERATIVE

Cause	Correction
Blown fuse.	Replace fuse.
Open circuit.	Repair circuit between ignition switch, blower switch and blower motor.
Inoperative blower motor switch.	Replace faulty switch.
Shorted or open blower resistor.	Check blower motor resistor

## 1A-8 HEATING AND VENTILATION

---

Inoperative motor.            Replace motor.

◦

---

## MISCELLANEOUS

---

Possible Cause	Possible Correction
Blown fuses caused by short in electrical system.	Locate and correct short.
Front floor mat wet under heater caused by improperly sealed windshield or leaking heater core.	Reseal windshield, or lead-in from radio antenna. Repair (if possible) or replace heater core. Check for proper seal to cowl and for leak at hose connection on heater core. Hose leaking into the heater case is often misdiagnosed as leaking core.
Heater "gurgle," whine or "swish."	Check engine coolant level in radiator. Check for obstruction in core and/or hoses.

---

## ON CAR SERVICE

Refer to Section 8C for all heater and defroster duct work service procedures.

### CONTROL CABLES

For installation and removal, see Figures 1A-12 through 1A-16.

### VENT CONTROL CABLES

For installation and removal, see Figures 1A-17 through 1A-20.

### HEATER HOSES AND WATER VALVES

For routing, installation and removal, see Figures 1A-21 through 1A-26.

### HEATER CONTROL ASSEMBLY

#### Remove or Disconnect

1. Negative battery cable
2. IP trim plate (see Section 8C1, 8C2, 8C3 or 8C4)
3. Four (4) control panel screws and pull control assembly away from the instrument panel
4. Electrical connections
5. Control cables (see Figures 12 through 16)

#### Install or Connect

1. Control cables
2. Electrical connections
3. Four control panel screws
4. IP trim plate

5. Negative battery cable

## TEMPERATURE CONTROL, POWER VENT AND HEATER/DEFROSTER CABLES

*Figures 17 through 20*

#### Remove or Disconnect

1. Heater control from the instrument panel
2. Cables at module and control
3. Cables

#### Install or Connect

1. Cables at module
2. Cables at heater control
3. Heater to instrument panel

## TEMPERATURE CONTROL CABLE ADJUSTMENT

The temperature control cable is self-adjusting. Following cable installation move the temperature lever briskly from full hot position. At approximately two-thirds control travel additional effort will be required to complete the adjustment. Adjust cable length further if necessary, by holding lever in full hot position and pushing the sliding clip forward 1.5 mm (1/16"). The cable clip is now set and should provide uniform effort from full cold to full hot and back with audible temperature valve stop contact upon reaching these positions. Repeat procedure if required.



**VENT CONTROL CABLES***Figures 17 through 20***↔ Remove or Disconnect**

1. Screw securing vent control assembly to instrument panel.
2. Cable from vent valve actuator.
3. Cable

**→← Install or Connect**

1. Cable to vent valve actuator
2. Screw securing vent control assembly to instrument panel.

**HEATER HOSES**

For routing, installation and removal, see Figures 21 through 26.

Check all heater hose routing for installation to avoid contact with any obstruction that could result in a damaged hose. Some hoses are equipped with conduit in areas where rubbing may occur. Be sure to always replace conduit when replacing a hose.

**HEATER CORE****A Series****↔ Remove or Disconnect**

1. Drain cooling system.
2. Coolant hoses at the heater core.
3. Heater duct and the heater case side cover (covers the heater core hose tubes)
4. Heater lower outlet
5. Two (2) housing cover to air valve housing clips
6. Housing cover
7. Core retaining straps
8. Core tubing retainers and remove the core.

**→← Install or Connect**

1. Core and the core tubing retainers
2. Core retaining straps
3. Housing cover
4. Two (2) housing cover to air valve housing clips
5. Heater lower outlet
6. Heater duct and the heater case side cover (covers the heater core hose tubes)
7. Coolant hoses at the heater core
8. Refill the cooling system, start engine, check for leaks.

**B Series****↔ Remove or Disconnect**

1. Negative battery cable, resistor and blower motor wires
2. Heater core ground strap from dash panel
3. Drain cooling system and disconnect both heater hoses.

4. Seven heater and blower case to plenum case screws and remove case. (At this time, it may be necessary to remove temperature air valve.)
5. Four heater core shroud screws and remove shroud and core assembly.
6. Three screws and core mounting clamps to separate core and shroud.

**→← Install or Connect**

1. Three screws and core mounting clamps to assemble core and shroud.
2. Four heater core shroud screws and attach shroud and core assembly.
3. Seven heater and blower case to plenum case screws and remove case. (At this time it may be necessary to install temperature air valve, if removed.)
4. Both heater hoses
5. Heater core ground strap to dash panel
6. Negative battery cable, resistor, and blower motor wires.
7. Refill cooling system, start engine, check for leaks.

**C Series****□ Remove or Disconnect**

1. Negative battery cable
2. Drain cooling system
3. Right sound insulator
4. Center I.P. trim plate
5. Lower I.P. trim plate
6. Right speaker grille and speaker to reach programmer attaching bolt
7. Wire and hoses from programmer
8. Programmer linkage cover and linkage
9. Programmer
10. Heater core cover
11. Splash cover to access heater hoses
12. Heater hoses
13. Heater core

**■ Install or Connect**

1. Heater core
2. Heater hoses
3. Splash cover
4. Heater core cover
5. Programmer
6. Programmer linkage and linkage cover
7. Wires and hoses to programmer
8. Right speaker and speaker grille
9. Lower I.P. trim plate
10. Center I.P. trim plate
11. Right sound insulator
12. Fill cooling system
13. Negative battery cable

## 1A-10 HEATING AND VENTILATION

### E Series

#### Remove or Disconnect

1. Negative battery cable
2. Drain cooling system
3. Heater hoses from heater core
4. Instrument panel (see Section 8C)
5. Defroster ducts
6. Vacuum hoses and temperature cable
7. Blower resistor
8. A/C heater assembly to dash panel nuts (3)
9. A/C heater assembly to dash screw and clip (inside car)
10. A/C heater assembly
11. Heater core

#### Install or Connect

1. Heater core
2. A/C heater assembly
3. A/C heater assembly to dash screw and clip (inside car)
4. A/C heater assembly to dash panel nuts (3)
5. Blower resistor
6. Vacuum hoses and temperature cable
7. Blower resistor
8. Instrument panel (see Section 8C)
9. Heater hoses from heater core
10. Negative battery cable
11. Fill cooling system, start engine, check for leaks.

### G Series

#### Remove or Disconnect

1. Negative battery cable
2. Drain cooling system
3. Heater hoses from heater core
4. Electrical connections and wires from module cover
5. Front module cover screws
6. Heater core

#### Install or Connect

1. Heater core
2. Front module cover screws
3. Electrical connections and wires to module cover
4. Heater hoses to heater core
5. Negative battery cable
6. Filling cooling system, start engine, check for leaks.

### H Series

#### Remove or Disconnect

1. Negative battery cable
2. Drain cooling system
3. Right sound insulator
4. Center I.P. trim plate
5. Lower I.P. trim plate

6. Right speaker grille and speaker to reach programmer attaching bolt
7. Wires and hoses from programmer
8. Programmer linkage cover and linkage
9. Programmer
10. Heater core cover
11. Splash cover to access heater hoses
12. Heater hoses
13. Heater core

#### Install or Connect

1. Heater core
2. Heater hoses
3. Splash cover
4. Heater core cover
5. Programmer
6. Programmer linkage and linkage cover
7. Wires and hoses to programmer
8. Right speaker and speaker grille
9. Lower I.P. trim plate
10. Center I.P. trim plate
11. Right sound insulator
12. Fill cooling system
13. Negative battery cable

### J Series

#### Remove or Disconnect

1. Drain cooling system
2. Heater hoses from heater core
3. Heater outlet deflector
4. Heater core cover
5. Heater core retaining straps and remove heater core.

#### Install or Connect

1. Heater core retaining straps and install heater core.
2. Heater core cover
3. Heater outlet deflector
4. Heater hoses to heater core
5. Fill cooling system, start engine, check for leaks.

### N Series

#### Remove or Disconnect

1. Drain cooling system
2. Hoist vehicle (see Section **OA** for hoisting information)
3. Heater hoses at core
4. Drain tube
5. Lower vehicle (see Section **OA** for hoisting information)
6. Instrument panel sound insulator
7. Lower heating duct and hoses
8. Heater core covers
9. Heater core

Install or Connect

1. Heater core
2. Heater core covers
3. Lower heating duct and hoses
4. Instrument panel sound insulator
5. Hoist vehicle (see Section OA for hoisting information)
6. Drain tube
7. Heater hose to heater core
8. Lower vehicle (see Section OA for hoisting information)
9. Fill cooling system, start engine, check for leaks.

### BLOWER MOTOR

Figures 1A-7 thru 1A-11

Remove or Disconnect

1. Negative battery cable
2. Electrical connections, blower motor and ground strap
3. Blower motor

Install or Connect

1. Blower motor
2. Electrical connections, blower motor and ground strap
3. Negative battery cable

### BLOWER RESISTOR

Figure 1A-27

1. Negative battery cable
2. Electrical connections at blower resistor

3. Blower resistor screws then remove resistor

Install or Connect

1. Blower resistor and resistor screws
2. Electrical connections at blower resistor
3. Negative battery cable

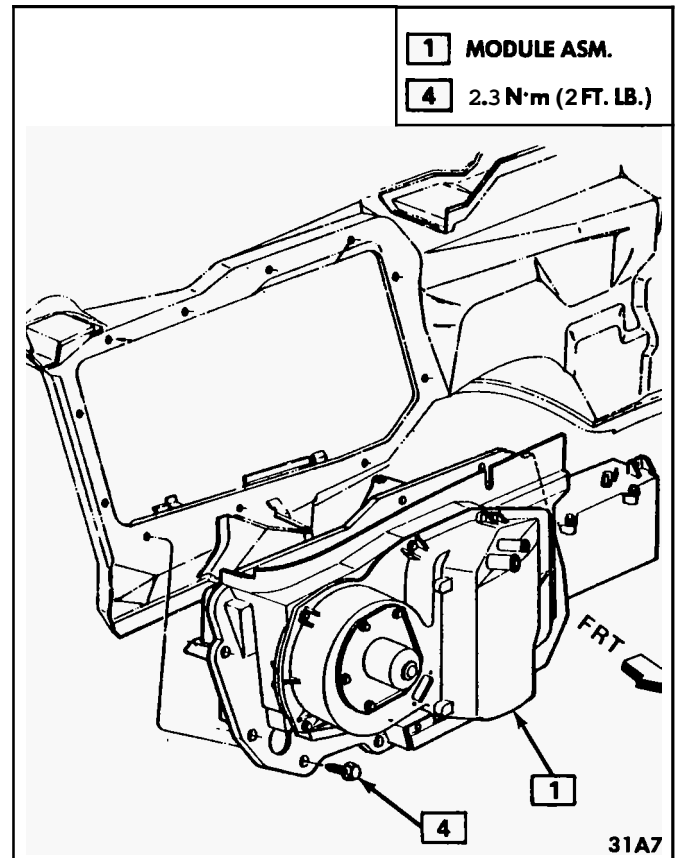

Figure 1A-7 Heater Module-B Series

1A-12 HEATING AND VENTILATION

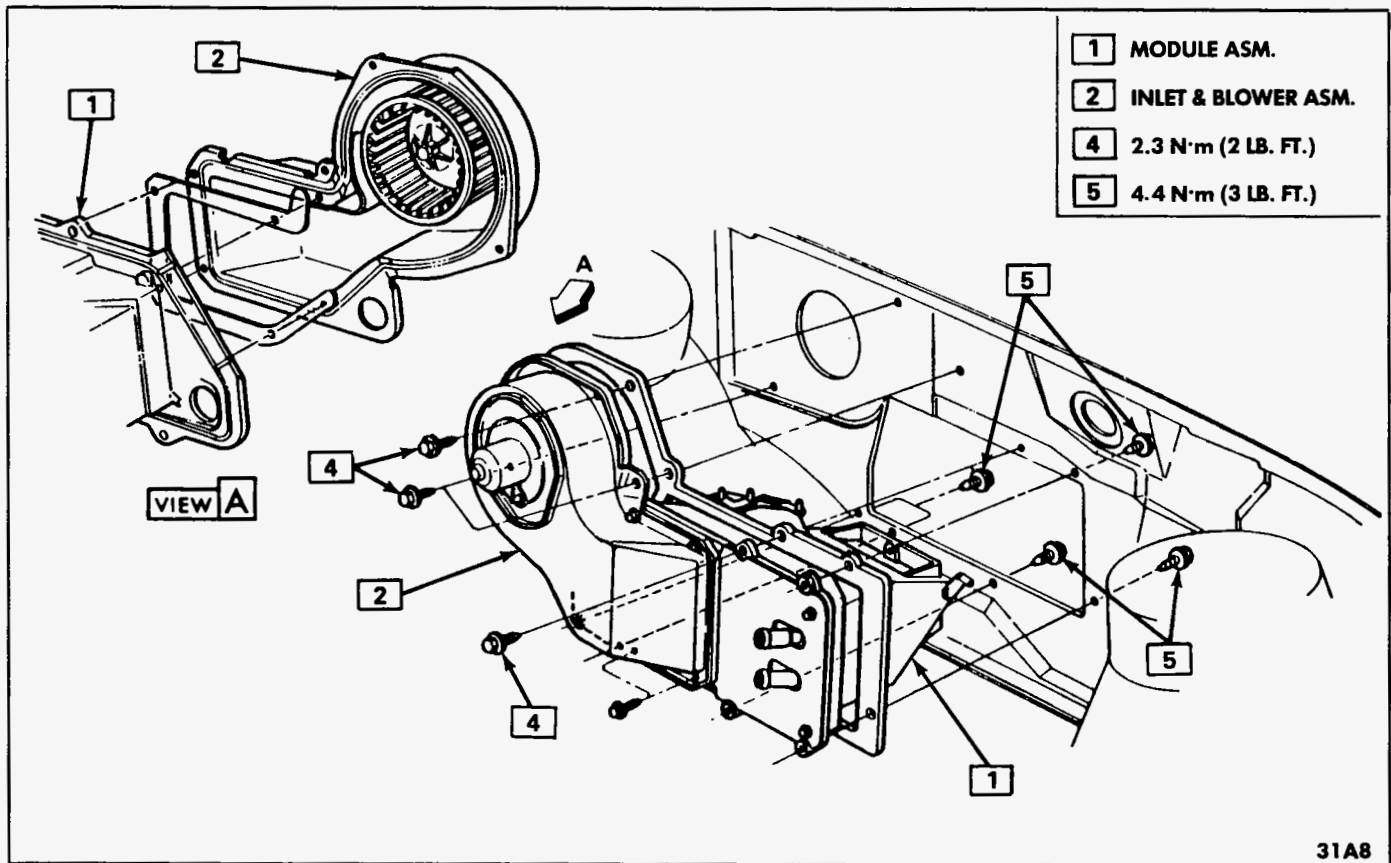

Figure 1A-8 Heater Module-A Series

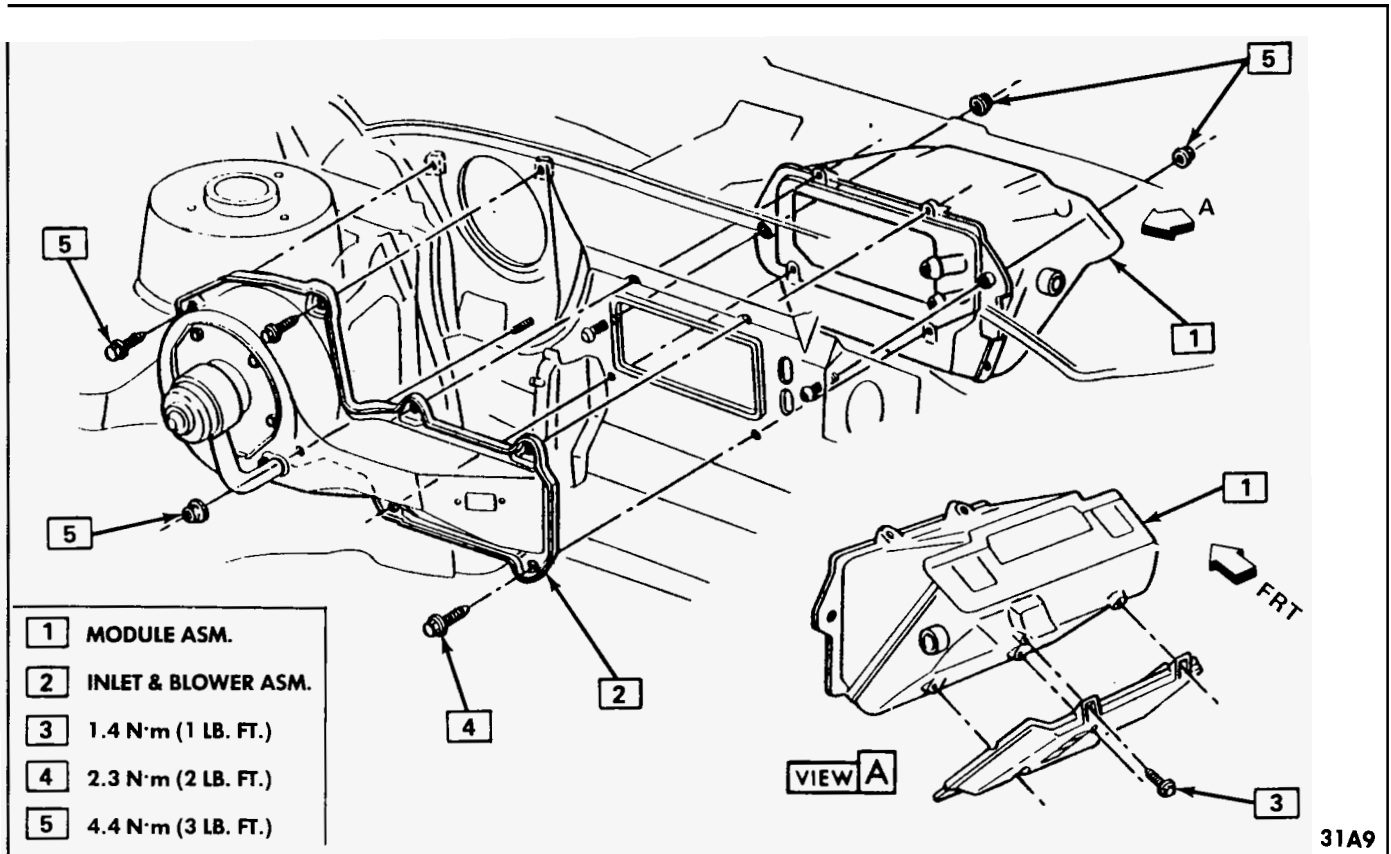

Figure 1A-9 Heater Module-J Series

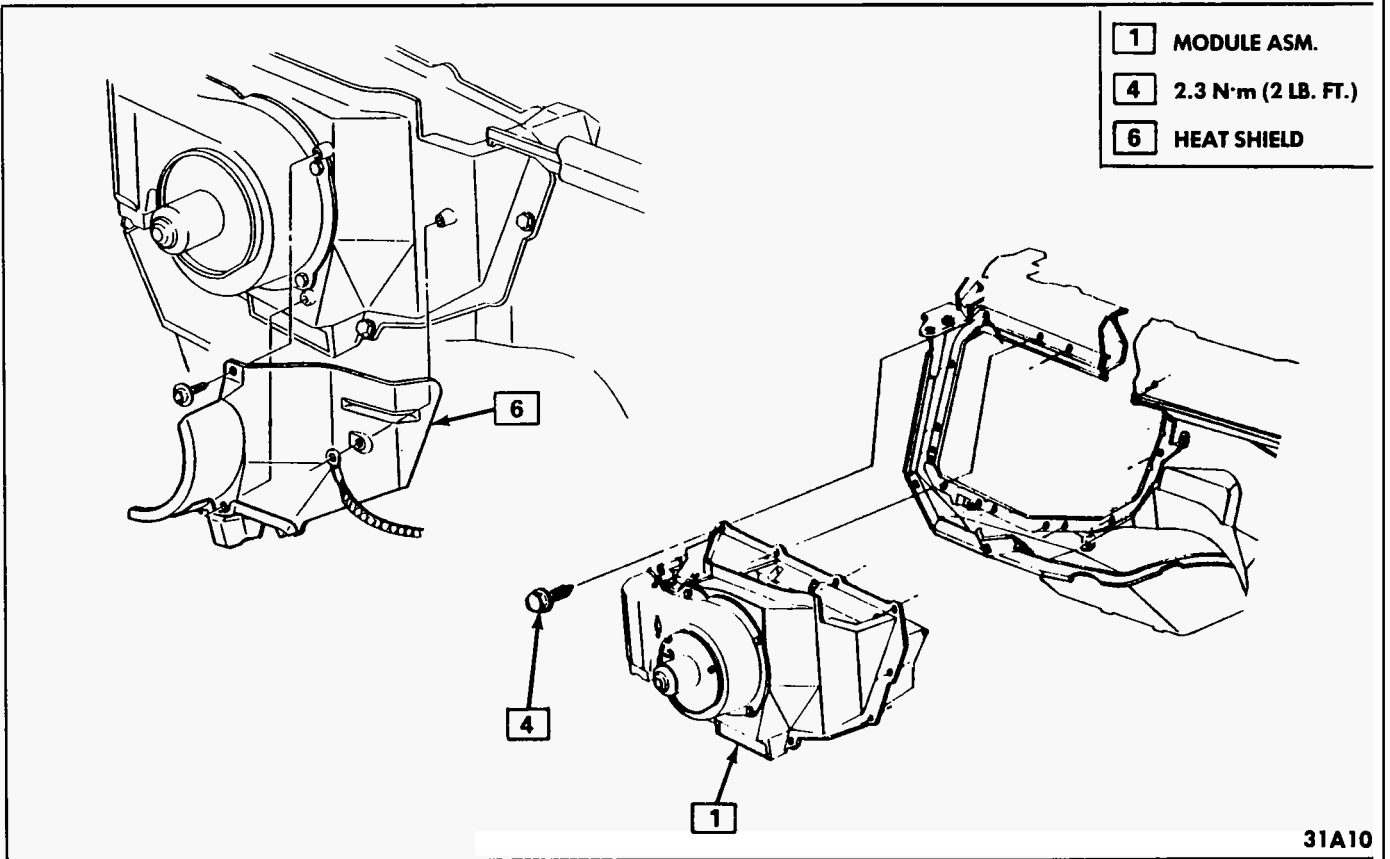

Figure 1A-10 Heater Module-G Series

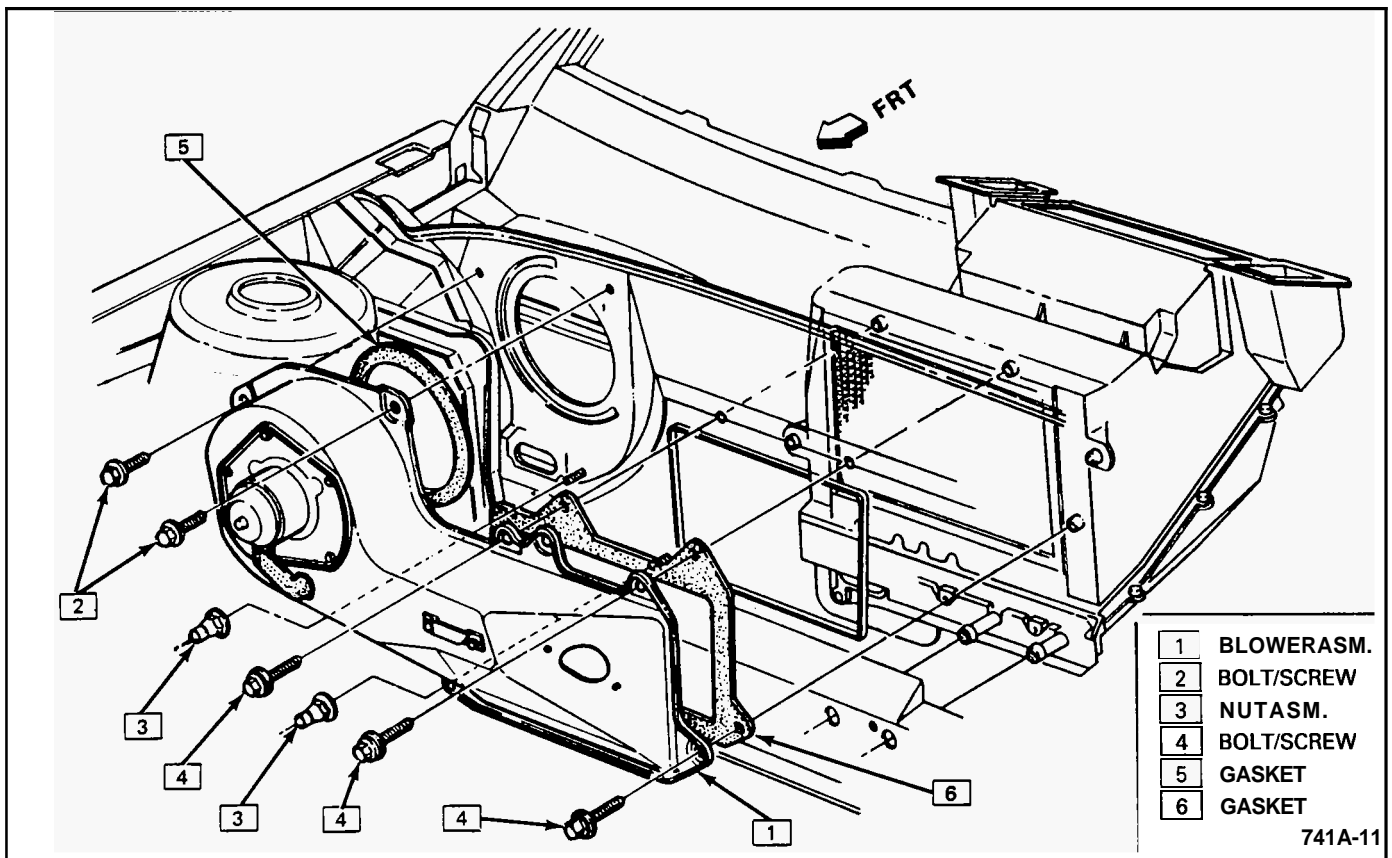

Figure 1A-10A A/C & Heater Blower-N Series

# 1A-14 HEATING AND VENTILATION

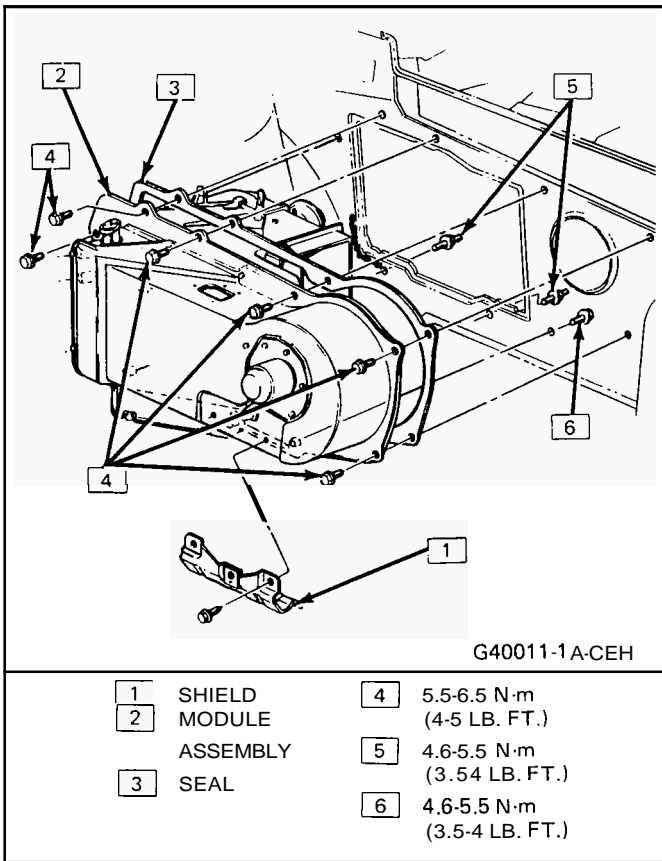

Figure 1A-11 Heater Air Conditioning Module-C-H Series

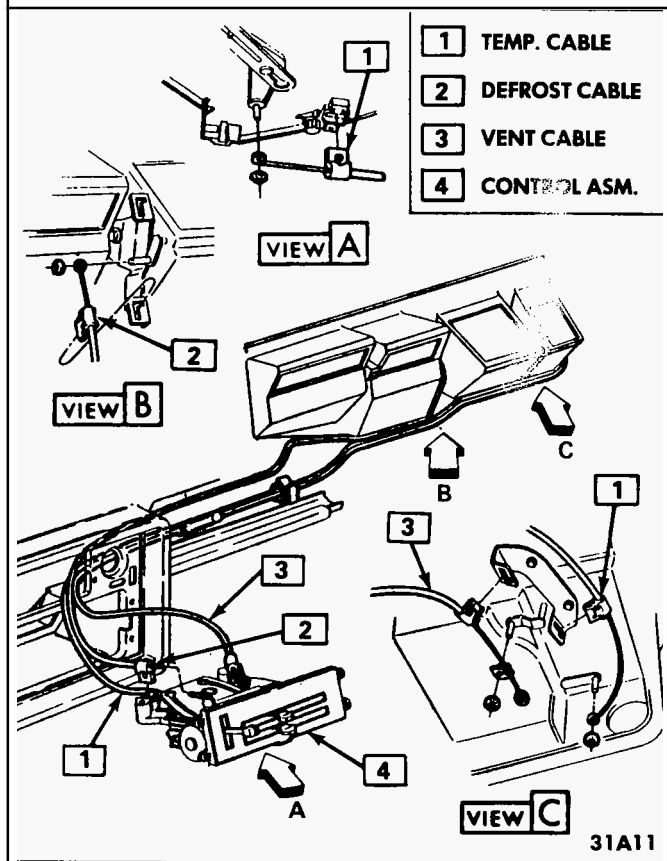

Figure 1A-12 Heater Control Cables-G Series

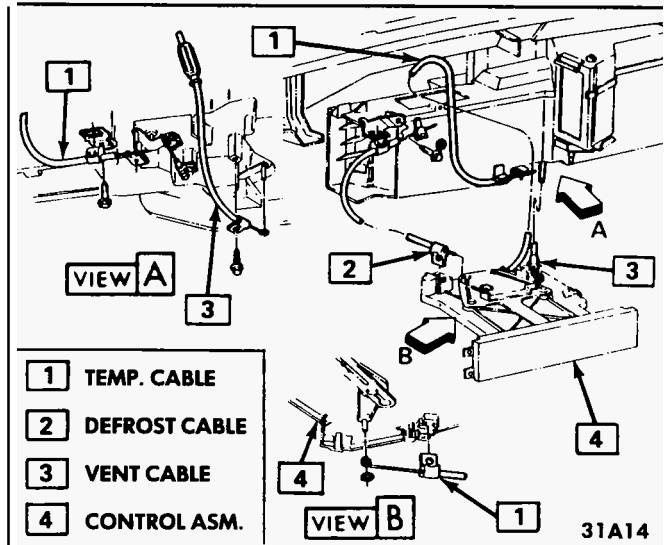

Figure 1A-14 Heater Control Cables-B Series

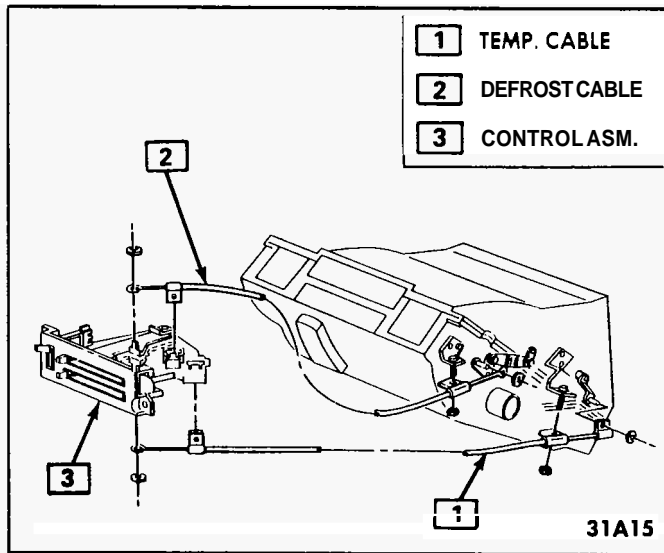

Figure 1A-15 Heater Control Cables-J Series

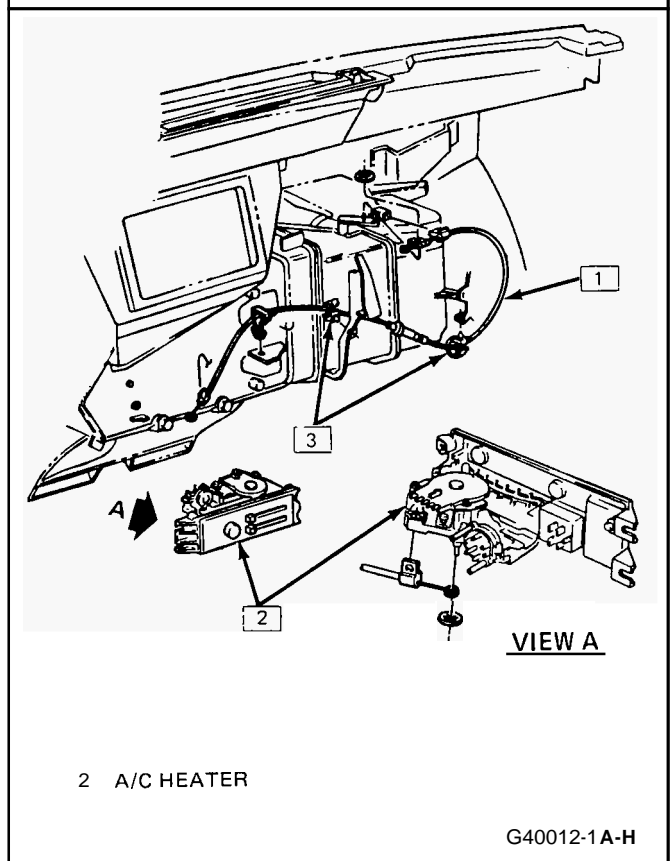

Figure 1A-16 Heater Control Cables-C-H Series

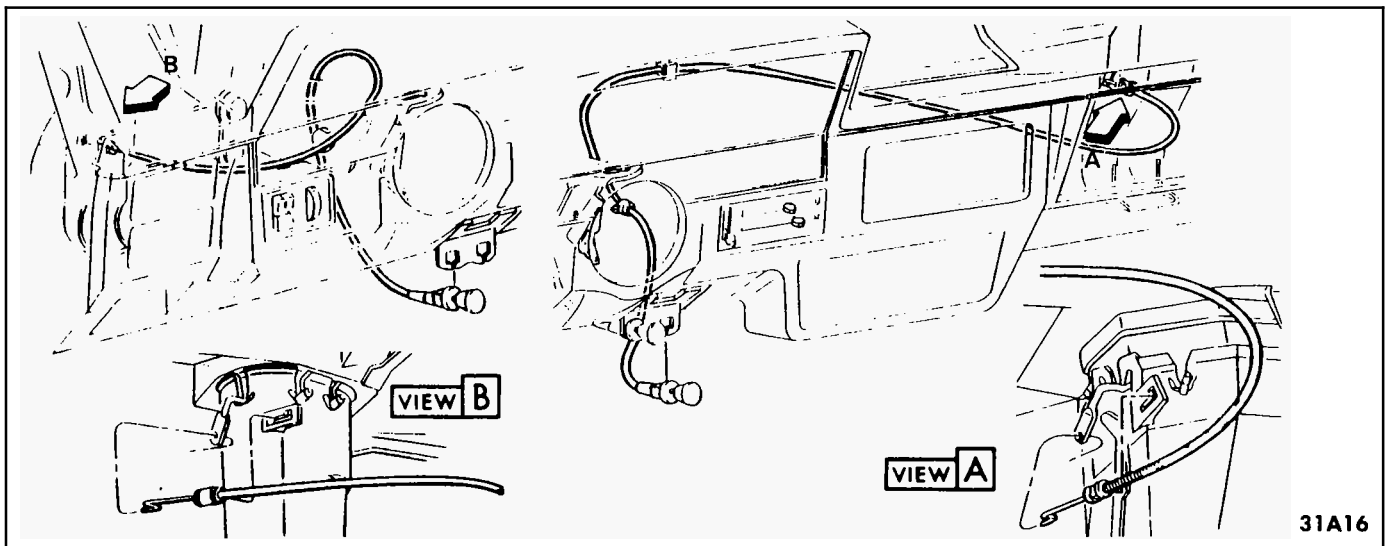

Figure 1A-17 Vent Cables-J Series

1A-16 HEATING AND VENTILATION

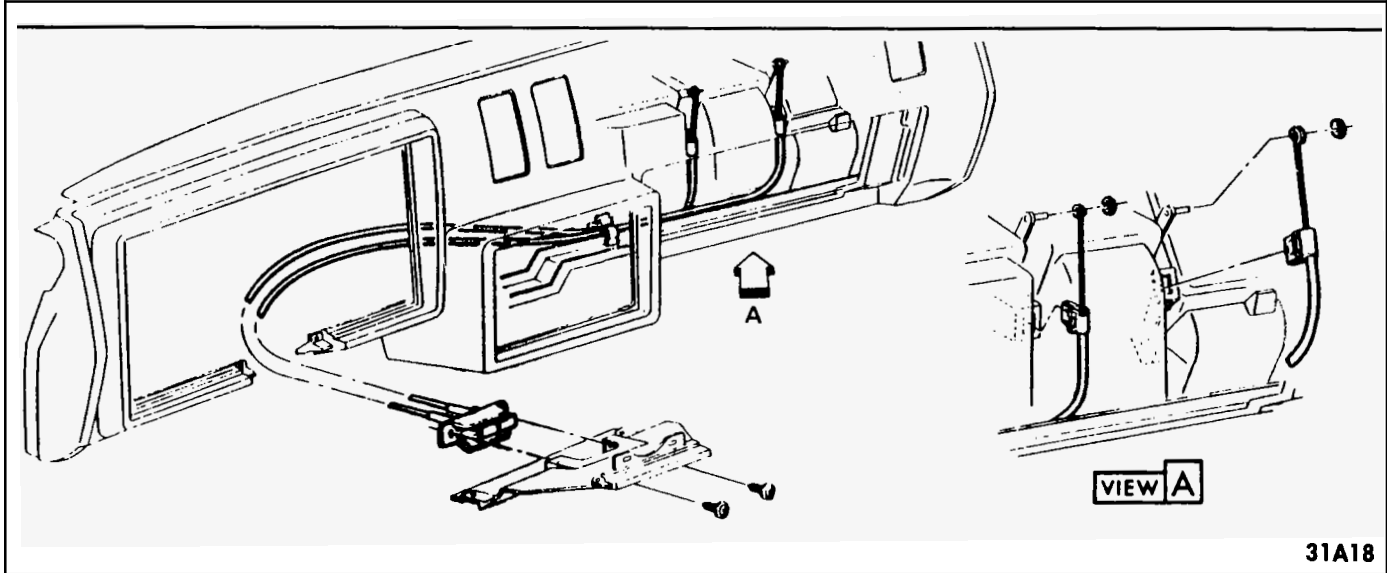

Figure 1A-18 Vent Cables-G Series

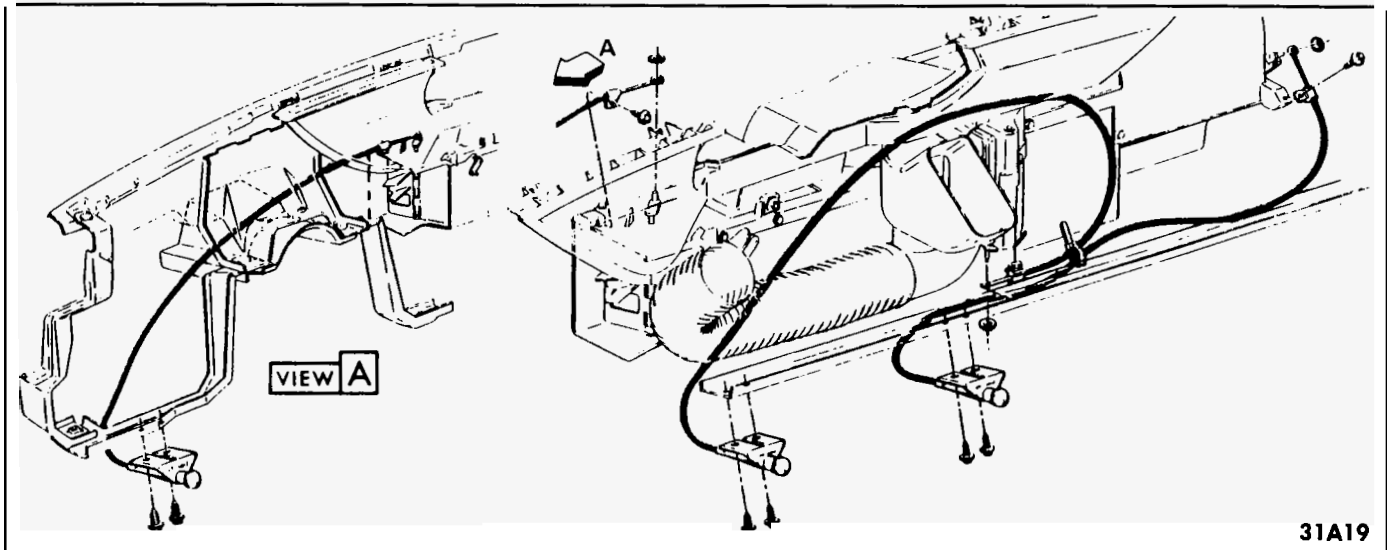

Figure 1A-19 Vent Cables-B Series

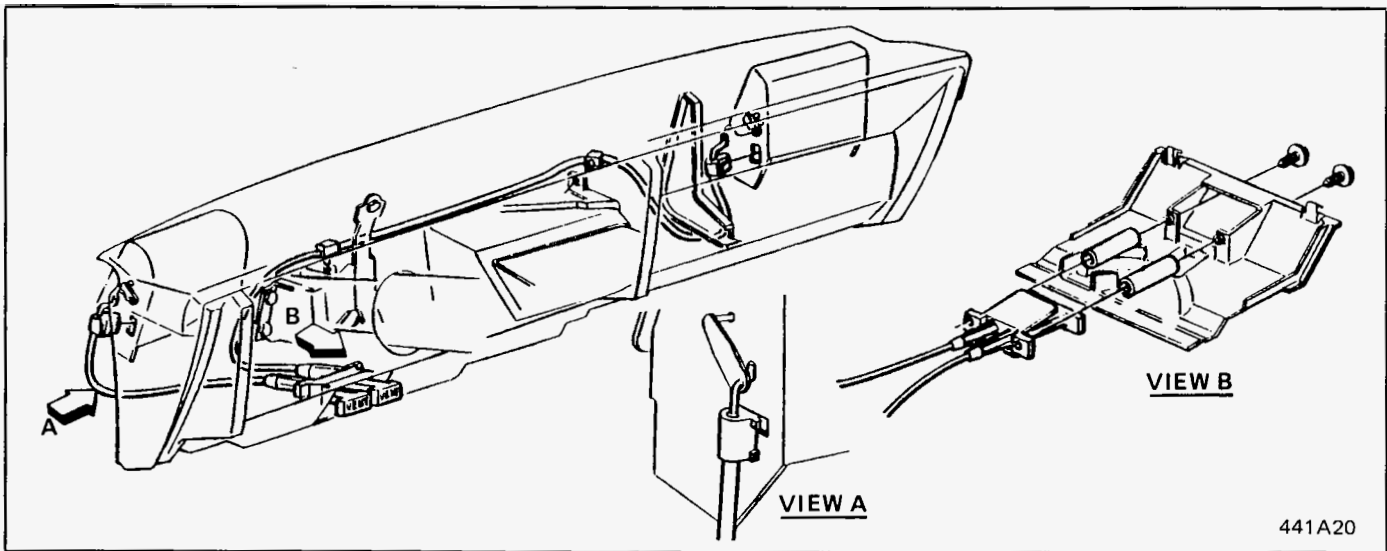

Figure 1A-20 Vent Cables-A Series



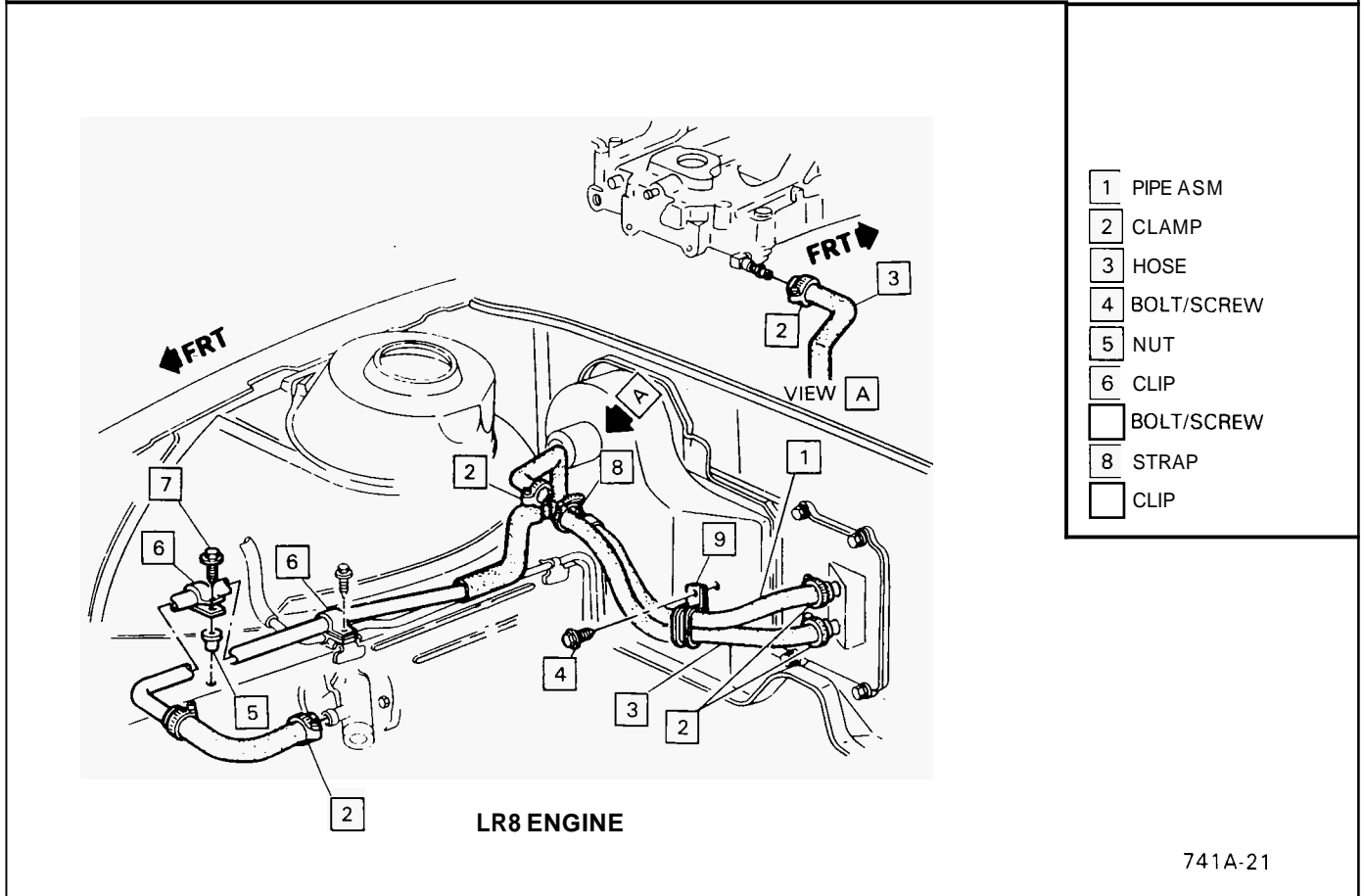
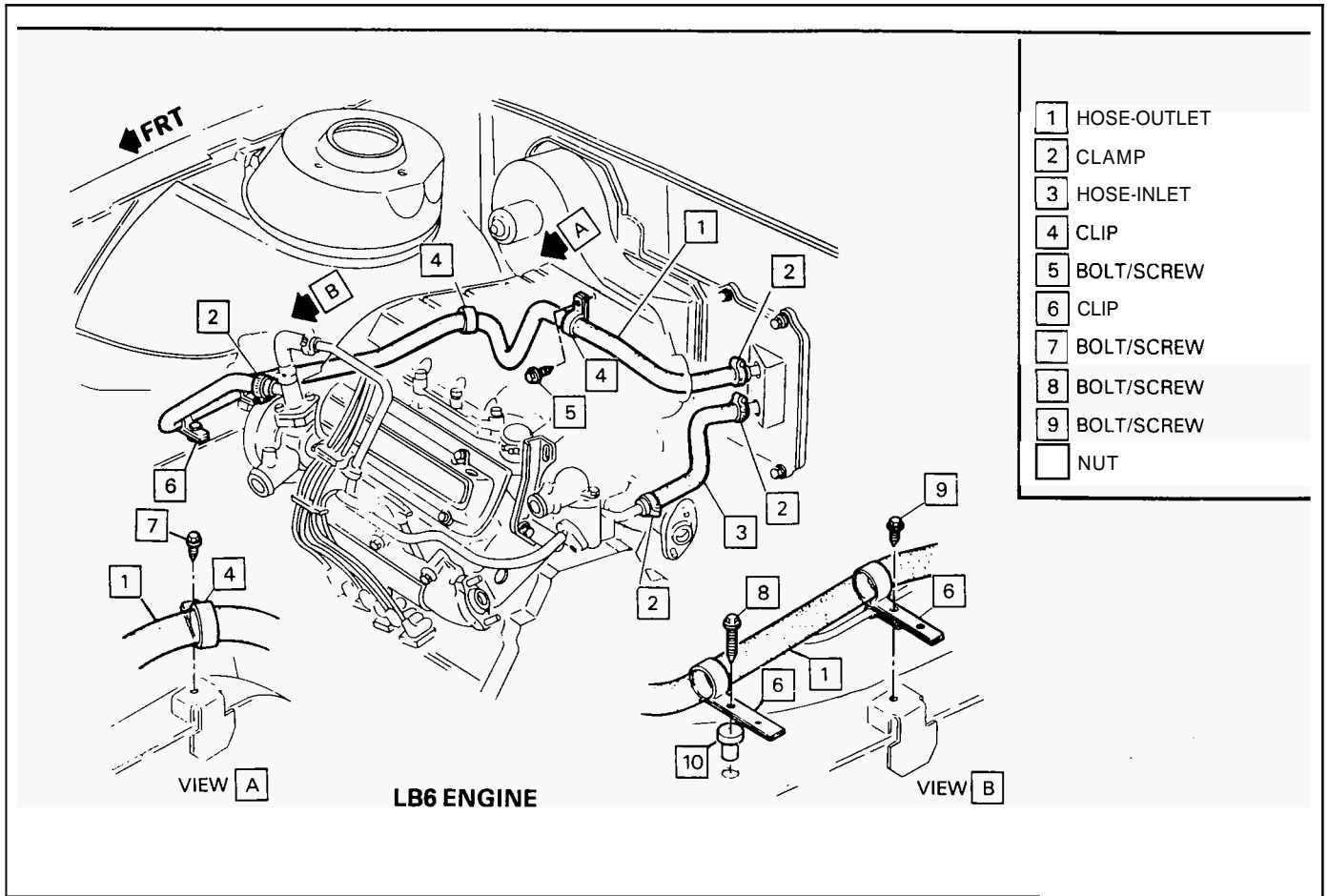

Figure 1A-21 Heater Hoses-A Series

1A-18 HEATING AND VENTILATION

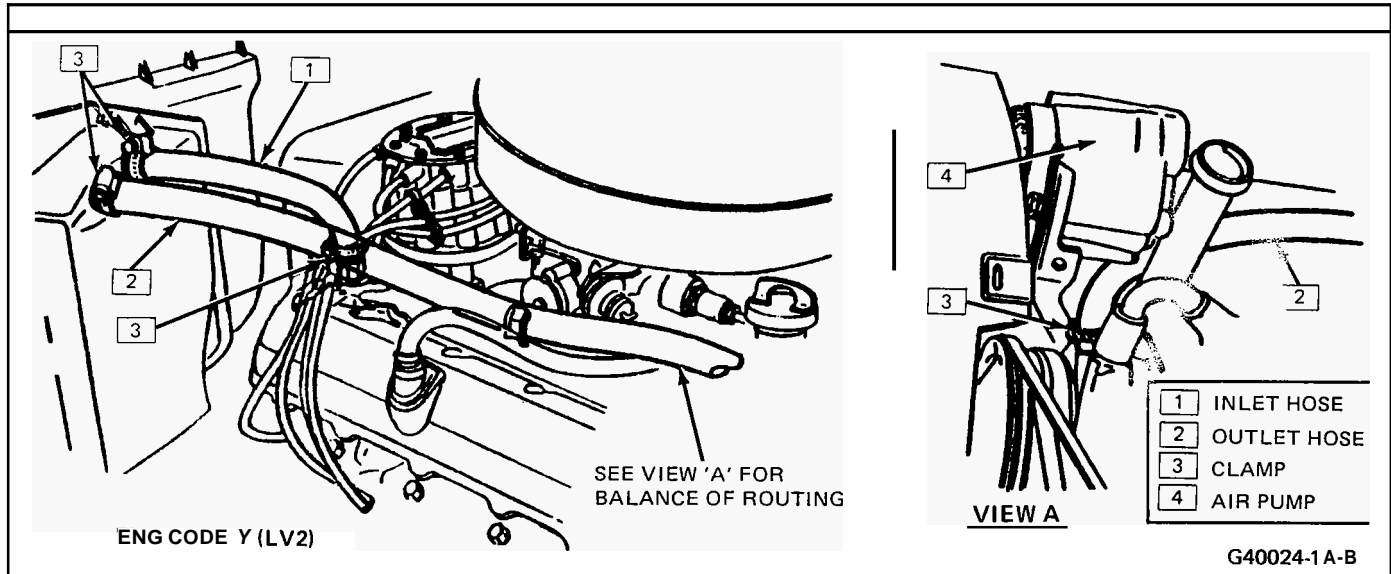

Figure 1A-22 Heater Hoses-B Series

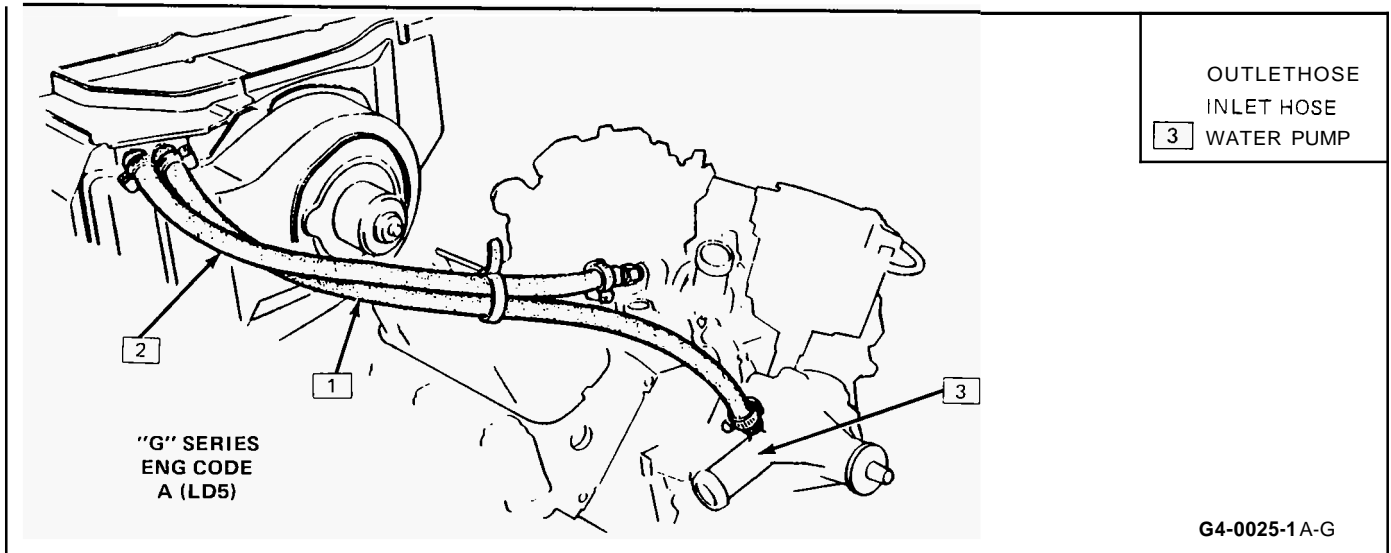

Figure 1A-23 Heater Hoses-G Series

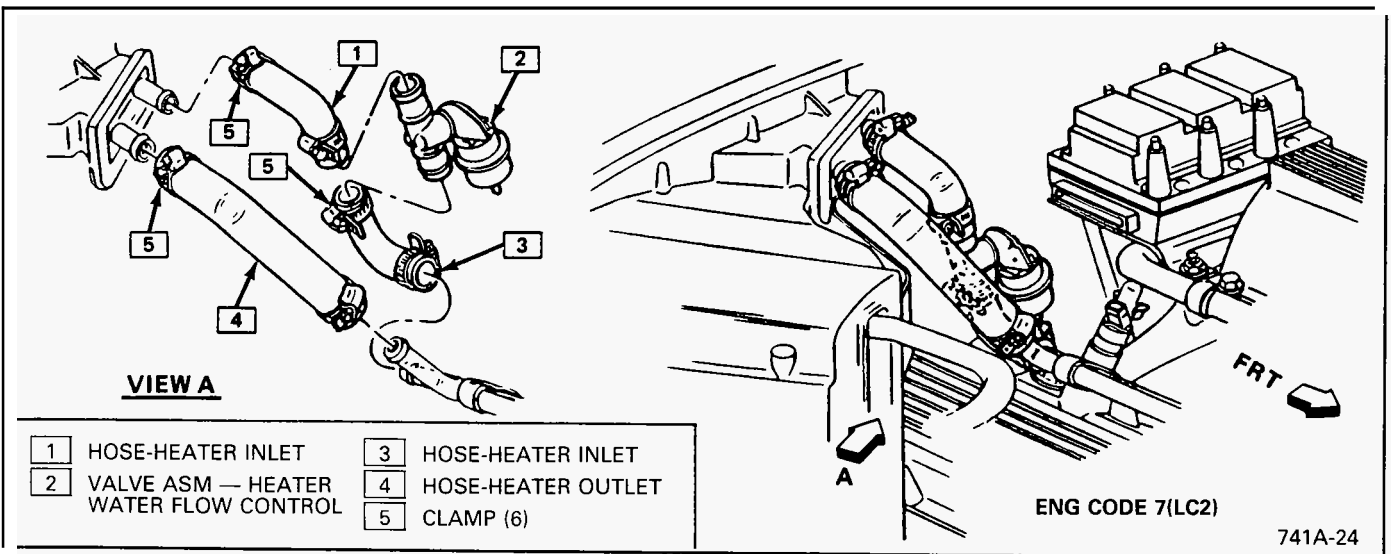
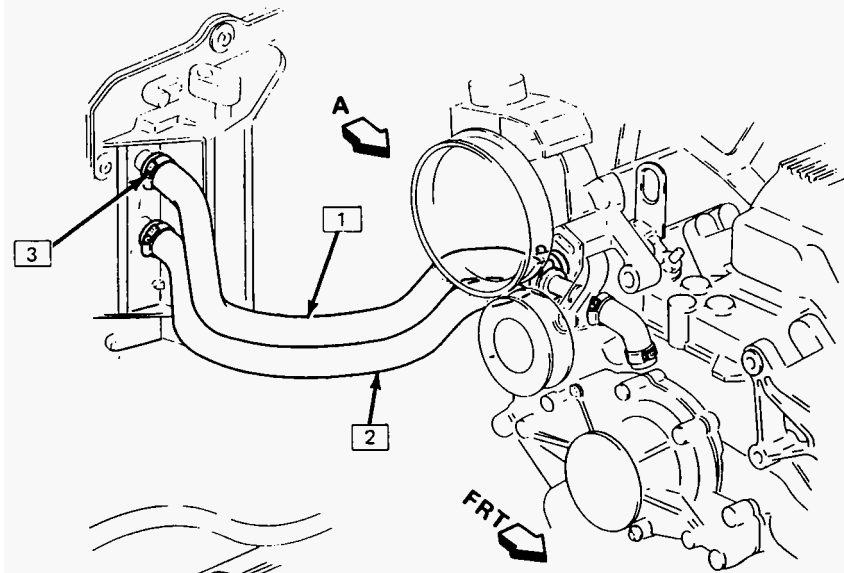
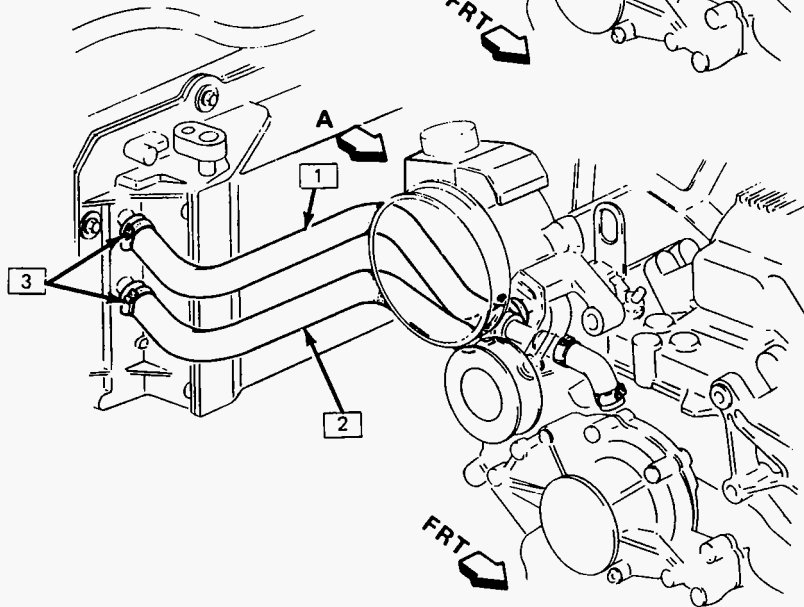
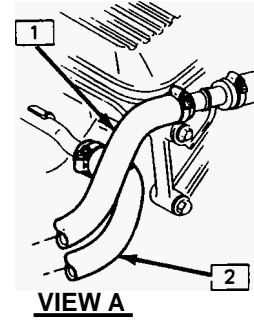

Figure 1A-24 Heater Hoses-G Series



"C-H" SERIES  
ENG CODE (LG3)



" E SERIES  
ENG CODE LG3

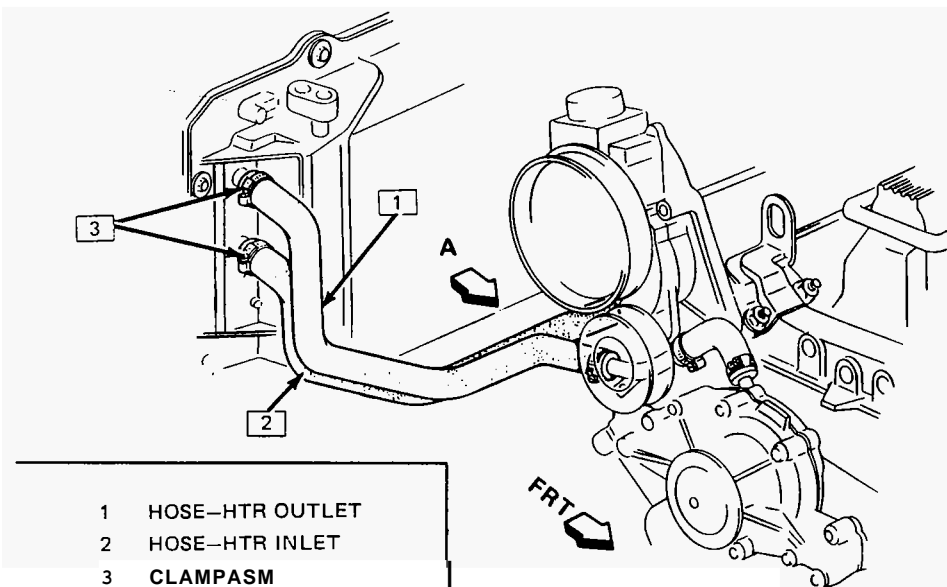
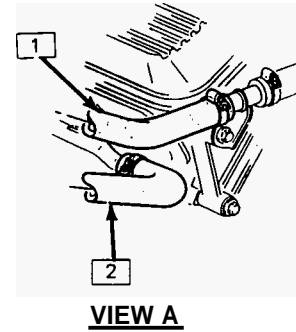

"N" SERIES  
ENG CODE (LN7)

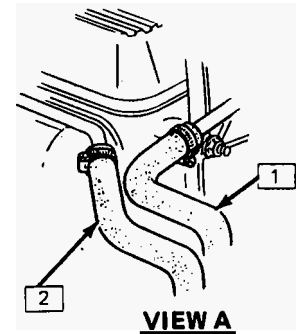

- 1 HOSE-HTR OUTLET
- 2 HOSE-HTR INLET
- 3 CLAMPASM

G40026-1 A-CEH

Figure 1A-25 Heater Hoses-C-E-H Series

ENG. CODE M(LT3)

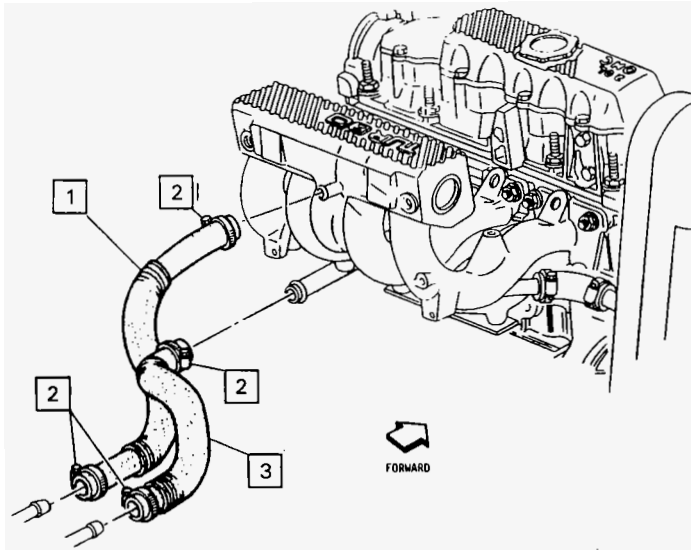

- 1 HOSE ASM-OUTLET
- 2 CLAMP ASM  
HOSE-INLET

ENG. CODE K(LT2)

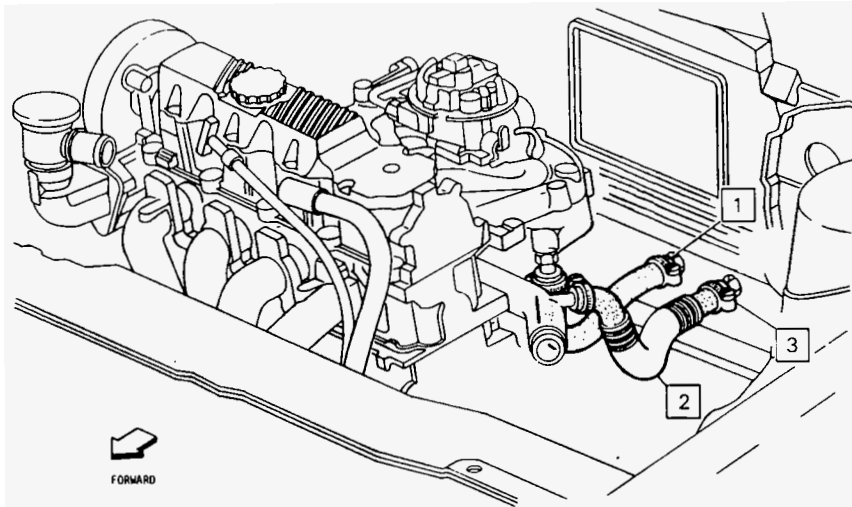

- HOSE INLET
- HOSE ASM-OUTLET
- 3 CLAMP

ENG. CODE 1(LL8)

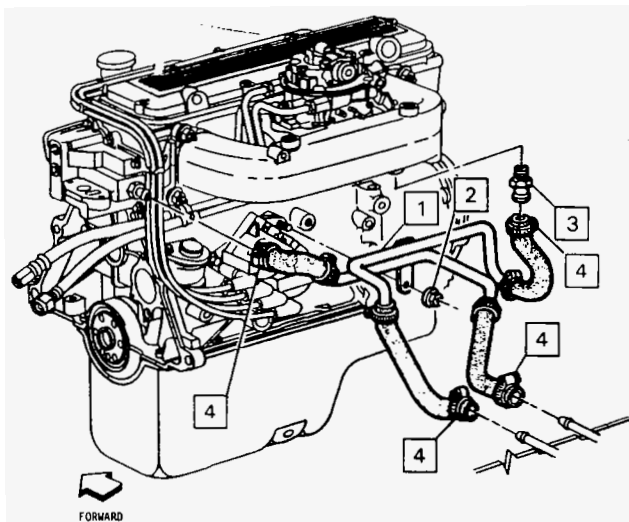

- 1 PIPE ASM
- NUT
- 3 FITTING ASM
- 4 CLAMP ASM

741A-26

Figure 1A-26 Heater Hoses-J Series

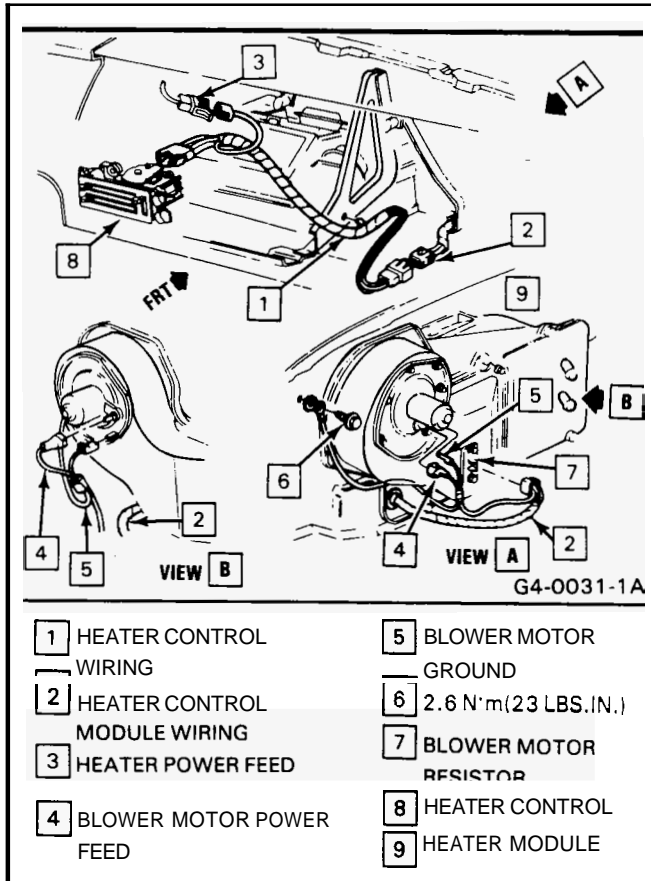

Figure 1A-27 A Series Heater Module & Control Wiring

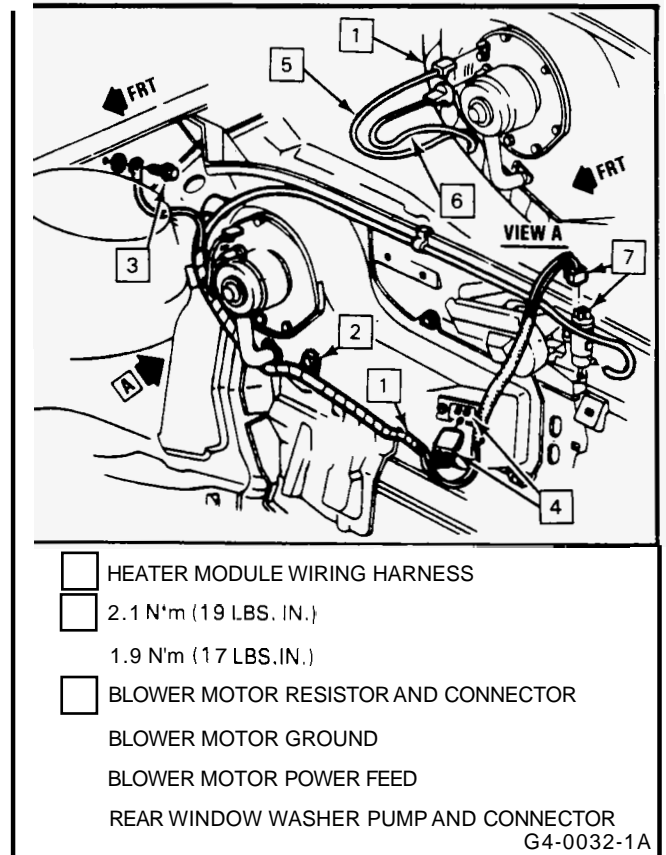

Figure 1A-28 J Series Heater Module & Control Wiring

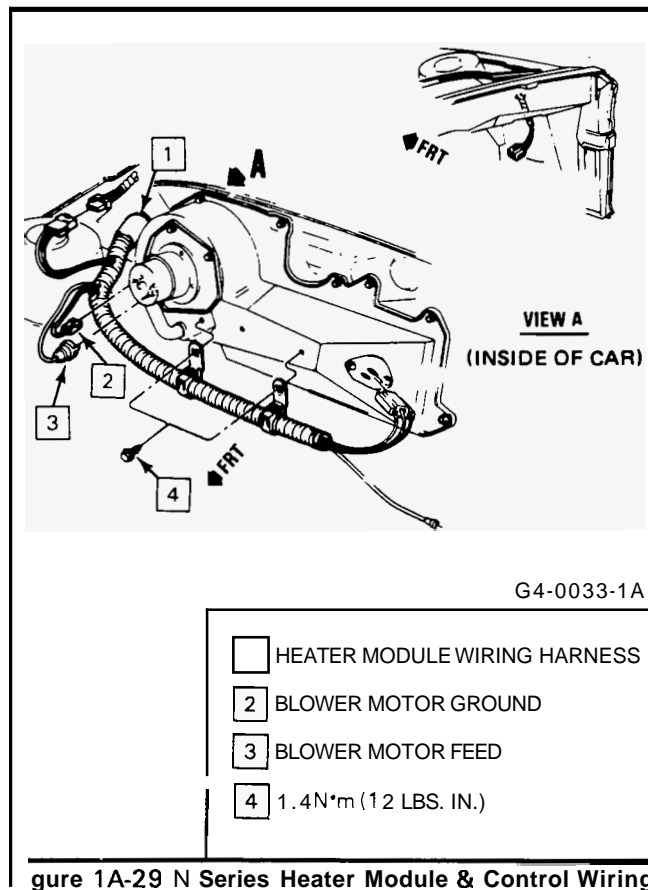

Figure 1A-29 N Series Heater Module & Control Wiring

